

This drawing is provisional and subject to our reconfirmation and/or revision without notice.

F E D C B A

DH1~DH2=25816 (±20)

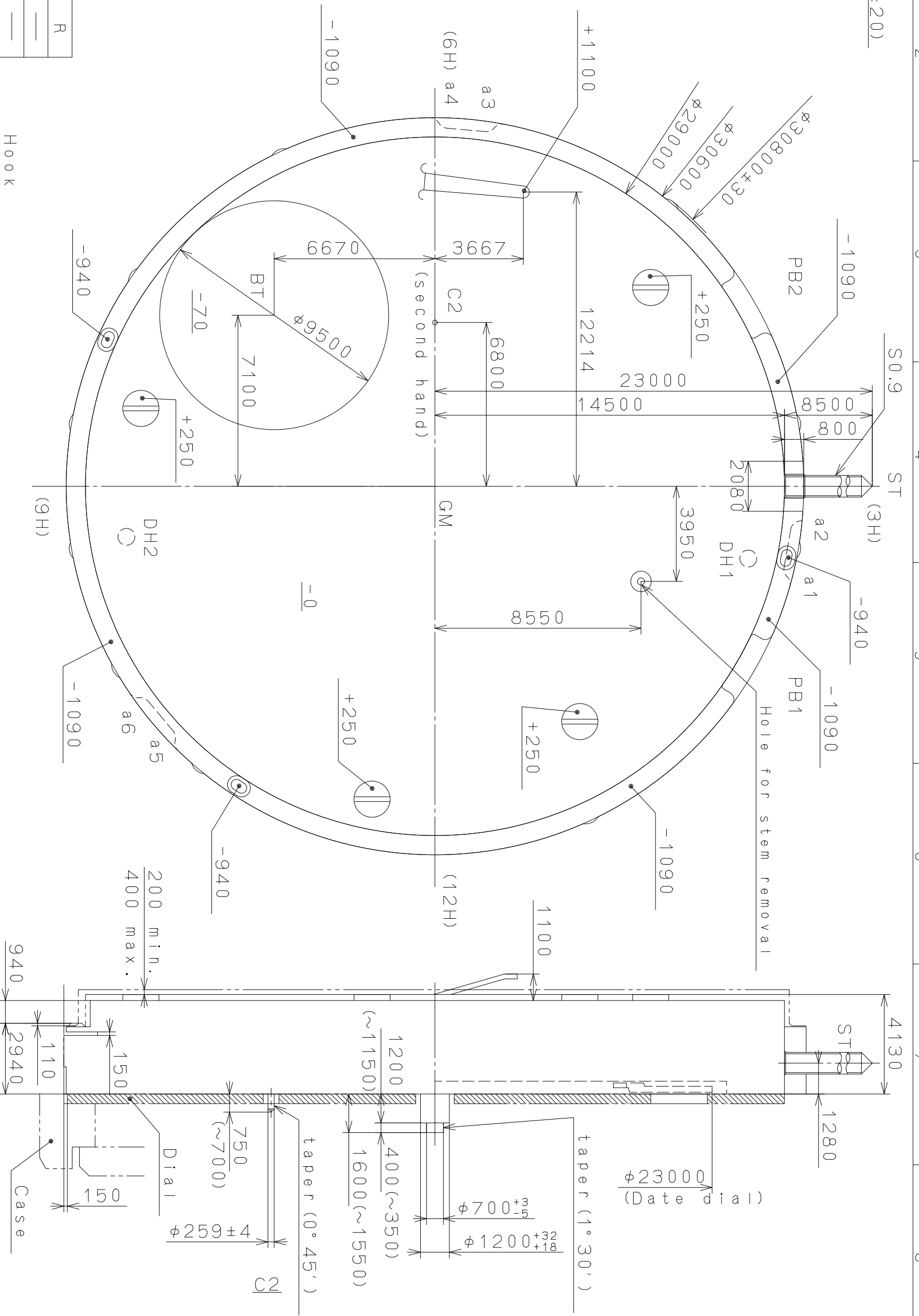

Coordinates

Mark	X	Y	R
GM	0	0	—
DH1	3000	13000	—
DH2	2100	-12800	—
a1	3441	14908	430
a2	1865	15186	430
a3	-15151	2129	430
a4	-15291	535	430
a5	10434	-11190	430
a6	9208	-12219	430

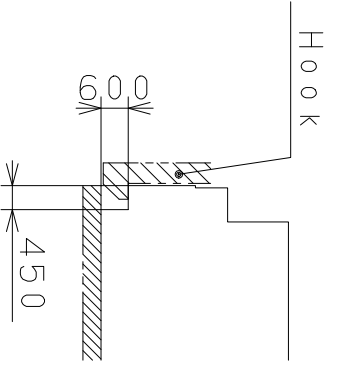

Material	Alterations	Date	Description	Appr.	Checked	M. Kobayashi	Name:	Frame for Case
Heat Treatment								Drawing No.: 0T45C000
Hardness								
Plating								
Quantity	Unit	Scale	6 : 1	Parts No.:	OT45	Cal. NO.:	OT45	
General Tolerances	Dimensions	Angles						

MIYOTA
CITIZEN WATCH CO., LTD. TOKYO, JAPAN

This drawing is provisional and subject to our reconfirmation and/or revision without notice.

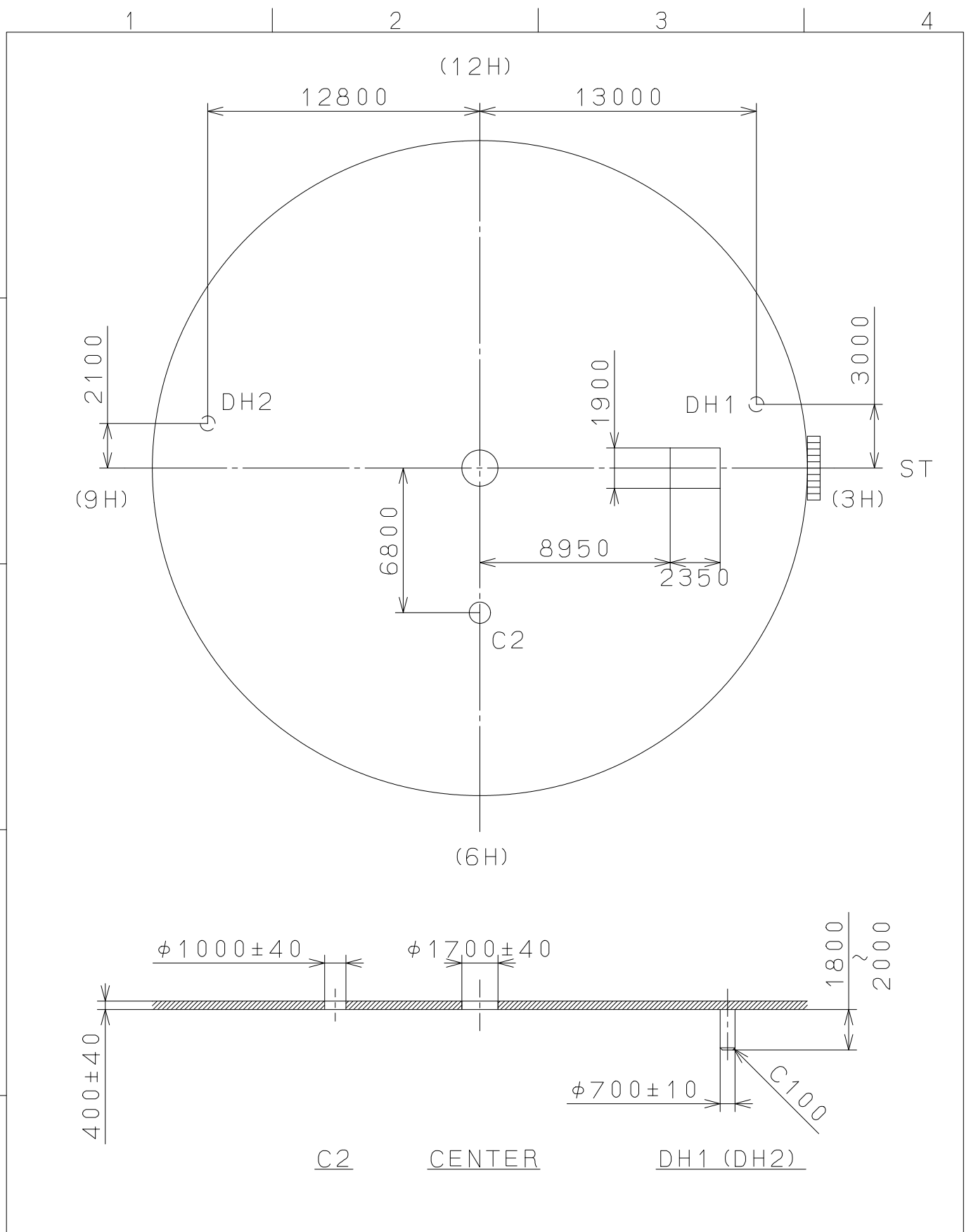

△			Quantity		Cal.NO.:
△			Unit	1 / 1000 mm	OT45-00A
△			Scale	4 : 1	Parts No.:
△			Date		
△			Drawn		
Mark	Date	Description	Appr.	Checked	M. Kobayashi
Alterations			Approved	Name:	
Material					Indications for Dial
Heat Treatment					Drawing No.: OT45D000
Hardness					MIYOTA
Plating					

This drawing is provisional and subject to our reconfirmation and/or revision without notice.

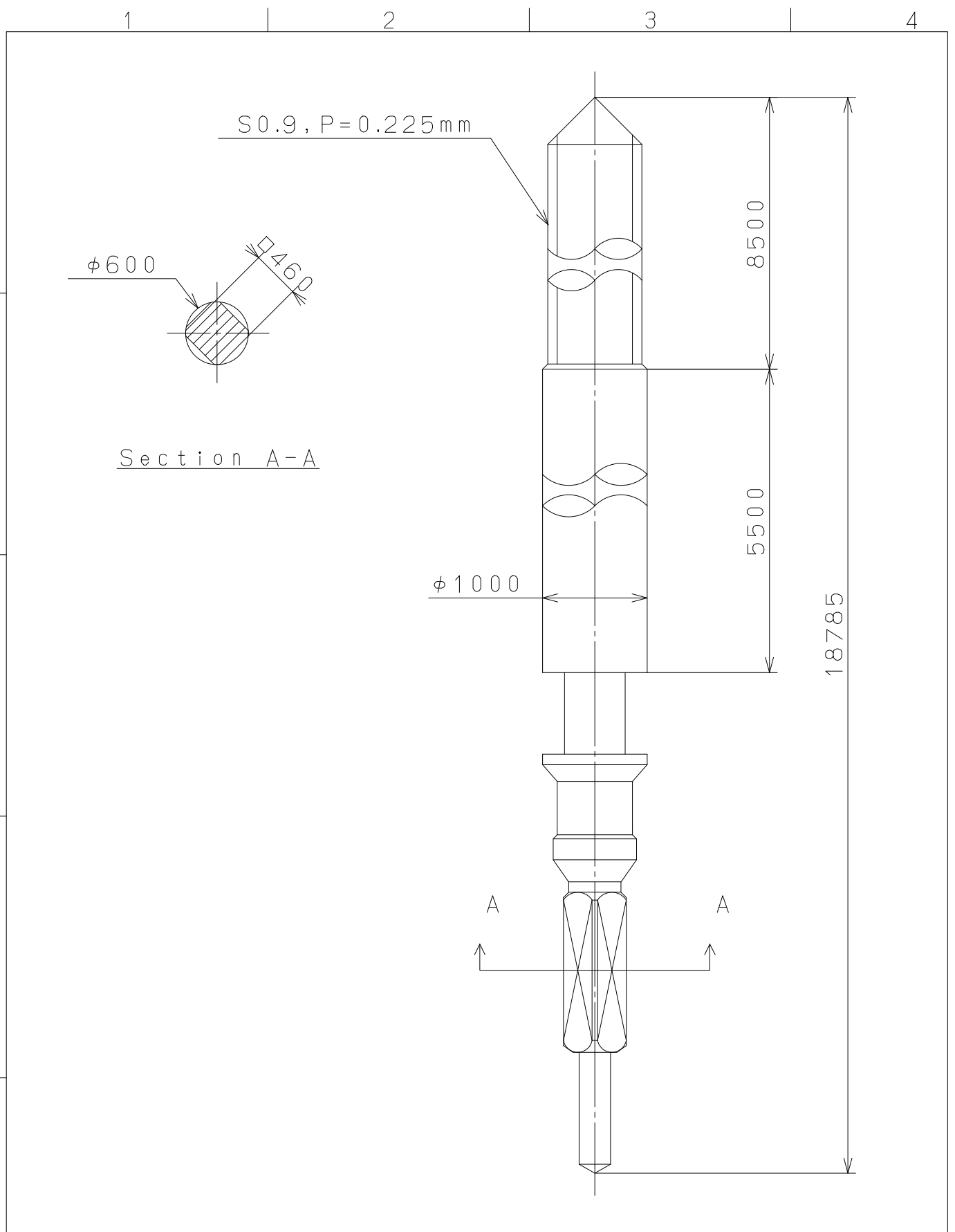

△5			Quantity		Cal.NO.:
△4			Unit	1 / 1000 mm	
△3			Scale	20 : 1	Parts No.:
△2			Date		065-453
△1			Drawn		
Mark	Date	Description	Appr.	Checked	E. Murakami
Alterations			Approved	Name:	
			SETTING STEM		
Material					Drawing No.: 4530S000
Heat Treatment					MIYOTA
Hardness					
Plating					
					CITIZEN WATCH CO., LTD. TOKYO, JAPAN