

Coordinates

Mark	X	Y	R
GM	0	0	
DH1	-7900	-3000	
DH2	8234	-1900	
a1	2553	7950	200
a2	7059	5000	500

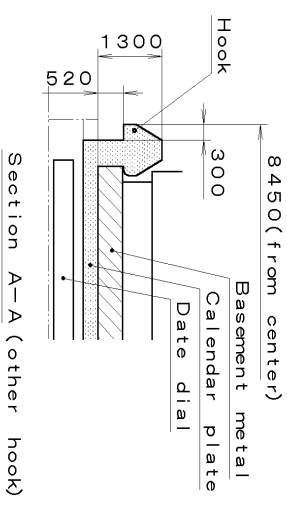

Quantity	1/1000 mm	Call. No. : 2015
Unit		Parts:
Scale	10:1	
Date		
Drawn		
Checked	T. Hiruta	Name :
Approved		Drawing No. : 20150000
Material		
Heat Treatment		
Hardness		
Plating		
General Tolerances		
Dimensions		
Angles		

This drawing is provisional and subject to our reconfirmation and/or revision without notice.

\*\*\* TIPW 2015-00A (01) \*\*\* (2100 1121) 00-08-14

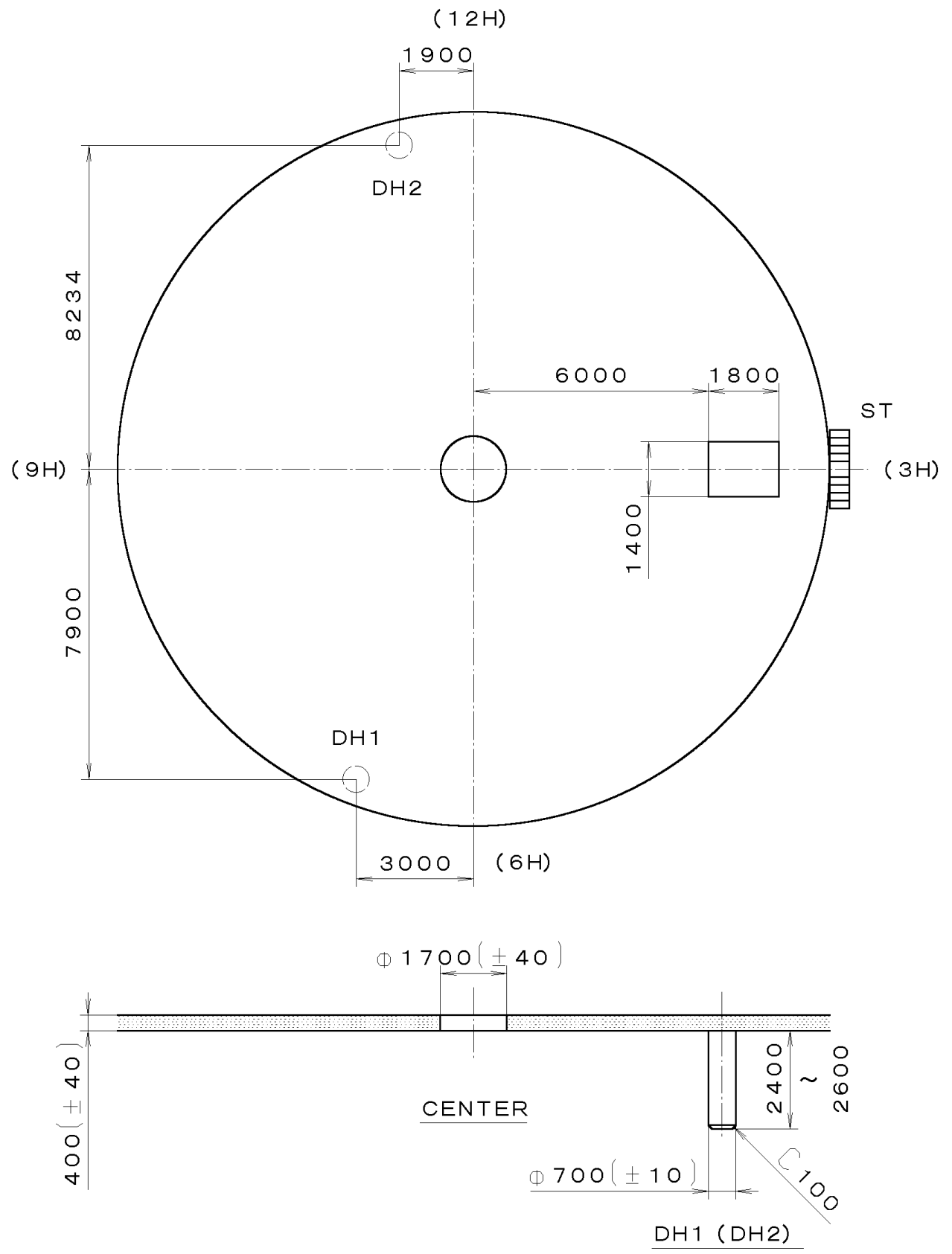

7			Quantity		Cal. No. : 2015-00A
6			Unit	1/1000 mm	
5			Scale	7:1	Parts:
4			Date		
3			Drawn		
2			Checked	T. Hiruta	Name:
1			Approved		Indications for Dial
Material					Drawing No. : 2015D000
Heat Treatment			General Tolerances		
Hardness			Dimensions		
Plating			Angles		

This drawing is provisional and subject to our reconfirmation and/or revision without notice.

\*\*\* T I P W (01) \*\*\* (2100 1121) 00-06-23

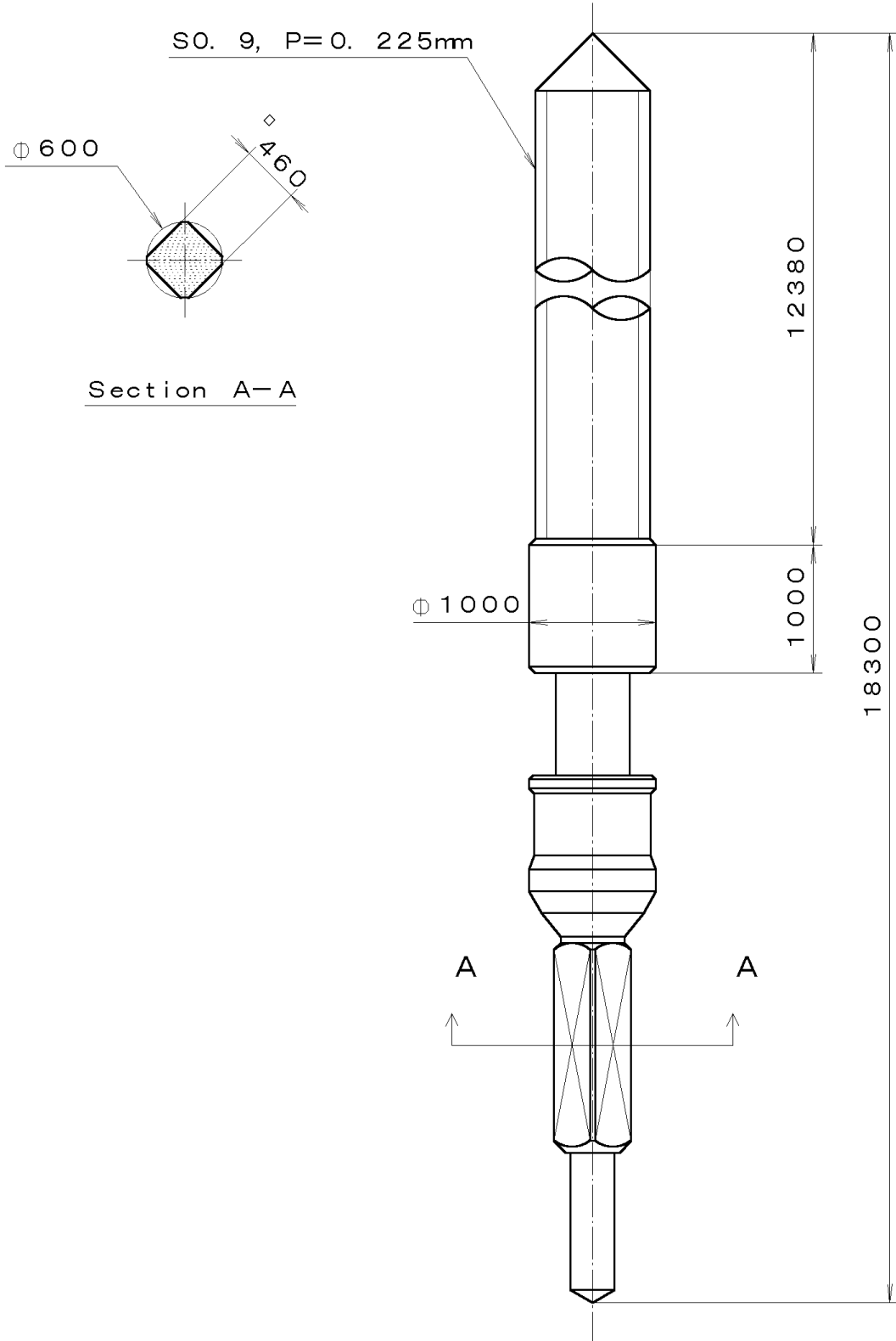

7		Quantity		Ca l. No. :
6		Unit	1/1000 mm	Parts:
5		Scale	20:1	
4		Date		065-299
3		Drawn		
2		Checked	T. Hiruta	Name:
1		Approved		SETTING STEM
Material				Drawing No. : 2990S000
Heat Treatment		General Tolerances		
Hardness		Dimensions		
Plating		Angles		