

2011/12/12 (14:22:37)

This drawing is provisional and subject to our reconfirmation and/or revision without notice.

DH1~DH2=32195 (±20)

Coordinates

記号	X	Y	R
GM	0	0	—
DH1	-15200	-5300	—
DH2	15200	5300	—
b1	3092	16654	320
b2	-16920	800	320
b3	-16920	-800	320
b4	-800	-16920	320
b5	800	-16920	320
b6	16920	-800	320
b7	16920	800	320

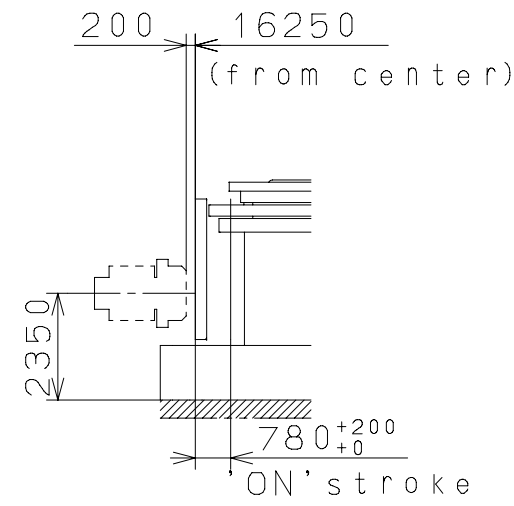
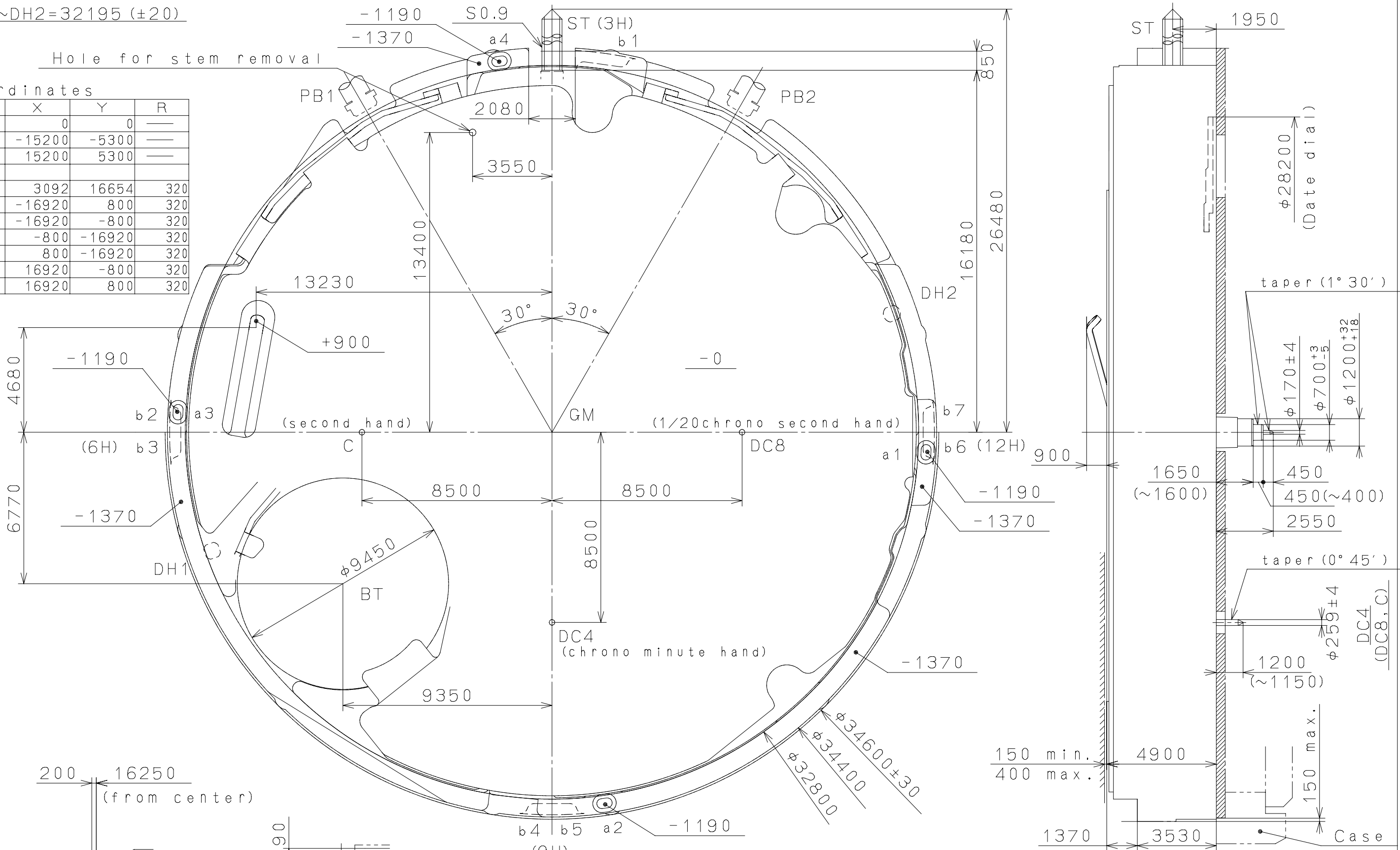

Section PB1 (PB2)

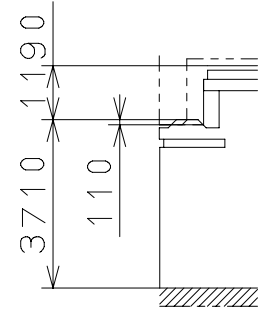

Section a1~4

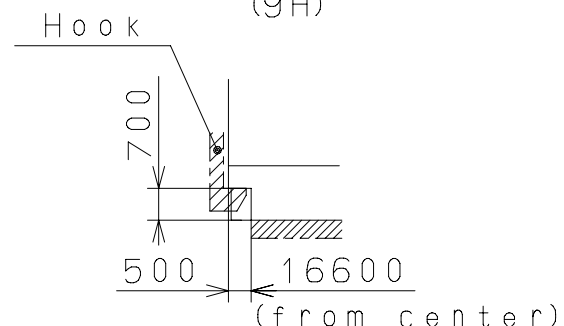

Section b1~7

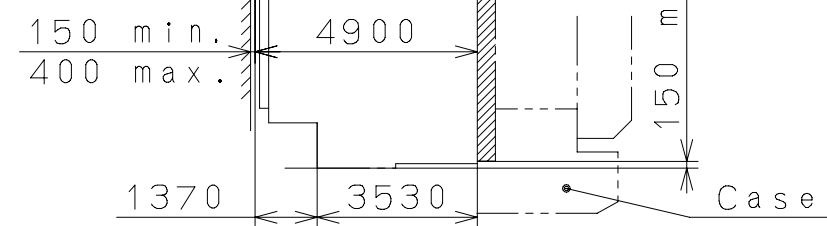

Quantity	Unit	Scale	Date	Drawn	Mark	Date	Description	Appr.	Checked	N. Suzuki	Name:	Cal. NO.:	6S10
	1/1000mm	6:1									Frame for Case	Parts No.:	
Alterations										Approved	Drawing No.: 6S10C001		
Material	General Tolerances												
Heat Treatment	Dimensions												
Hardness	Angles												
Plating	CITIZEN WATCH CO., LTD. TOKYO, JAPAN												

2010/05/24 (09:02:40)

This drawing is provisional and subject to our reconfirmation and/or revision without notice.

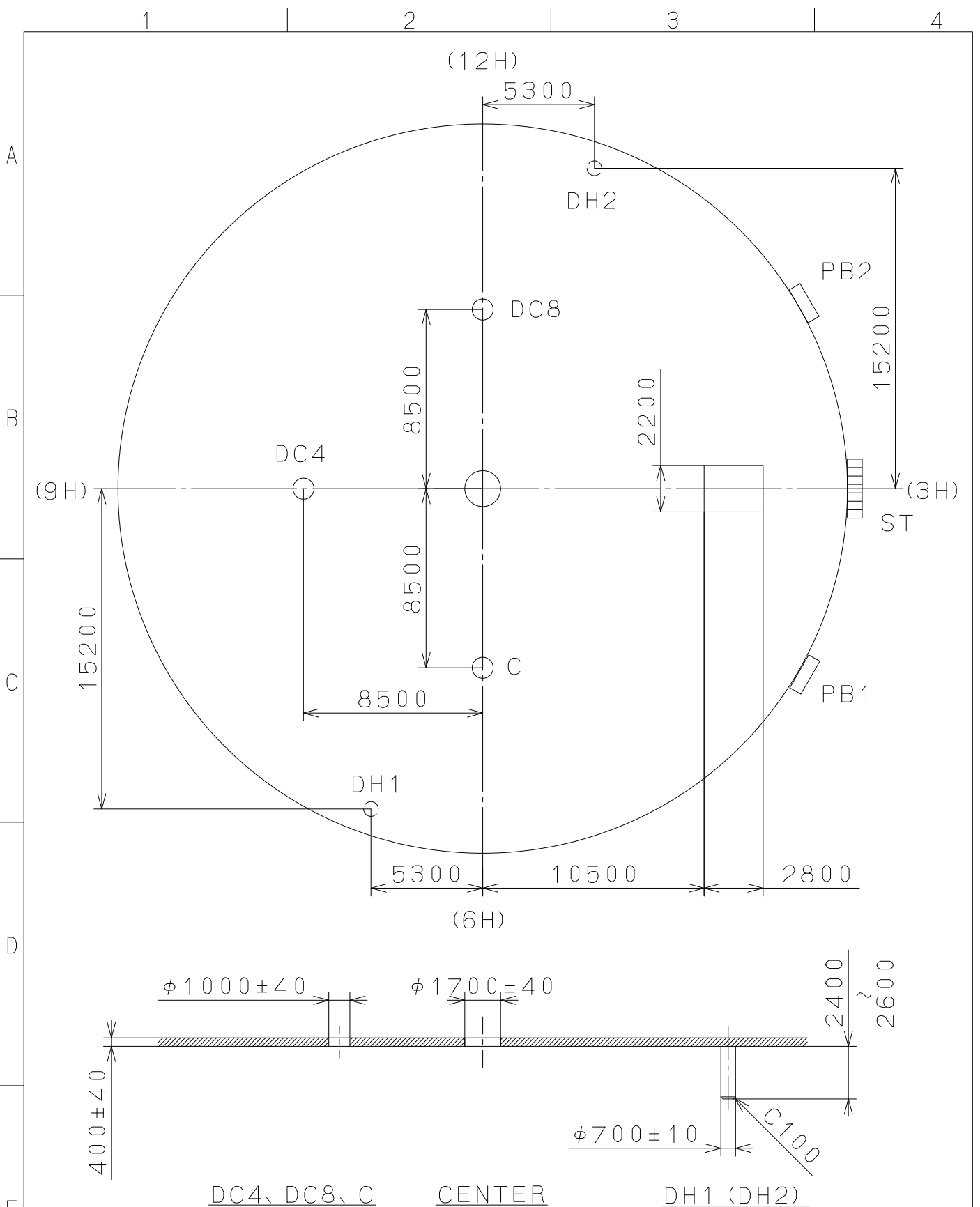

△			Quantity		Cal.NO.:
△			Unit	1/1000mm	6S10-00A
△			Scale	4:1	Parts No.:
△			Date		
△			Drawn		
Mark	Date	Description	Appr.	Checked	Name:
		Alterations	Approved	N. Suzuki	Indications for Dial
Material					Drawing No.: 6S10D000
Heat Treatment			General Tolerances		
Hardness			Dimensions		
Plating			Angles		
				CITIZEN WATCH CO., LTD. TOKYO, JAPAN	

2010/07/26 (09:03:08)

This drawing is provisional and subject to our reconfirmation and/or revision without notice.

A
B
C
D
E
F

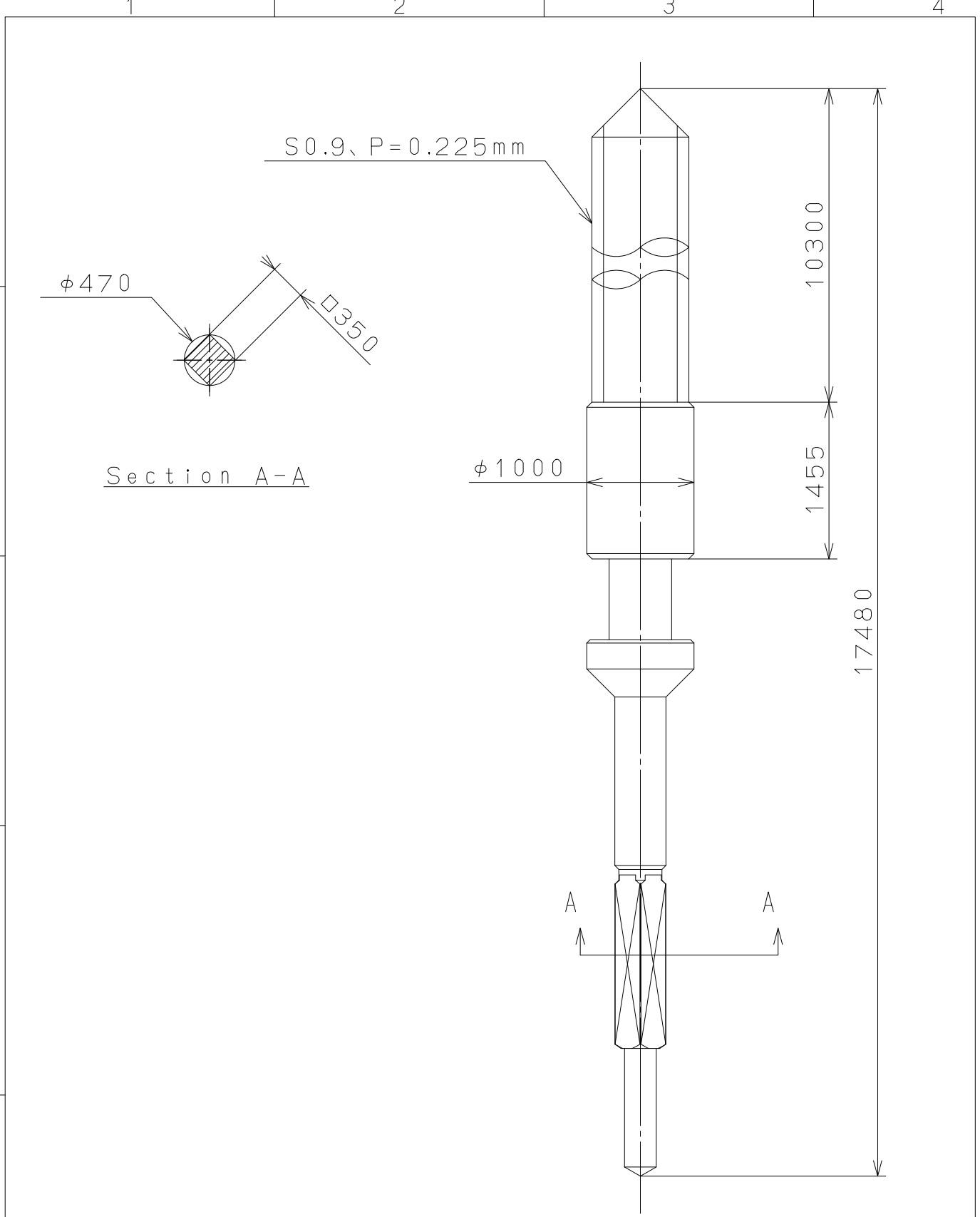

△5			Quantity		Cal.NO.:
△4			Unit	1/1000mm	
△3			Scale	20:1	Parts No.:
△2			Date		065-A13
△1			Drawn		
Mark	Date	Description	Appr.	Checked	Name:
		Alterations	Approved	N. Suzuki	SETTING STEM
Material					Drawing No.: A130S000
Heat Treatment			General Tolerances		
Hardness			Dimensions		
Plating			Angles		
				CITIZEN WATCH CO., LTD. TOKYO, JAPAN	