

This drawing is provisional and subject to our reconfirmation and/or revision without notice.

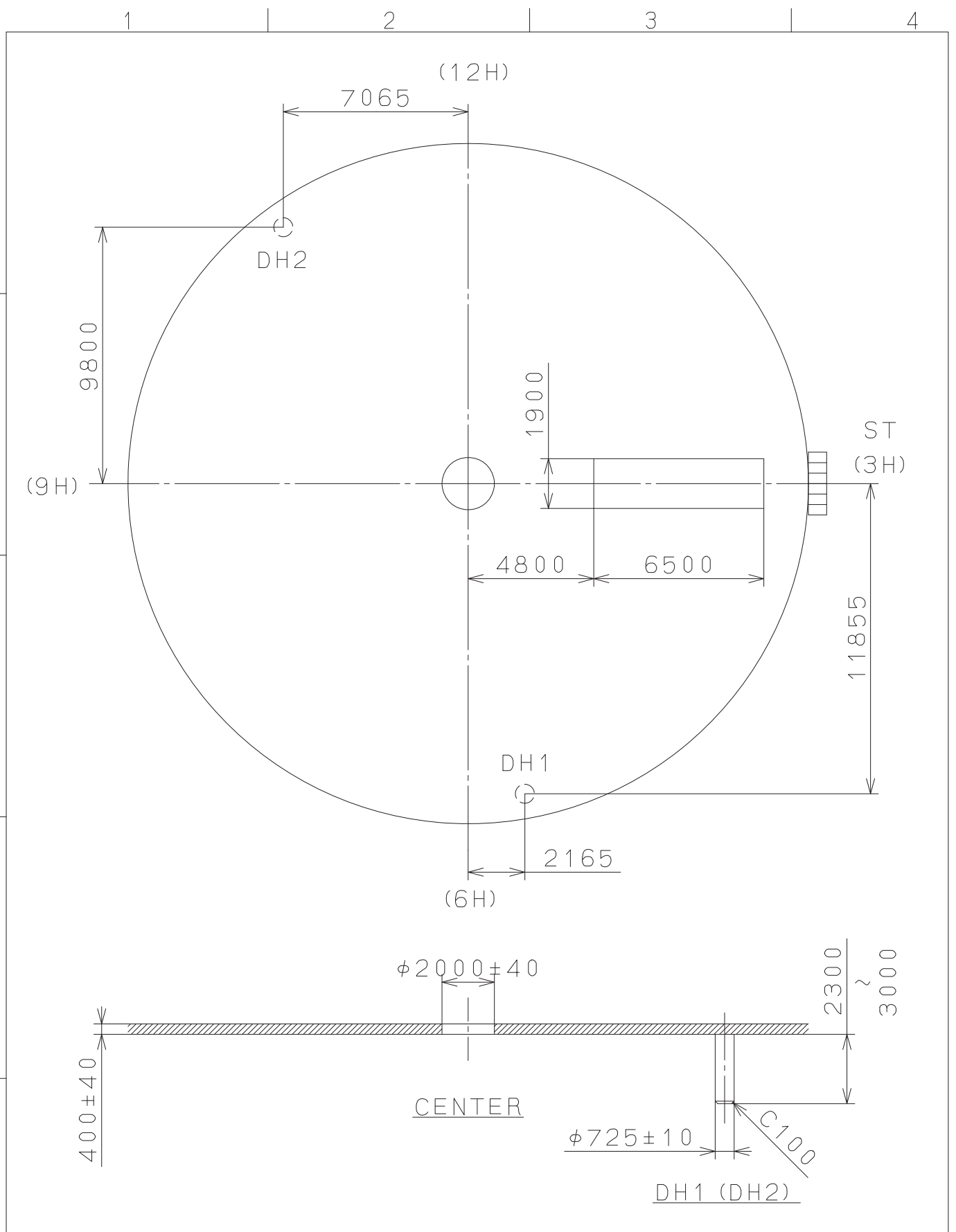

△			Quantity		Cal.NO.:
△			Unit	1 / 1000 mm	820A-21C
△			Scale	5 : 1	Parts No.:
△			Date		
△			Drawn		
Mark	Date	Description	Appr.	Checked	E. Murakami
Alterations			Approved	Name:	
Material					Indications for Dial
Heat Treatment					Drawing No.: 820AD000
Hardness					MIYOTA
Plating					

This drawing is provisional and subject to our reconfirmation and/or revision without notice.

xxx T I P W (01) xxx (2100 1121) 00-09-18 065-212

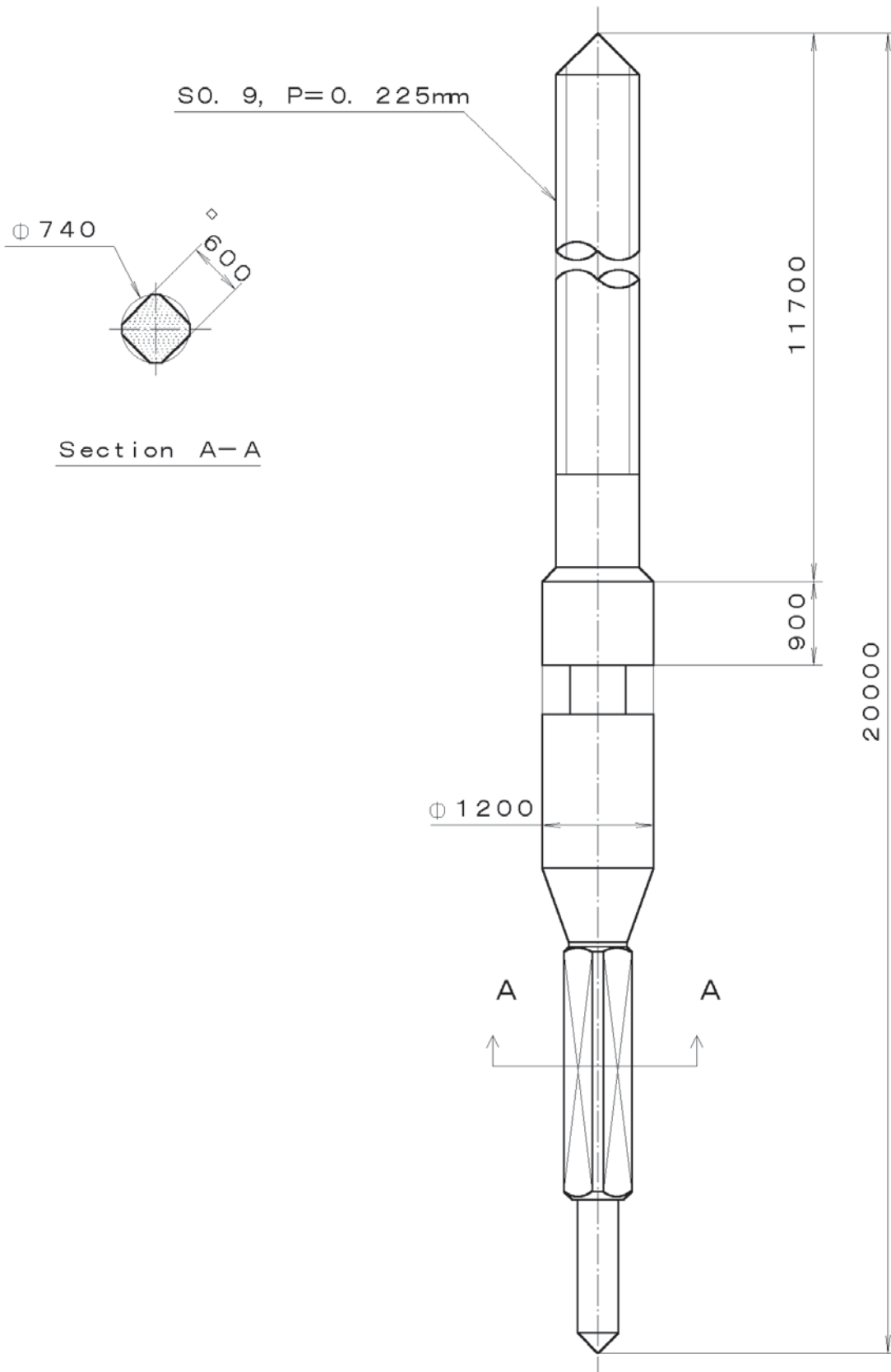

7		Quantity		Cal. No. :
6		Unit	1/1000 mm	Parts:
5		Scale	15:1	
4		Date		065-212
3		Drawn		
2		Checked	T. Hiruta	Name :
1		Approved		SETTING STEM
Material				Drawing No. : 2120S000
Heat Treatment		General Tolerances		MIYOTA
Hardness		Dimensions		
Plating		Angles		

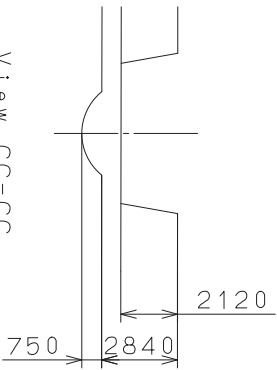
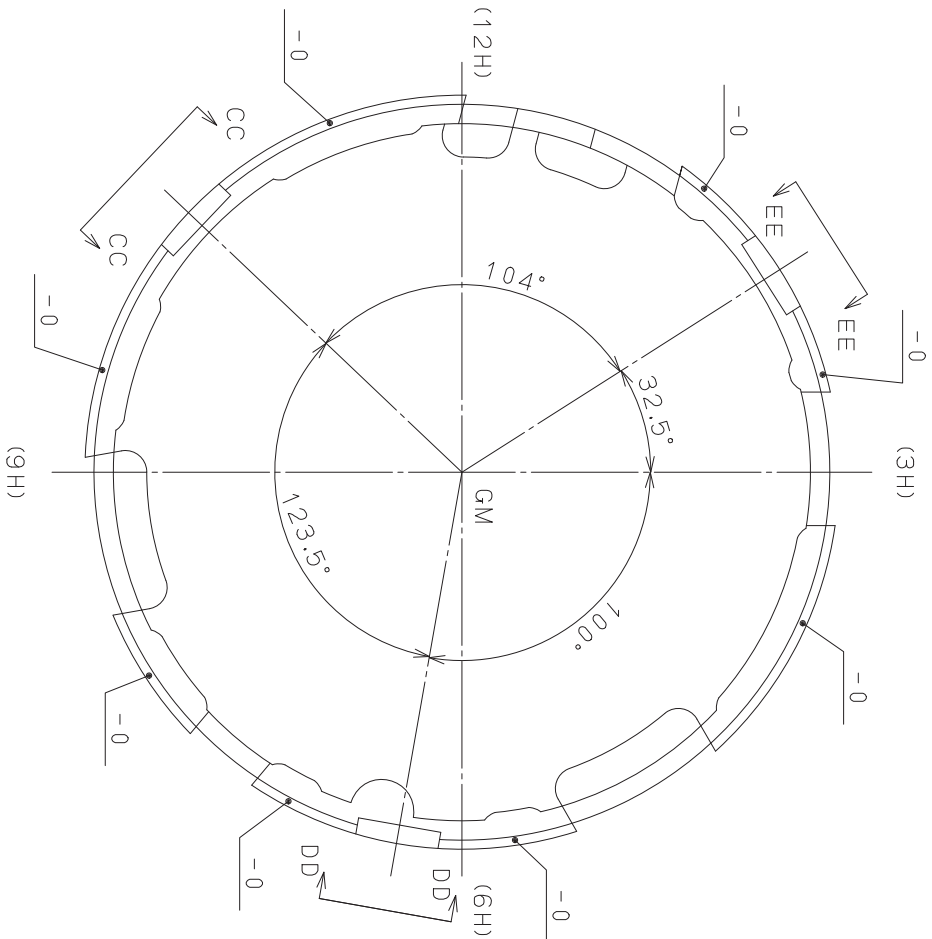
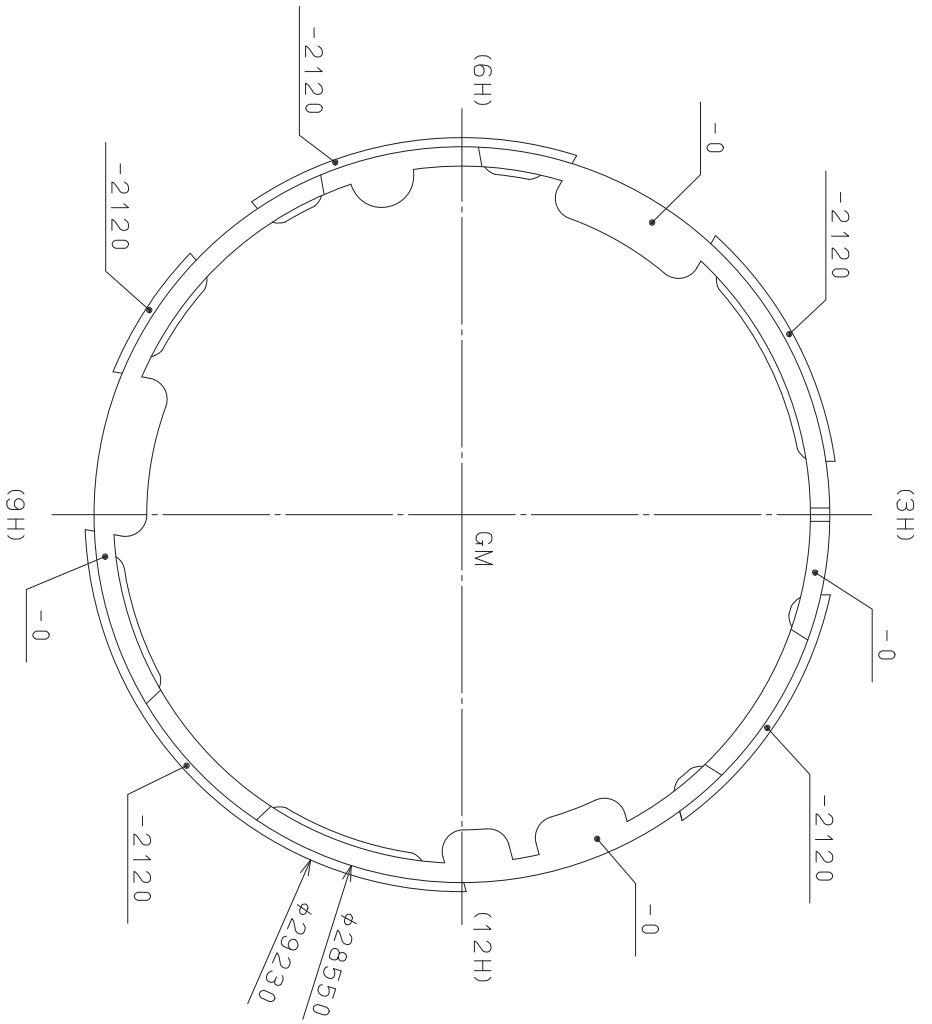

View CC-CC
DD-DD, EE-EE

△	Quantity	1/1000 mm	Cal. No.:
△	Unit	5 : 1	Parts No.:
△	Scale	500-710	
△	Date		
△	Date		
△	Drawn		
Mark	Date	Appr.	Checked
Alterations	N. Suzuki		
Material	Casing Holder		
Heat Treatment	Drawing No.: 8200E002		
Hardness	General Tolerances		
Plating	Dimensions		
	Angles		
	CITIZEN WATCH CO., LTD. TOKYO, JAPAN		
	MIYOTA		