

This drawing is provisional and subject to our reconfirmation and/or revision without notice.

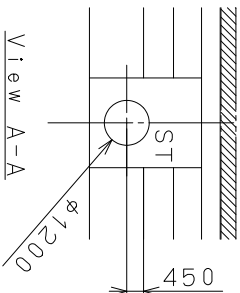
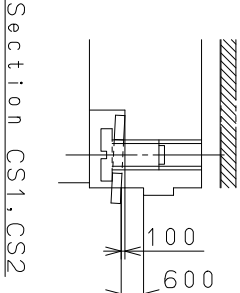
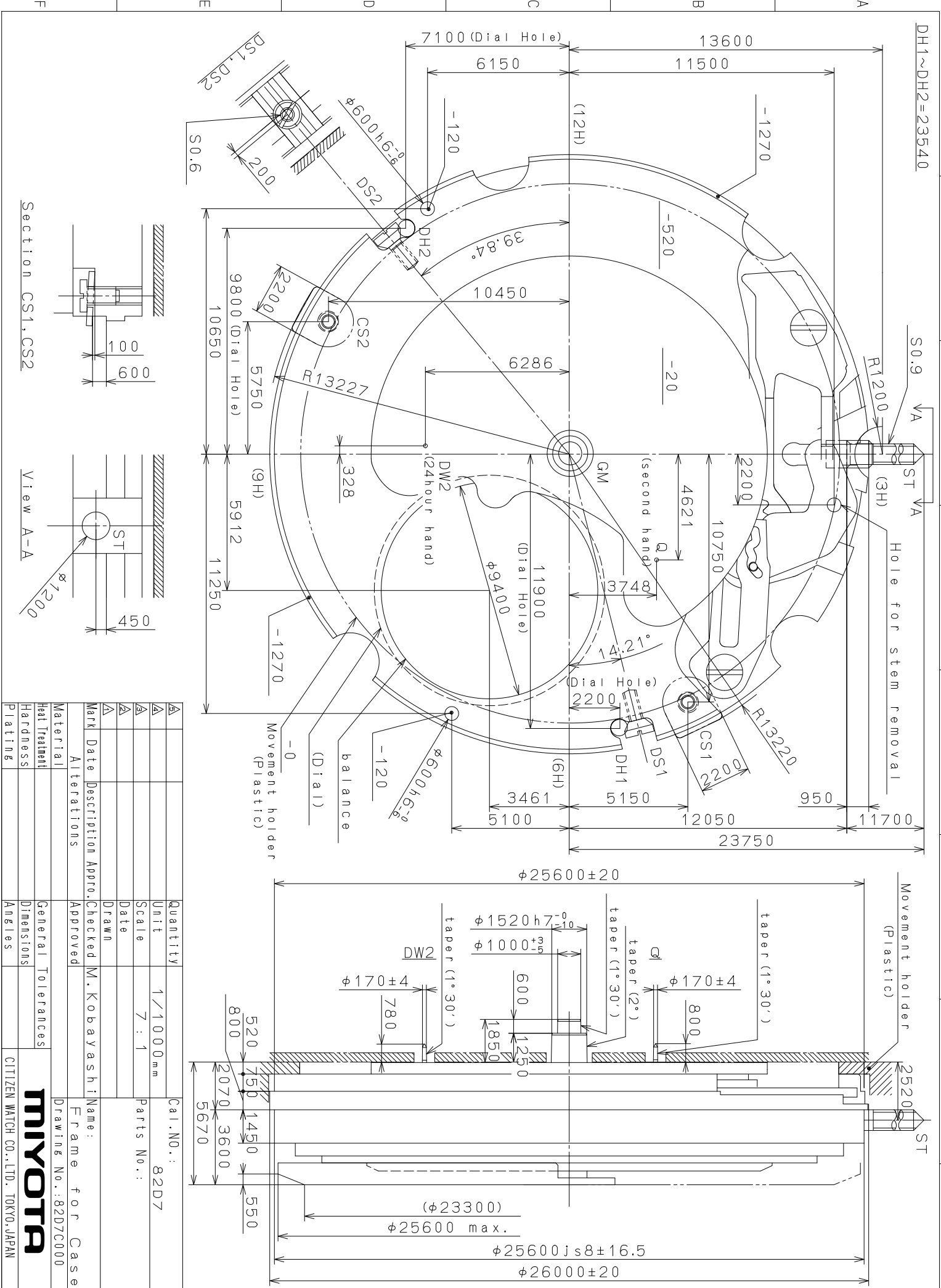

Material	Alterations	Mark Date	Description	Appr.	Checked	M. Kobayashi	Name:	Frame for Case
Heat Treatment								Drawing No.: 82D7C000
Hardness								
Plating								
Quantity	Unit	1/1000	mm	Cal. No.:	82D7			
Scale	7 : 1							
Date	Parts No.:							
Drawn								
Checked								
Approved								
General Tolerances								
Dimensions								
Angles								

**MIYOTA**  
CITIZEN WATCH CO., LTD. TOKYO, JAPAN

This drawing is provisional and subject to our reconfirmation and/or revision without notice.

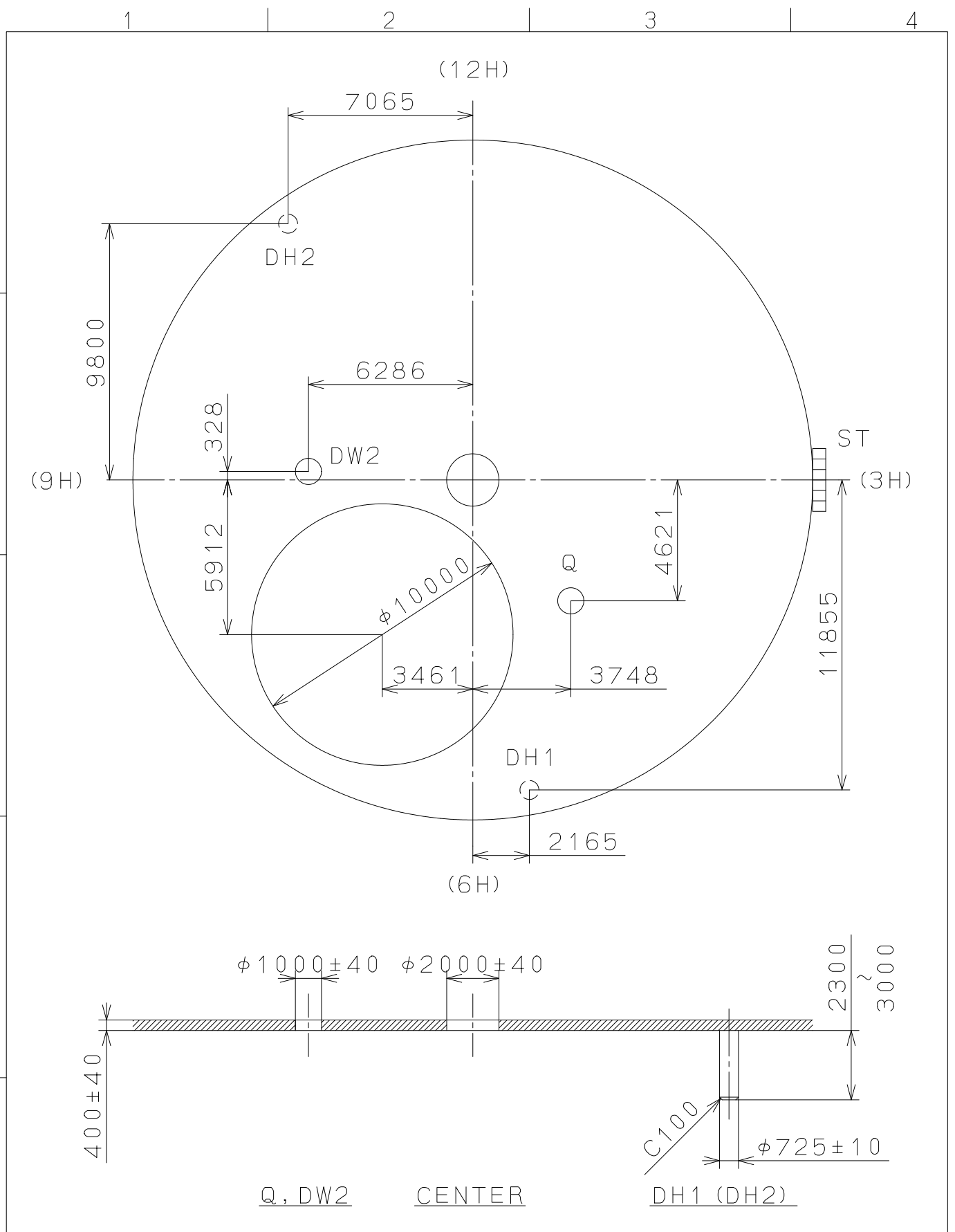

△			Quantity		Cal.NO.: 82D7-43A
△			Unit	1 / 1000 mm	82D7-43G
△			Scale	5 : 1	Parts No.:
△			Date		
△			Drawn		
Mark	Date	Description	Appr.	Checked	M. Kobayashi
Alterations			Approved	Name:	
Material					Indications for Dial
Heat Treatment					Drawing No.: 82D7D000
Hardness					<b>MIYOTA</b>
Plating					
					CITIZEN WATCH CO., LTD. TOKYO, JAPAN

2008/11/14 (11:30:42)

This drawing is provisional and subject to our reconfirmation and/or revision without notice.

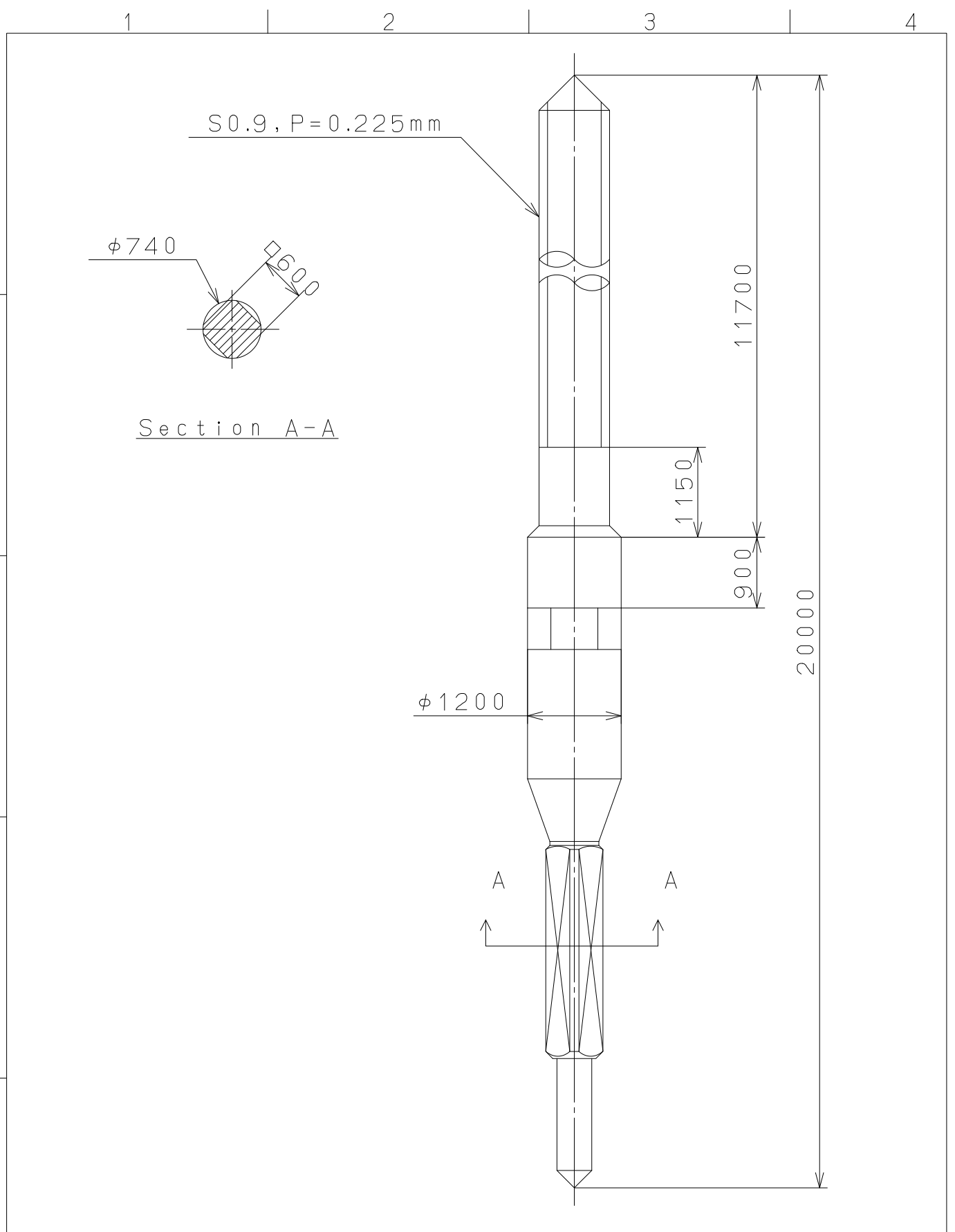

⑤			Quantity		Cal.NO.:
④			Unit	1/1000mm	
③			Scale	15:1	Parts No.:
②			Date		065-212
①			Drawn		Name:
Mark	Date	Description	Appr.	Checked	N. Suzuki
Alterations			Approved	SETTING STEM	
Material					Drawing No.:2120S001
Heat Treatment	General Tolerances				<b>MIYOTA</b>
Hardness	Dimensions				
Plating	Angles				
					CITIZEN WATCH CO.,LTD. TOKYO,JAPAN

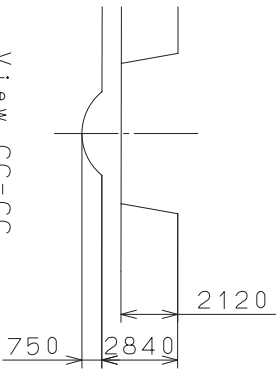
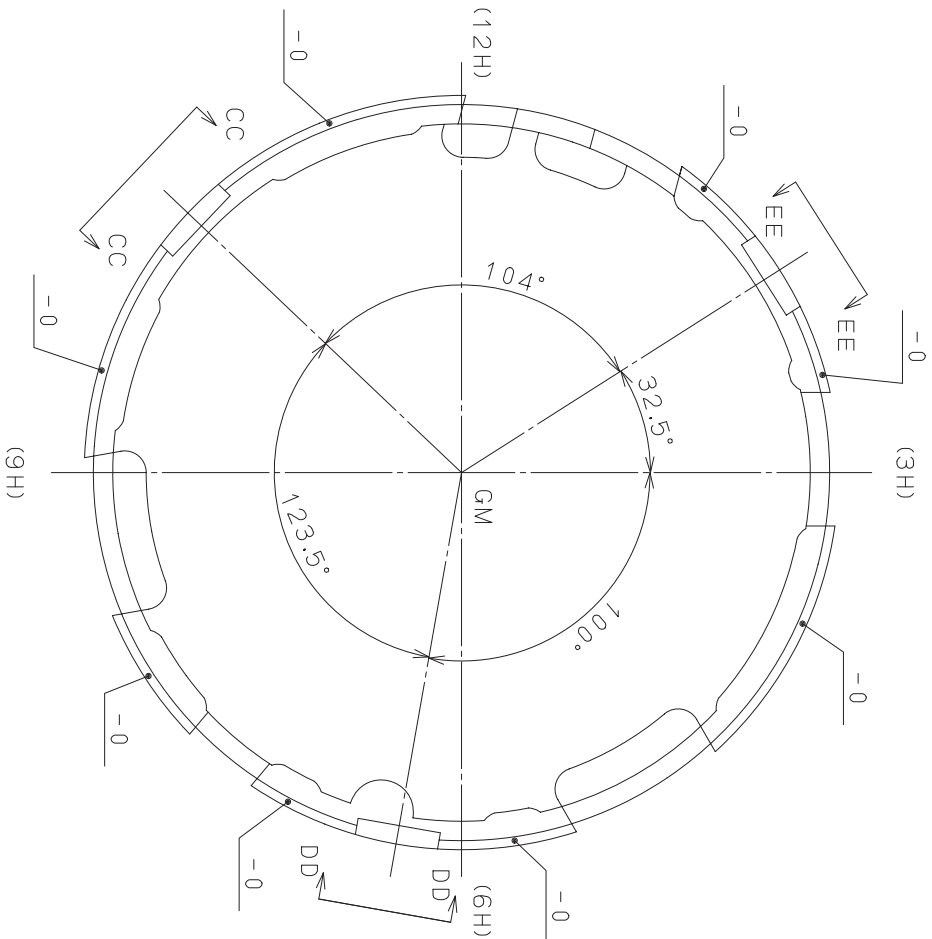
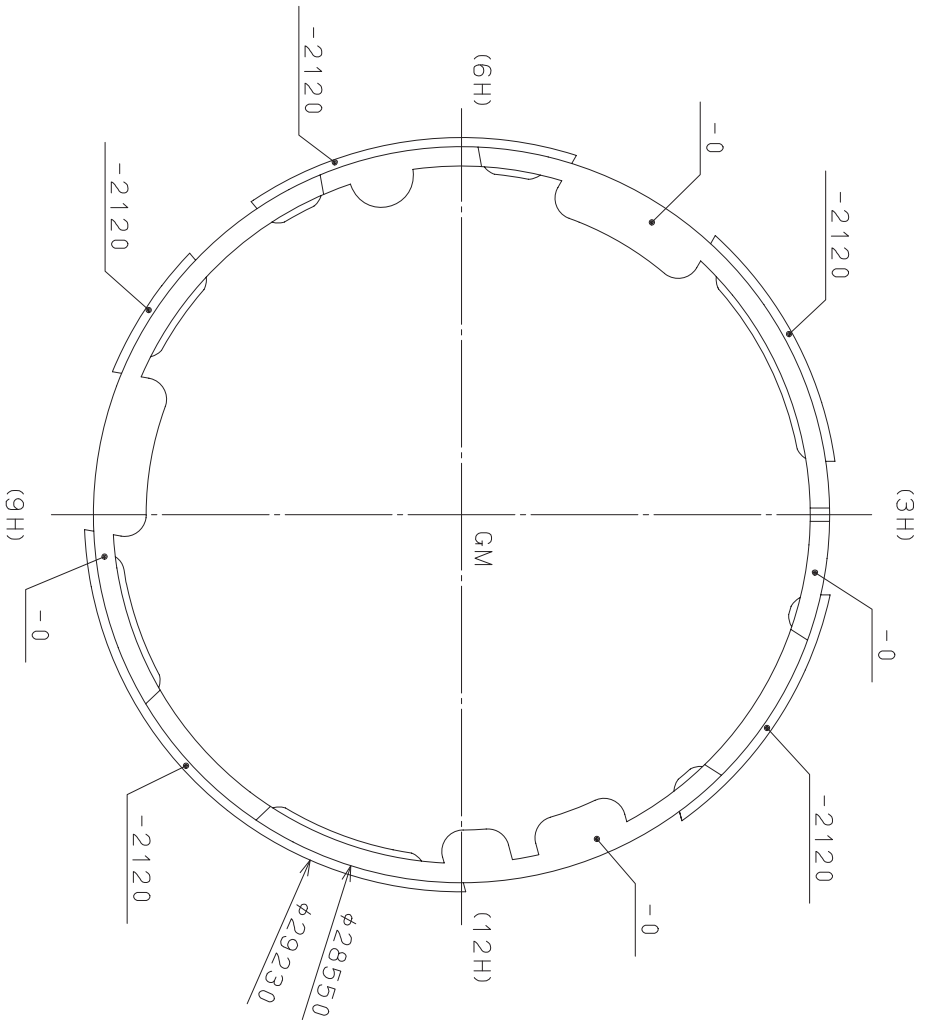

View CC-CC  
DD-DD, EE-EE

△	Quantity	1/1000 mm	Call. NO.:
△	Unit	5 : 1	Parts No.:
△	Scale	500-710	
△	Date		
△	Date		
△	Drawn		
Mark	Date	Checked	Name:
Alterations	Description	Approved	Casing Holder
Material	Alterations	Approved	Drawing No.: 8200E002
Heat Treatment	General Tolerances		
Hardness	Dimensions		
Plating	Angles		

**MIYOTA**

CITIZEN WATCH CO., LTD. TOKYO, JAPAN