

Section CS1, CS2

Section A-A

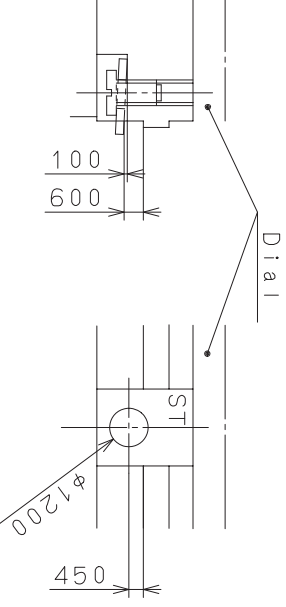

Material	Alterations	Quantity	Unit	Cal. NO.:
Heat Treatment		1/1000	mm	8N24
Hardness		Scale	6 : 1	Parts No.:
Plating		Date	Drawn	
	Mark Date	Description	Appr.	Checked
				N. Suzuki
	Material	General Tolerances	Name: Frame for Case	
		Dimensions	Drawing No.: 8N24C002	
		Angles	CITIZEN WATCH CO., LTD. TOKYO, JAPAN	

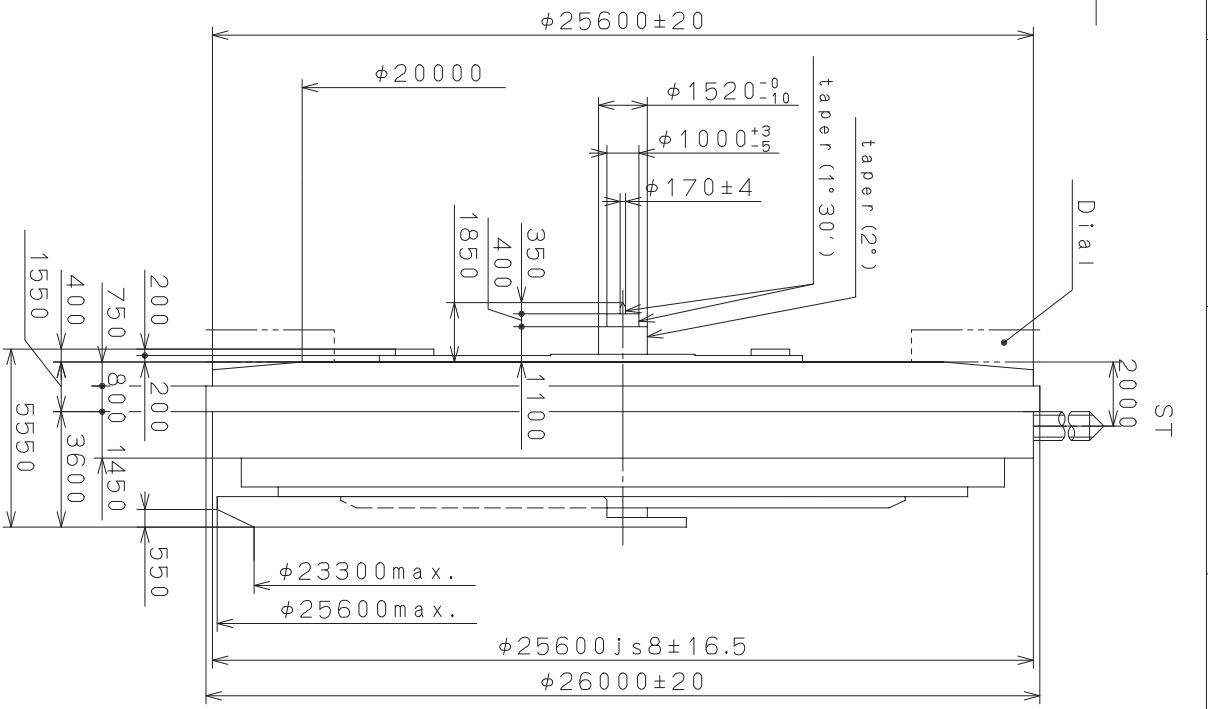

MIYOTA

2005/09/06 (08:11:39)

This drawing is provisional and subject to our reconfirmation and/or revision without notice.

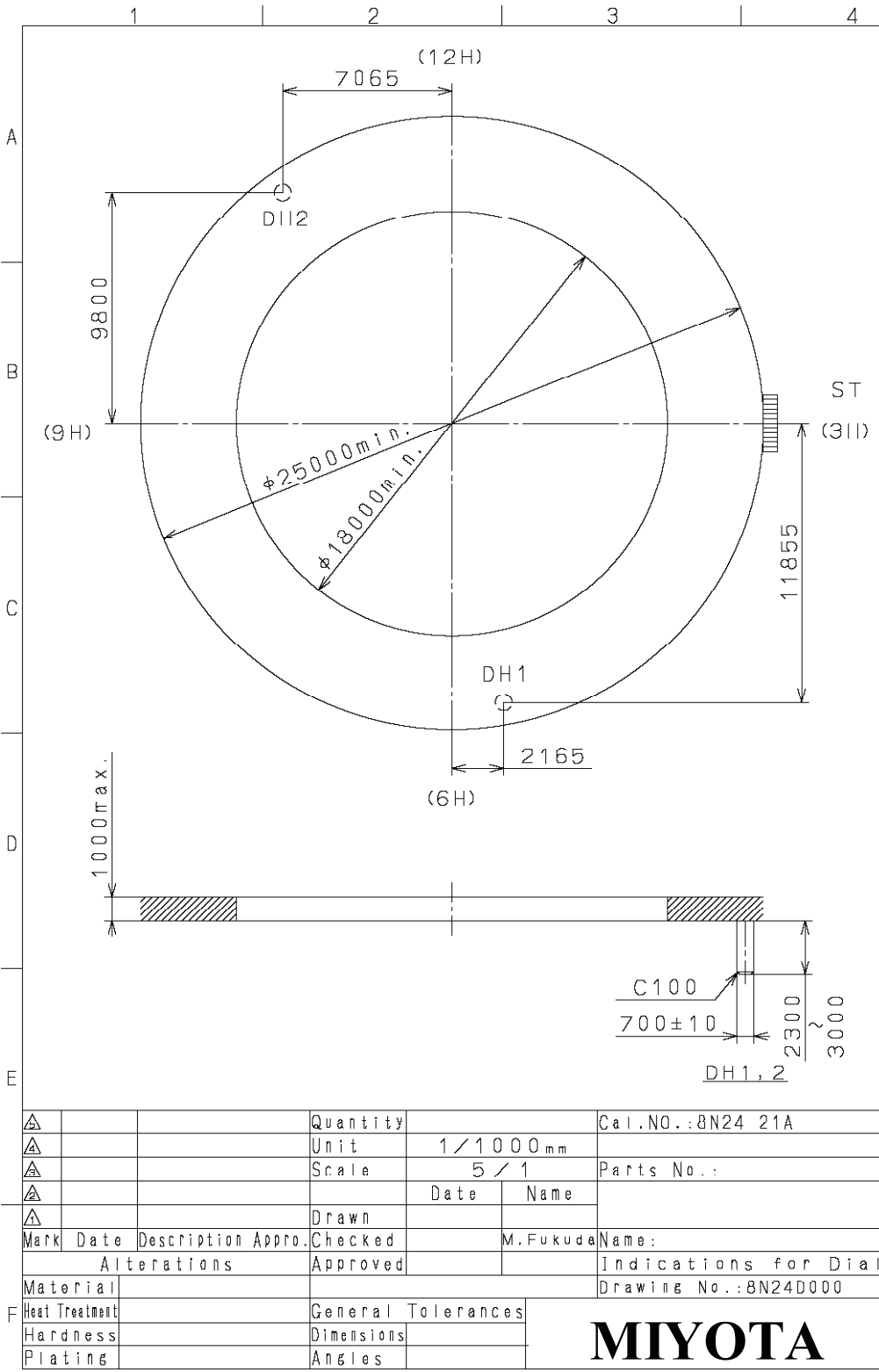

△				Quantity		Cal.NO.: 8N24 21A
△				Unit	1 / 1000 mm	
△				Scale	5 / 1	Parts No.:
△				Date	Name	
△				Drawn		
Mark	Date	Description	Appr.	Checked	M. Fukuda	Name:
		Alterations		Approved		Indications for Dial
Material						Drawing No.: 8N240000
Heat Treatment				General Tolerances		
Hardness				Dimensions		
Plating				Angles		

MIYOTA

This drawing is provisional and subject to our reconfirmation and/or revision without notice

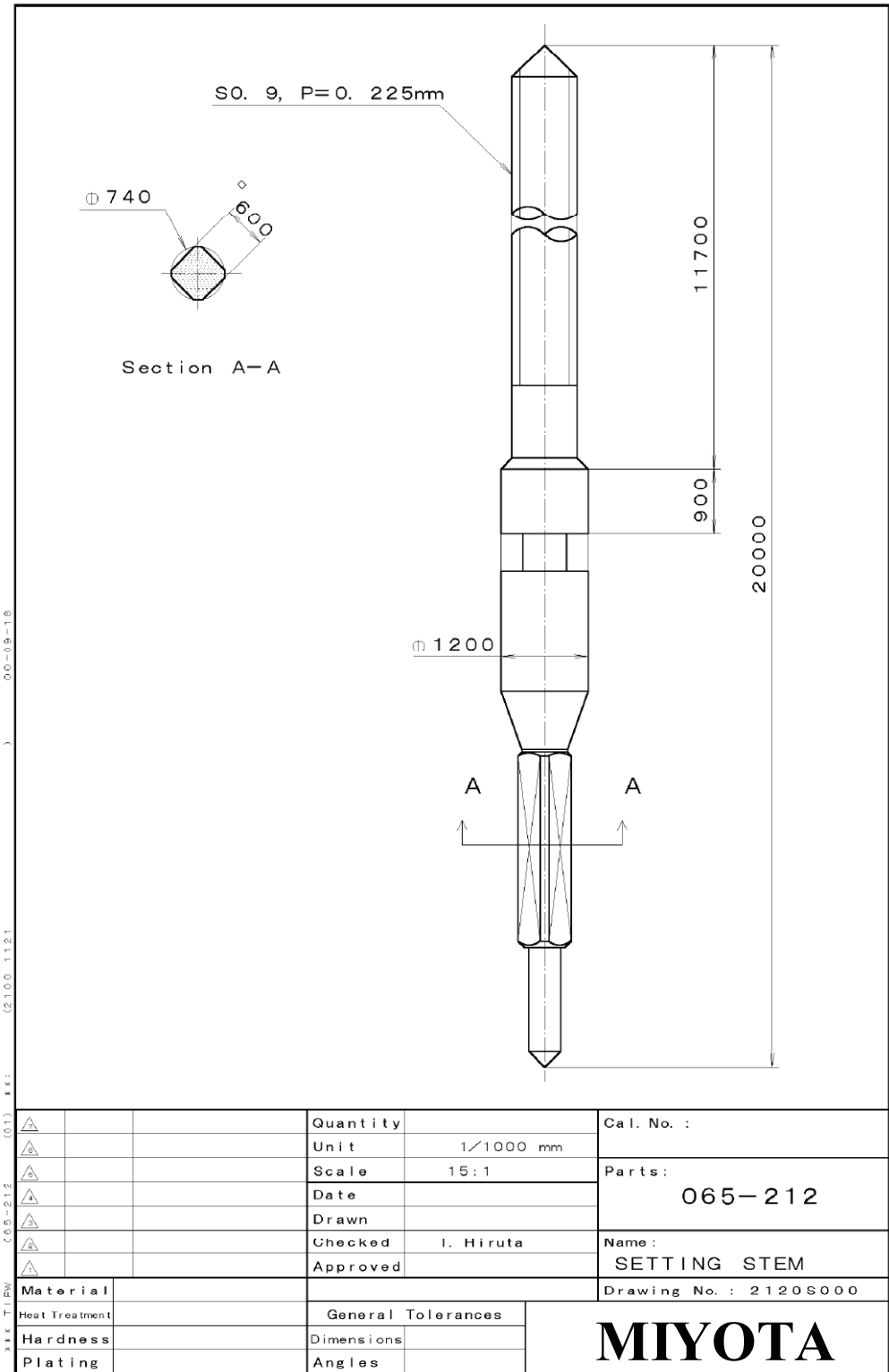

△			Quantity		Cal. No. :
△			Unit	1/1000 mm	
△			Scale	15:1	Parts:
△			Date		065-212
△			Drawn		Name:
△			Checked	I. Hiruta	SETTING STEM
△			Approved		Drawing No. : 2120S000
Material			General Tolerances		MIYOTA
Heat Treatment			Dimensions		
Hardness			Angles		
Plating					