

This drawing is provisional and subject to our reconfirmation and/or revision without notice.

DH1~DH2=20947 (±30)

Coordinates

記号	X	Y	R
GM	0	0	
DH1	-10813	-2722	
DH2	10022	-4886	
a1	8364	8889	1200
a2	-8455	8802	1200
a3	-8078	-10529	2000
a4	-7303	-11081	2000
a5	8494	-10197	2000
a6	9203	-9562	2000

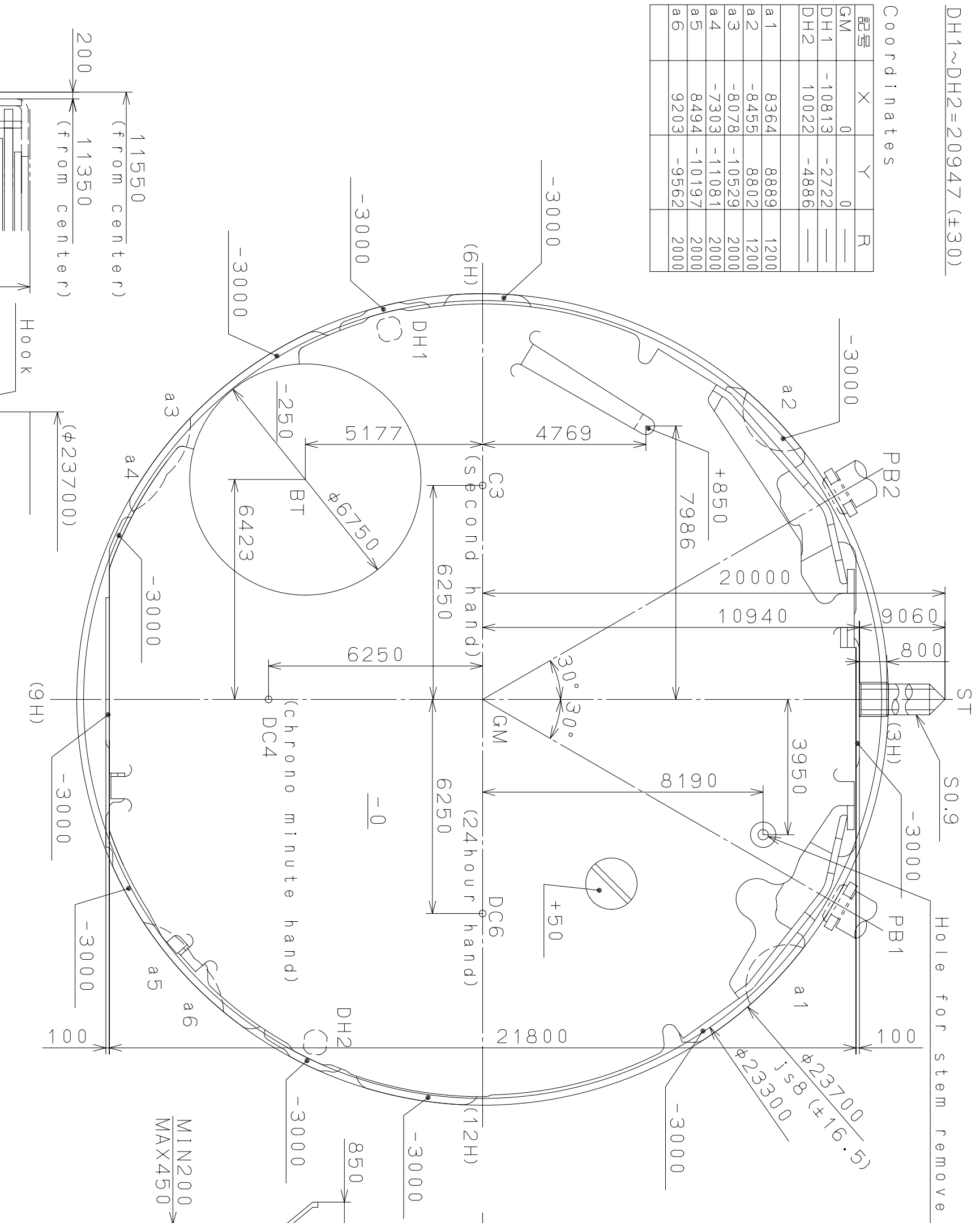

Section PB1,2

Section a1~a6

△	Quantity	Unit	1/1000mm	Cal No.: FS10
△	Scale	8/1	Parts No.:	
△	Date	Drawn	Date	Name
△	Mark	Date	Description	Appr.
△	Material	Alterations		
△	Heat Treatment	General Tolerances		
△	Hardness	Dimensions		
△	Plating	Angles		

Frame for Case
Drawing No.: FS10C000

Frame Name: M. Fukuda

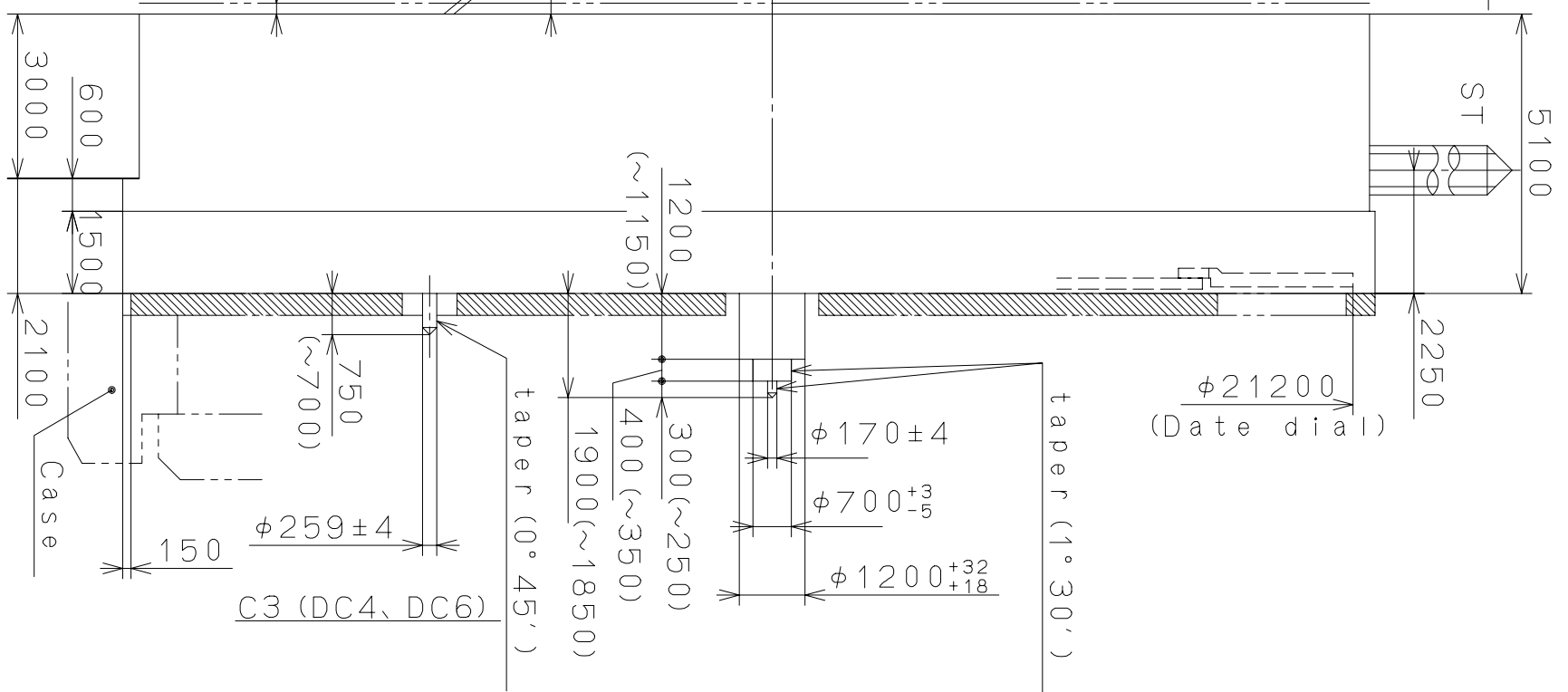

This drawing is provisional and subject to our reconfirmation and/or revision without notice.

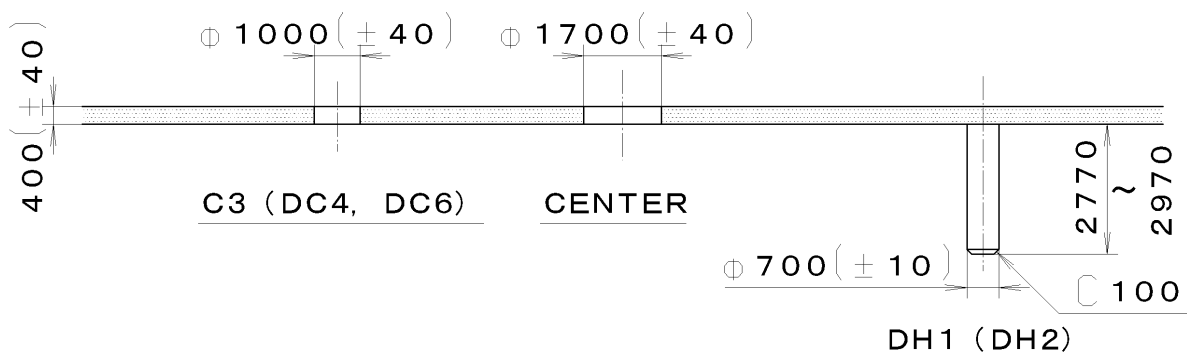
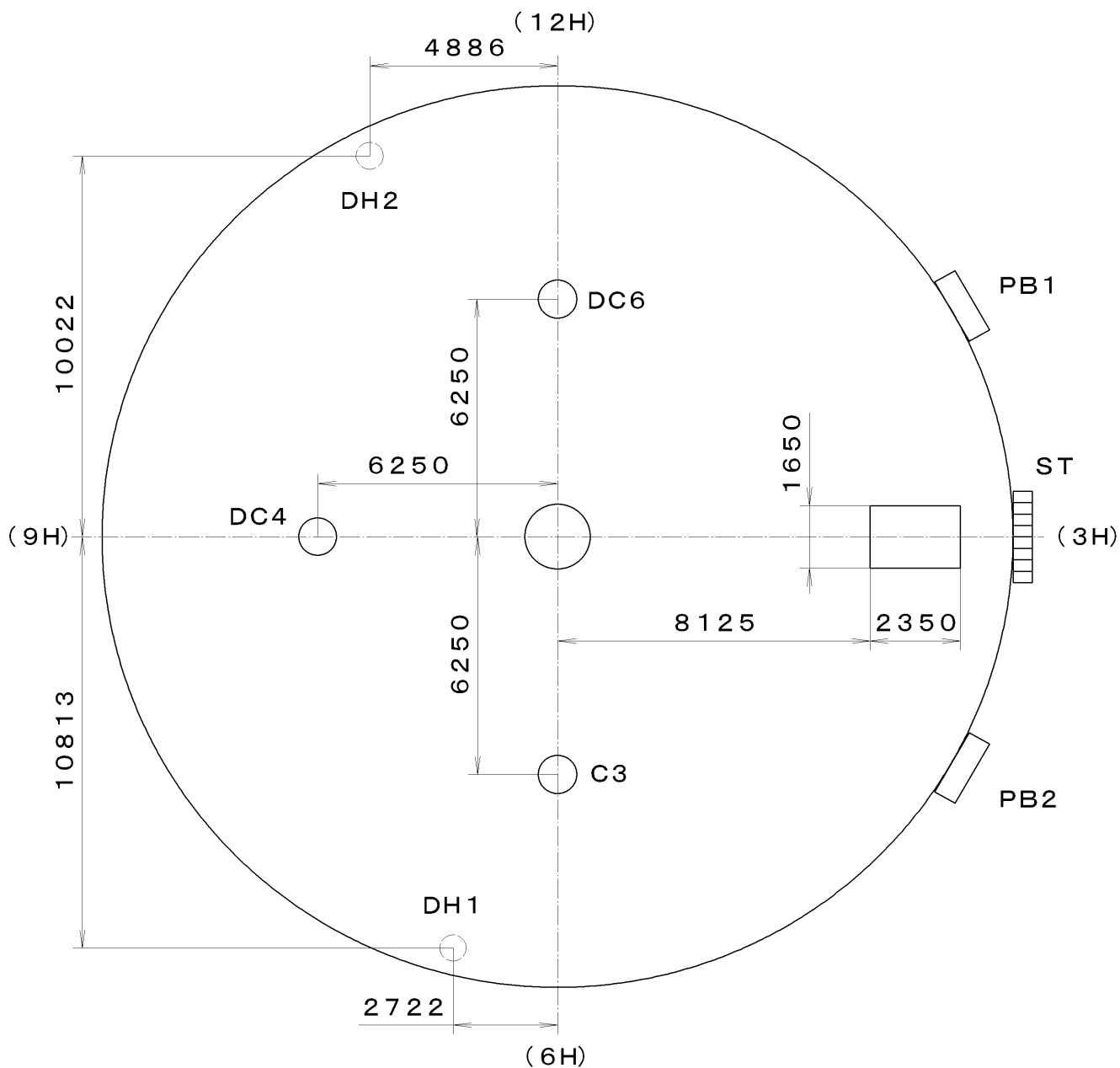

*** T I P W (01) *** (2100 1121) 03-02-14 30.0

7		Quantity		Cal. No. :	FS10-00A
6		Unit	1/1000 mm	Parts:	
5		Scale	6:1	Name:	Indications for Dial
4		Date		Drawing No. :	
3		Drawn		Material	
2		Checked	M. Fukuda	Heat Treatment	
1		Approved		Hardness	
				Plating	
				General Tolerances	
				Dimensions	
				Angles	

confidential papers 2012/06/26 (14:57:38)

This drawing is provisional and subject to our reconfirmation and/or revision without notice.

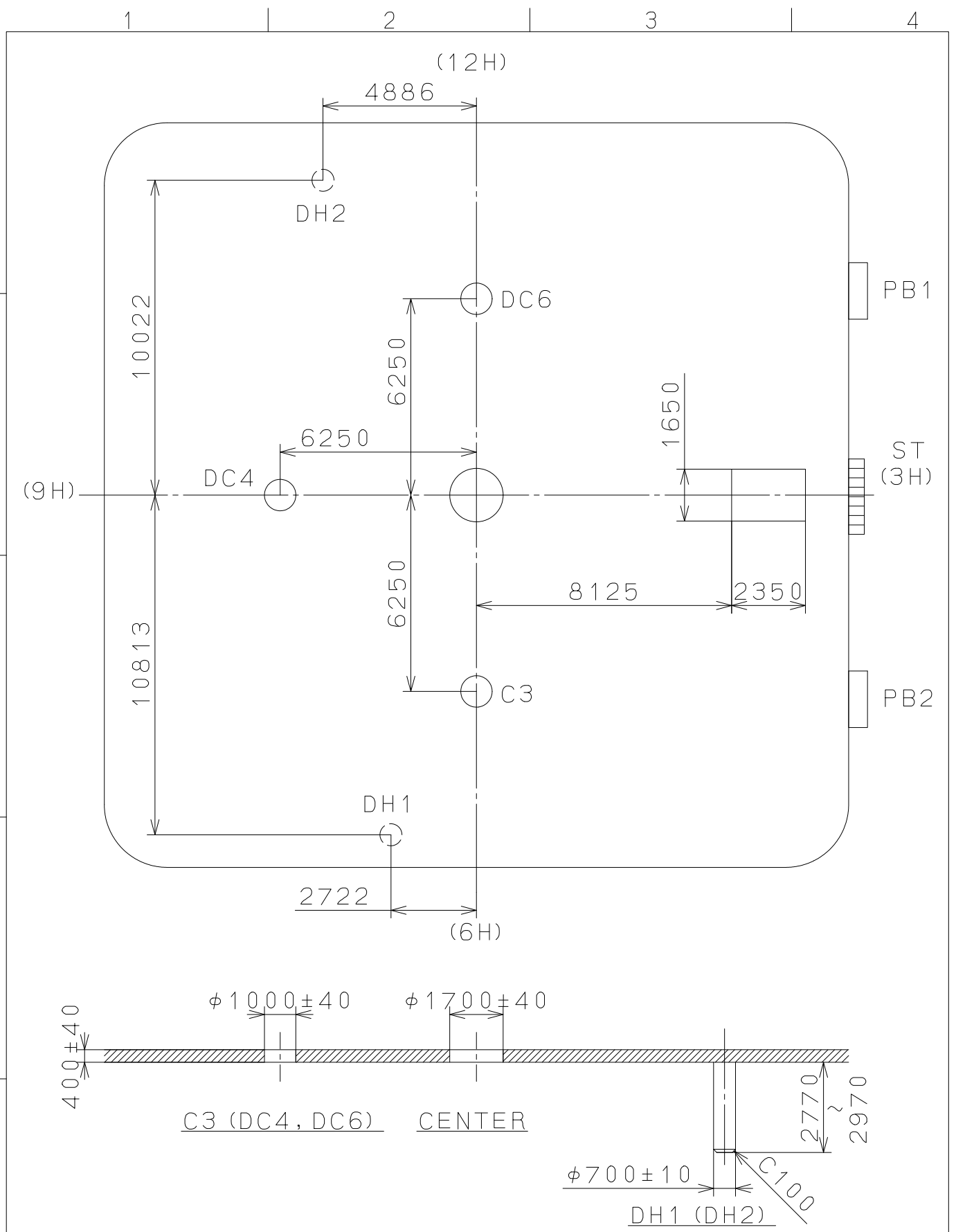

△			Quantity		Cal.NO.:
△			Unit	1/1000 _{mm}	FS11-00A
△			Scale	6:1	Parts No.:
△			Date		
△			Drawn		
Mark	Date	Description	Appr.	Checked	Name:
		Alterations	Approved	N. Suzuki	Indications for Dial
Material					Drawing No.: FS11D000
Heat Treatment			General Tolerances	MIYOTA CITIZEN WATCH CO., LTD. TOKYO, JAPAN	
Hardness			Dimensions		
Plating			Angles		

This drawing is provisional and subject to our reconfirmation and/or revision without notice.

*** T I P W 065-549 (01) *** (2100 1121) 01-12-07

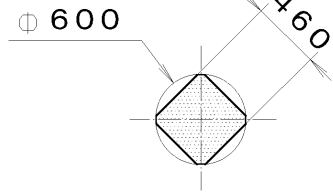

Section A-A

S0. 9, P=0. 225mm

⌀ 1000

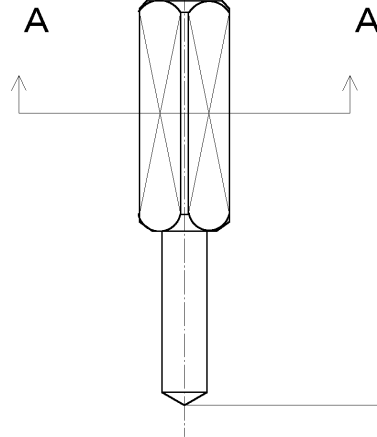

<table border="1"> <tr><td>7</td><td></td></tr> <tr><td>6</td><td></td></tr> <tr><td>5</td><td></td></tr> <tr><td>4</td><td></td></tr> <tr><td>3</td><td></td></tr> <tr><td>2</td><td></td></tr> <tr><td>1</td><td></td></tr> </table>		7		6		5		4		3		2		1		<table border="1"> <tr><td>Quantity</td><td></td></tr> <tr><td>Unit</td><td>1/1000 mm</td></tr> <tr><td>Scale</td><td>20:1</td></tr> <tr><td>Date</td><td></td></tr> <tr><td>Drawn</td><td></td></tr> <tr><td>Checked</td><td>T. Hiruta</td></tr> <tr><td>Approved</td><td></td></tr> </table>		Quantity		Unit	1/1000 mm	Scale	20:1	Date		Drawn		Checked	T. Hiruta	Approved		<table border="1"> <tr><td>Cal. No. :</td><td></td></tr> <tr><td>Parts:</td><td>065-549</td></tr> <tr><td>Name:</td><td>SETTING STEM</td></tr> <tr><td>Drawing No. :</td><td>5490S000</td></tr> </table>		Cal. No. :		Parts:	065-549	Name:	SETTING STEM	Drawing No. :	5490S000
7																																									
6																																									
5																																									
4																																									
3																																									
2																																									
1																																									
Quantity																																									
Unit	1/1000 mm																																								
Scale	20:1																																								
Date																																									
Drawn																																									
Checked	T. Hiruta																																								
Approved																																									
Cal. No. :																																									
Parts:	065-549																																								
Name:	SETTING STEM																																								
Drawing No. :	5490S000																																								
<table border="1"> <tr><td>Material</td><td></td></tr> <tr><td>Heat Treatment</td><td></td></tr> <tr><td>Hardness</td><td></td></tr> <tr><td>Plating</td><td></td></tr> </table>		Material		Heat Treatment		Hardness		Plating		<table border="1"> <tr><td>General Tolerances</td><td></td></tr> <tr><td>Dimensions</td><td></td></tr> <tr><td>Angles</td><td></td></tr> </table>		General Tolerances		Dimensions		Angles		<p>CITIZEN WATCH CO., LTD. TOKYO, JAPAN</p>																							
Material																																									
Heat Treatment																																									
Hardness																																									
Plating																																									
General Tolerances																																									
Dimensions																																									
Angles																																									