

This drawing is provisional and subject to our reconfirmation and/or revision without notice.

DH3~DH4=22287 (±20)

Coordinates			
記号	X	Y	R
GM	0	0	—
DH3	-8759	6900	—
DH4	8251	-7500	—
b1	7996	7871	530
b2	8624	7608	150
b3	10099	5501	150
b4	10131	4822	530
b5	7803	-8063	530
b6	7535	-8688	150
b7	5416	-10145	150
b8	4736	-10171	530
b9	-7996	-7871	530
b10	-8624	-7608	150
b11	-10099	-5501	150
b12	-10131	-4822	530
b13	-7803	8063	530
b14	-7535	8688	150
b15	-5416	10145	150
b16	-4736	10171	530

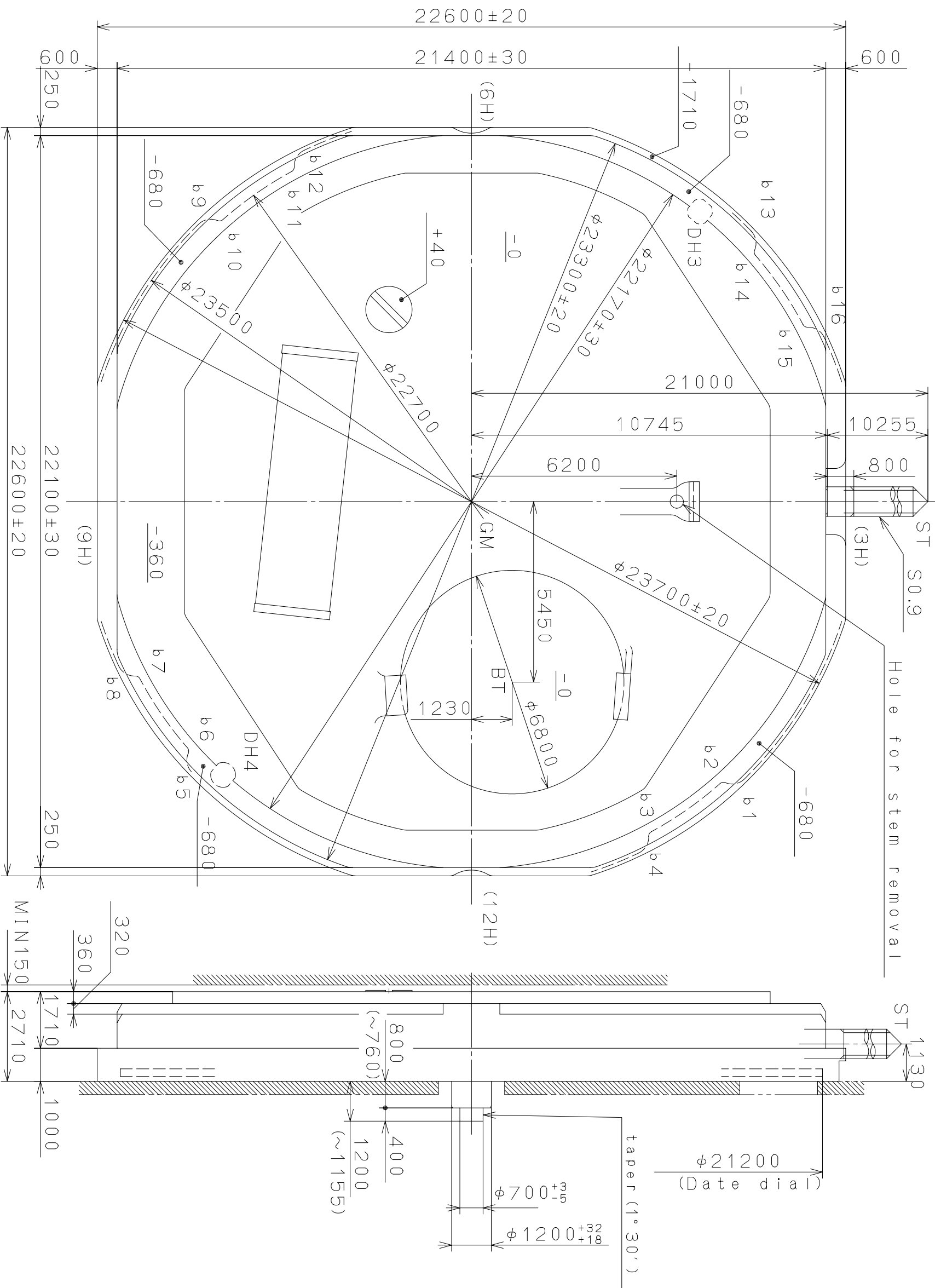
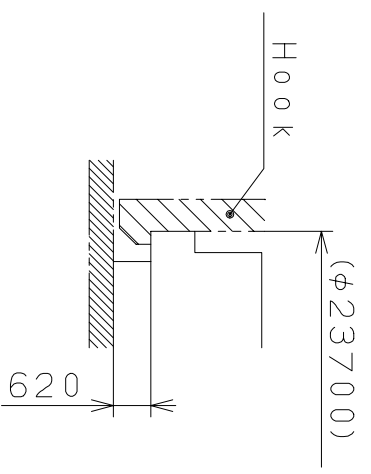

Section b1~b16

△	Quantity	1 / 1000 mm	Cal. NO.: GM15
△	Unit	8 / 1	Parts No.:
△	Scale	Date	Name
△	Drawn	M. Fukuda Name: Frame for Case	
△	Date	Checked	Approved
△	Description	Drawing No.: GM15C000	
△	Alterations		
△	Material	General Tolerances	
△	Heat Treatment	Dimensions	
△	Hardness	Angles	
△	Plating		

This drawing is provisional and subject to our reconfirmation and/or revision without notice.

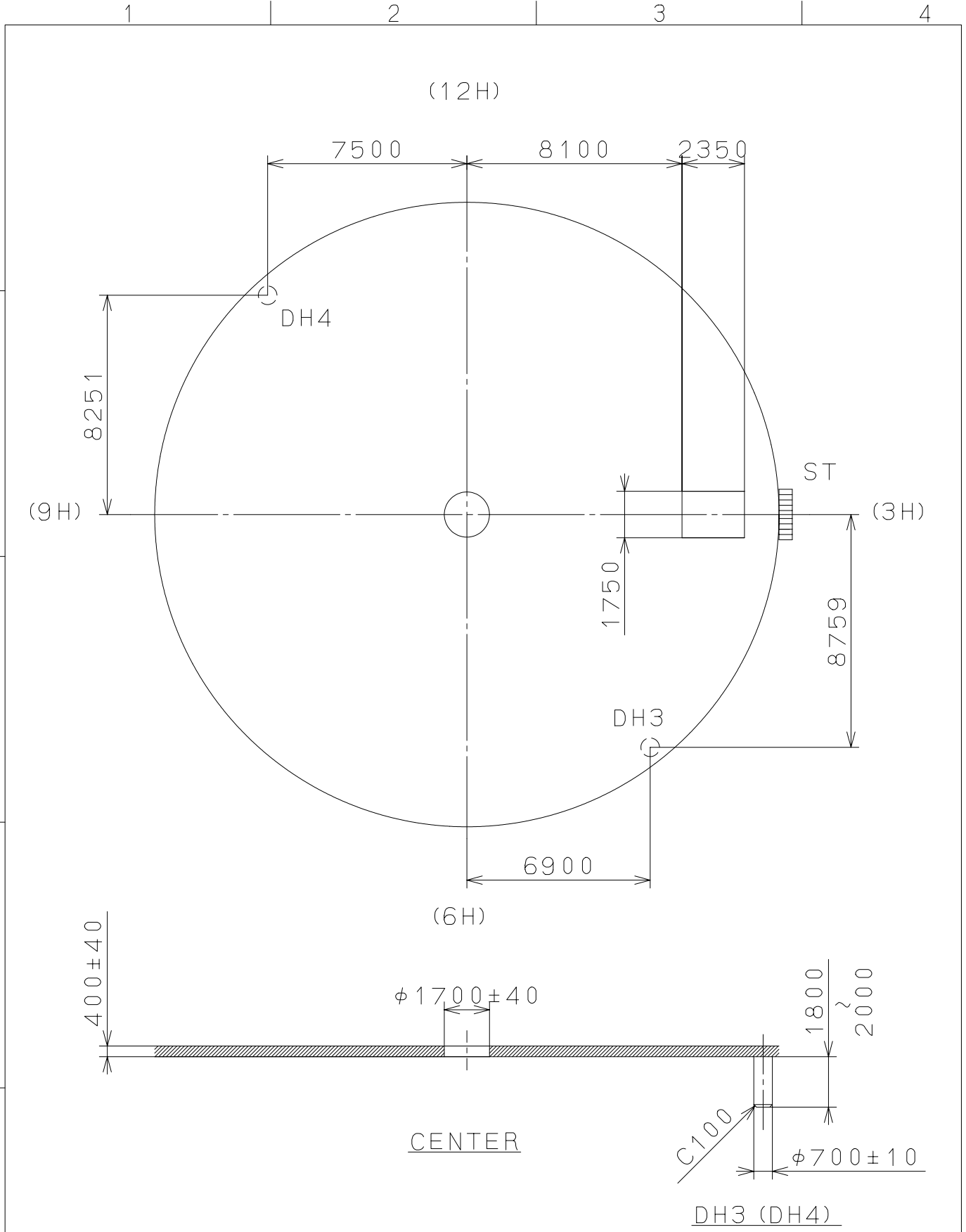

△5			Quantity			Cal. NO.: GM15-00A
△4			Unit	1 / 1000 mm		
△3			Scale	5 / 1		Parts No.:
△2				Date	Name	
△1			Drawn			
Mark	Date	Description	Appr.	Checked	M. Fukuda	Name:
Alterations			Approved			Indications for Dial
Material					Drawing No.: GM15D000	
Heat Treatment					General Tolerances	
Hardness					Dimensions	
Plating					Angles	