

This drawing is provisional and subject to our reconfirmation and/or revision without notice.

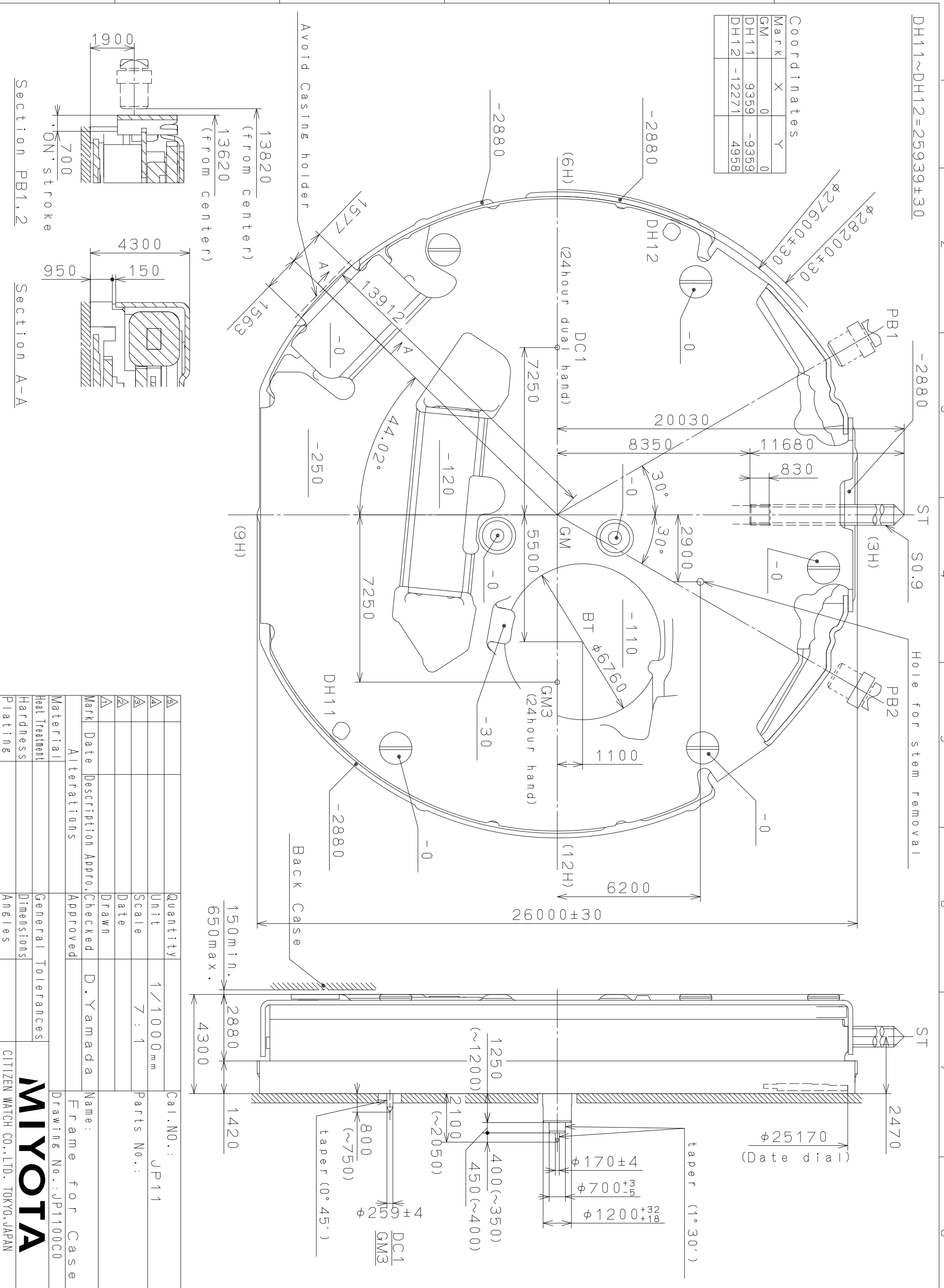

Coordinates

Mark	X	Y
GM	0	0
DH11	9359	-9359
DH12	-12271	4958

△5	Quantity		Cal. NO.:	JP11
△4	Unit	1/1000 mm	Parts No.:	
△3	Scale	7 : 1		
△2	Date			
△1	Drawn			

Material	Alterations	Date	Description	Appro.	Checked	D. Yamada	Name:	Frame for Case
Heat Treatment				Approved				Drawing No.: JP1100C0
Hardness								
Plating								

MIYOTA
CITIZEN WATCH CO., LTD. TOKYO, JAPAN

This drawing is provisional and subject to our reconfirmation and/or revision without notice.

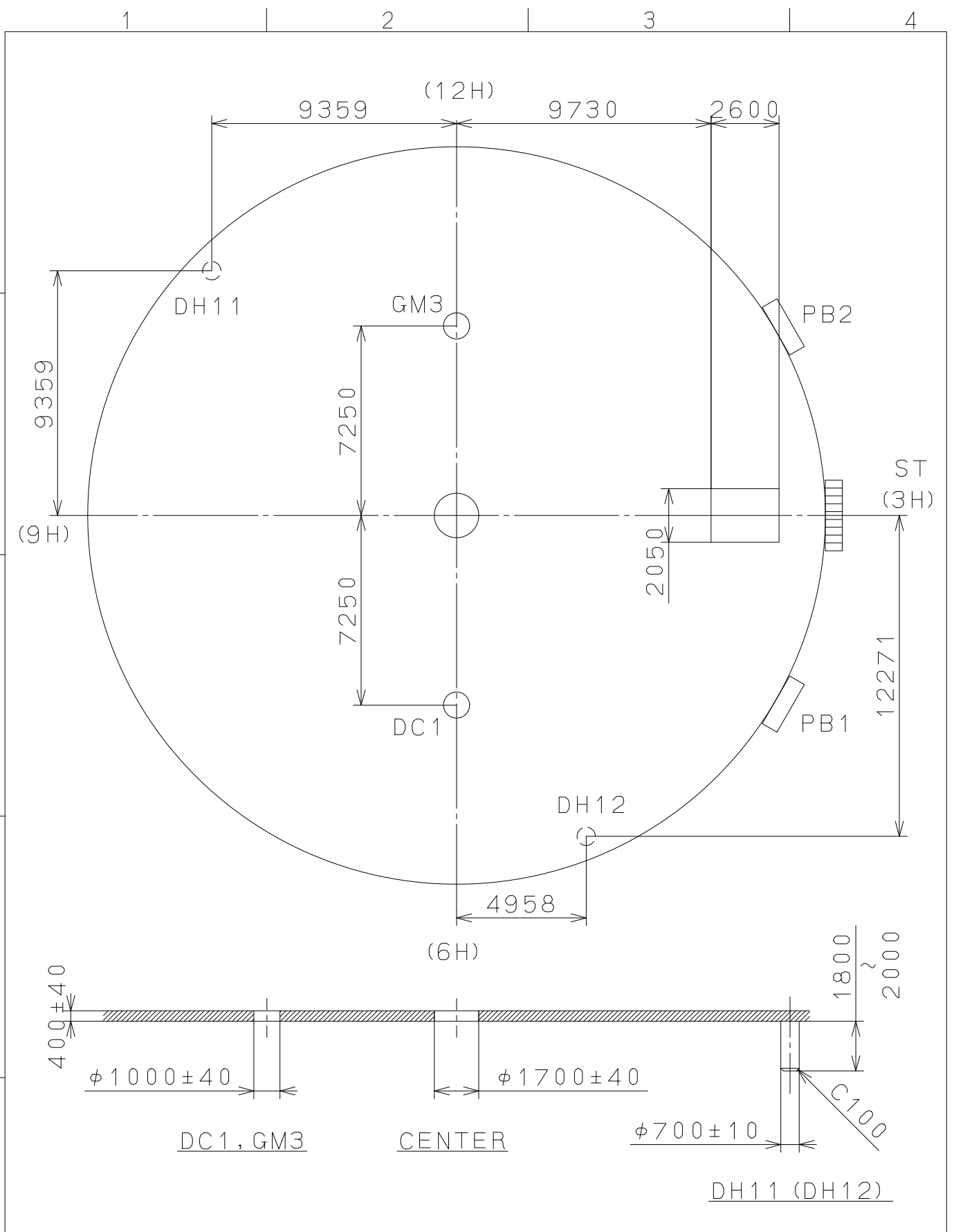

△			Quantity		Cal.NO.:
△			Unit	1 / 1000 mm	JP11-00C
△			Scale	5 : 1	Parts No.:
△			Date		
△			Drawn		
Mark	Date	Description	Appr.	Checked	Name:
		Alterations		Approved	D. Yamada
Material					Indications for Dial
Heat Treatment					Drawing No.: JP1100D0
Hardness				General Tolerances	MIYOTA
Plating				Dimensions	
				Angles	CITIZEN WATCH CO., LTD. TOKYO, JAPAN

This drawing is provisional and subject to our reconfirmation and/or revision without notice.

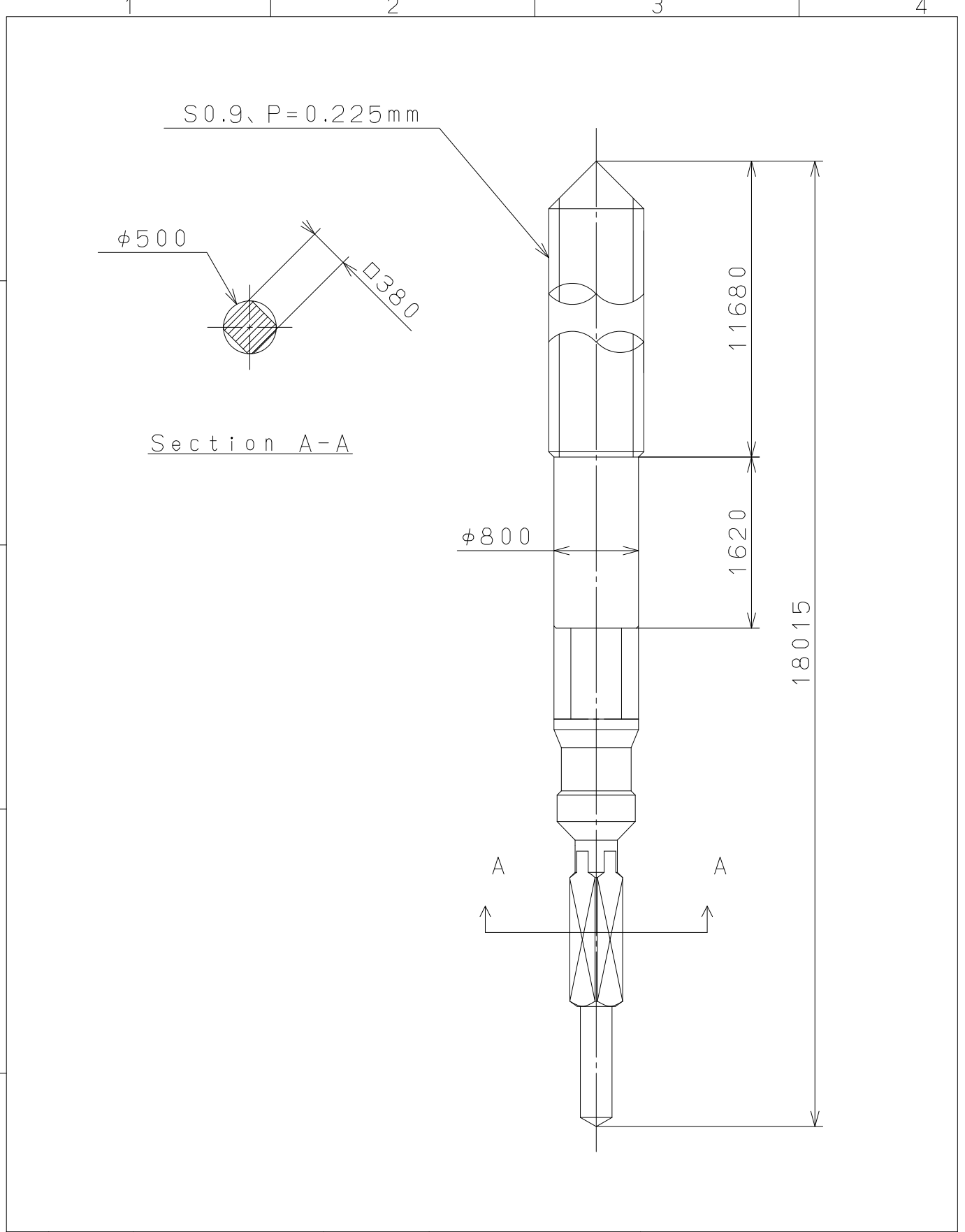

⑤			Quantity		Cal.NO.:
④			Unit	1 / 1000 mm	
③			Scale	20 : 1	Parts No.:
②			Date		065-505
①			Drawn		
Mark	Date	Description	Appro.	Checked	D. Yamada
Alterations			Approved	Name: SETTING STEM	
Material					Drawing No.: 505000S0
Heat Treatment					MIYOTA CITIZEN WATCH CO., LTD. TOKYO, JAPAN
Hardness					
Plating					