

Mark	X	Y	R
GM	0	0	—
a1	-7838	-4250	500
a2	-6550	-4855	300
a3	-5951	-4888	300
a4	6101	-4790	300
a5	6700	-4756	300

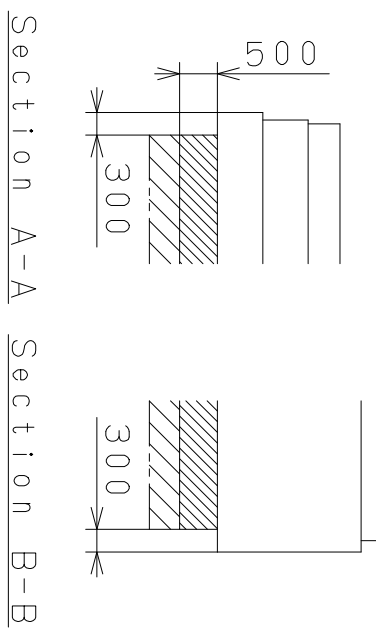

Mark	Date	Description	Apporo.	Checked	Drawn	Quantity	Unit	Cal. NO.:
△5						1	1/1000 mm	2025
△A								10:1
△A								
△A								
Material	Alterations					Approved		
Heat Treatment						D. Yamada		
Hardness						Name: Frame for Case		
Plating						Drawing No.: 202500C0		

MIYOTA
CITIZEN WATCH CO., LTD. TOKYO, JAPAN

This drawing is provisional and subject to our reconfirmation and/or revision without notice.

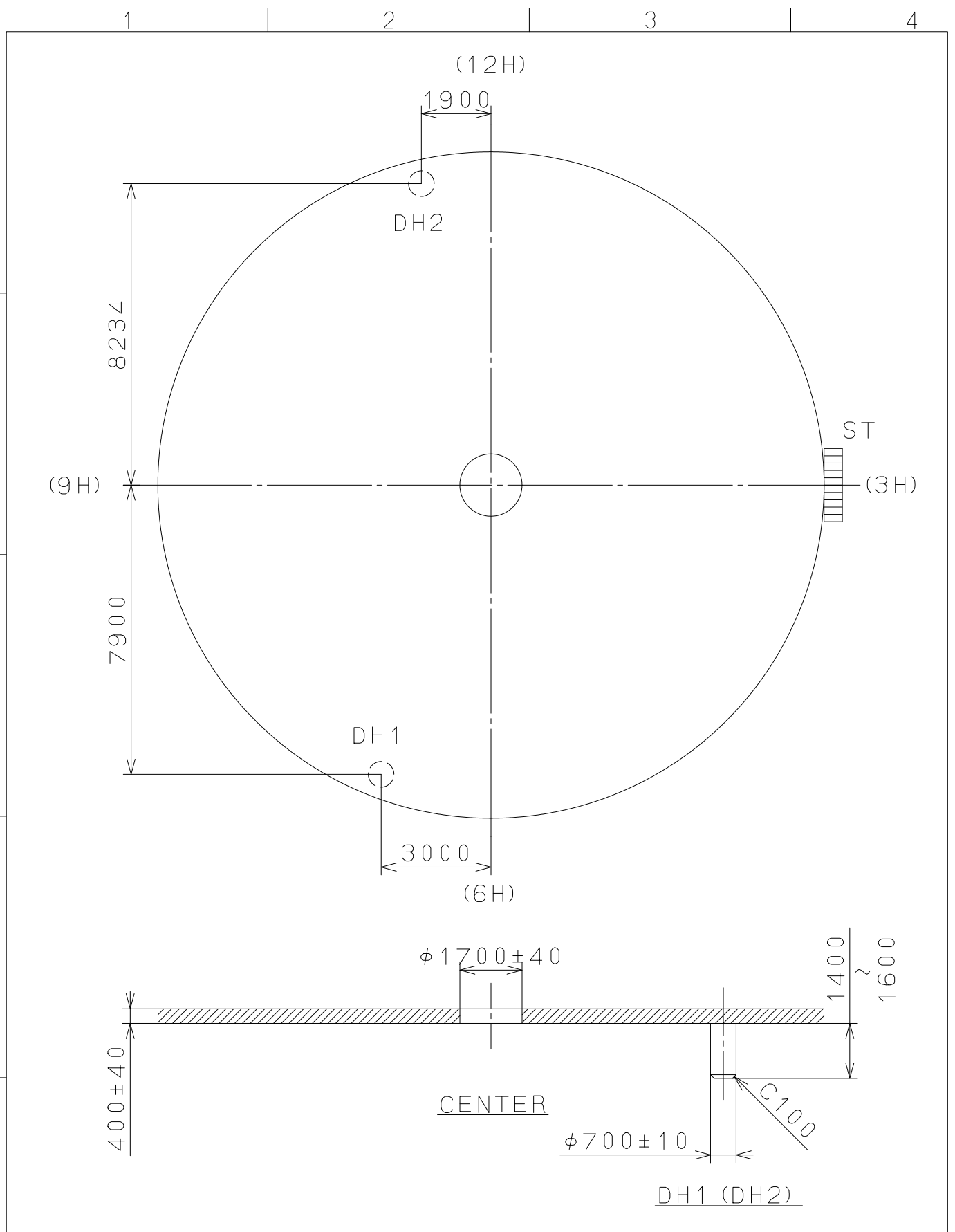

△			Quantity		Cal.NO.:
△			Unit	1 / 1000 mm	2025-00A
△			Scale	7 : 1	Parts No.:
△			Date		
△			Drawn		
Mark	Date	Description	Appr.	Checked	Name:
		Alterations	Approved	D. Yamada	Indications for Dial
Material					Drawing No.: 202500D0
Heat Treatment			General Tolerances		MIYOTA
Hardness			Dimensions		
Plating			Angles		
					CITIZEN WATCH CO., LTD. TOKYO, JAPAN

This drawing is provisional and subject to our reconfirmation and/or revision without notice.

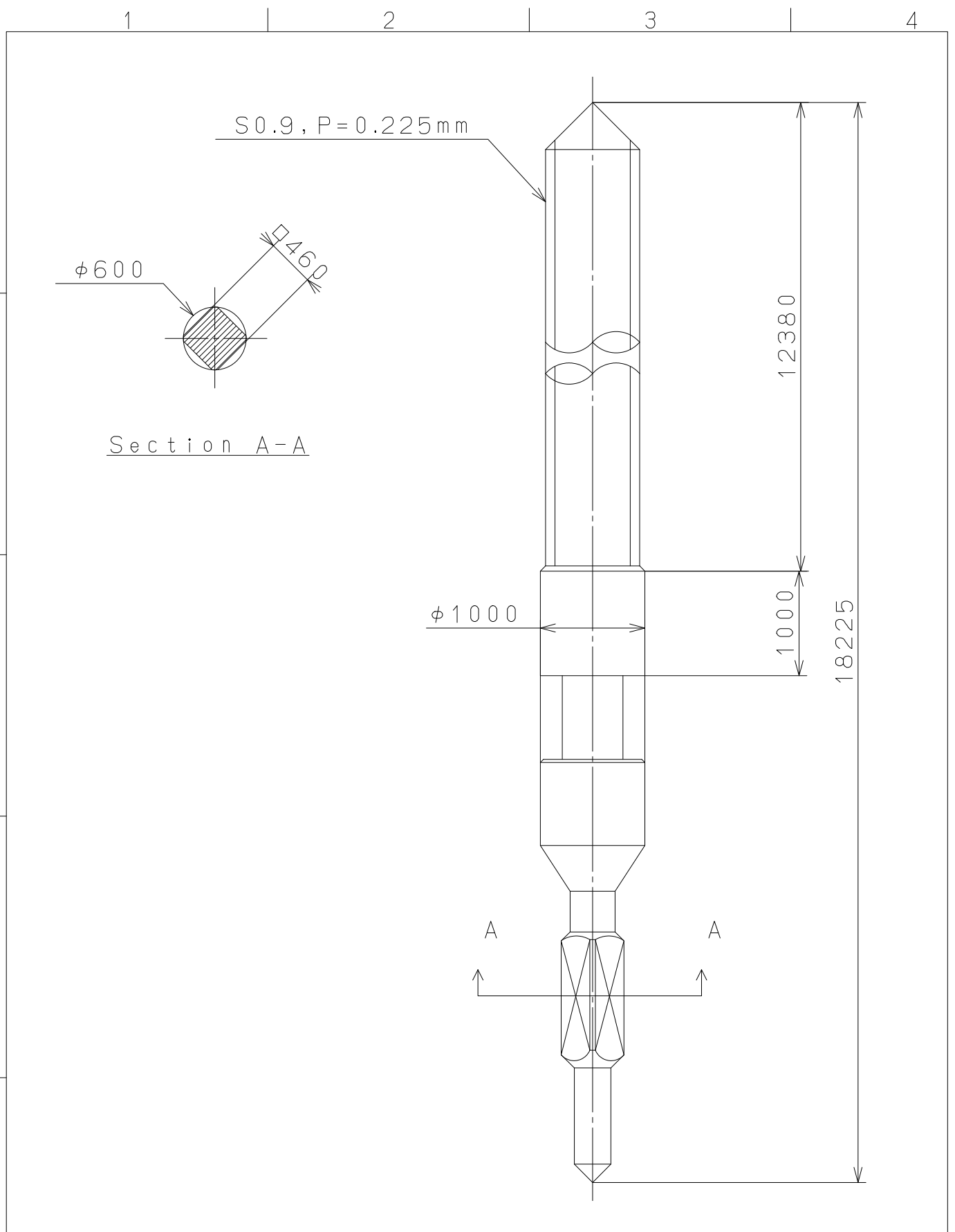

△5			Quantity		Cal.NO.:
△4			Unit	1 / 1000 mm	
△3			Scale	20 : 1	Parts No.:
△2			Date		065-468
△1			Drawn		
Mark	Date	Description	Appro.	Checked	Name:
		Alterations	Approved	D. Yamada	SETTING STEM
Material					Drawing No.: 468000S0
Heat Treatment			General	Tolerances	MIYOTA
Hardness			Dimensions		
Plating			Angles		
					CITIZEN WATCH CO., LTD. TOKYO, JAPAN