

This drawing is provisional and subject to our reconfirmation and/or revision without notice.

DH5~DH6=222287 (±20)

Coordinates

記号	X	Y	R
GM	0	0	—
DH5	-8759	6900	—
DH6	8251	-7500	—
a1	2351	11100	200
a2	7235	9131	200
a3	10800	3490	500
a4	10800	-3490	500
a5	3490	-10800	500
a6	-2700	-11100	200
a7	-5389	-10216	300
a8	-10800	-3490	500
a9	-10800	3490	500
a10	-3490	10800	500
b1	9581	6360	150
b2	7928	8331	150
b3	-5773	9946	150
b4	-7839	8415	150
b5	-9572	-6374	150
b6	-7916	-8342	150
b7	9196	-6906	150
b8	10501	-4690	150

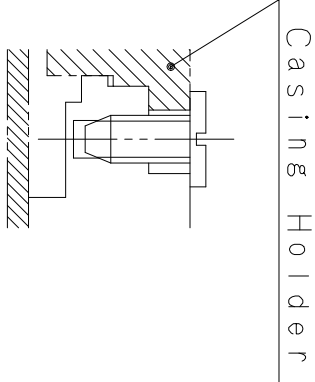
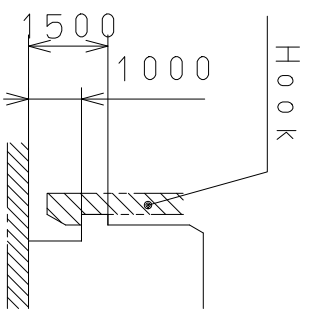
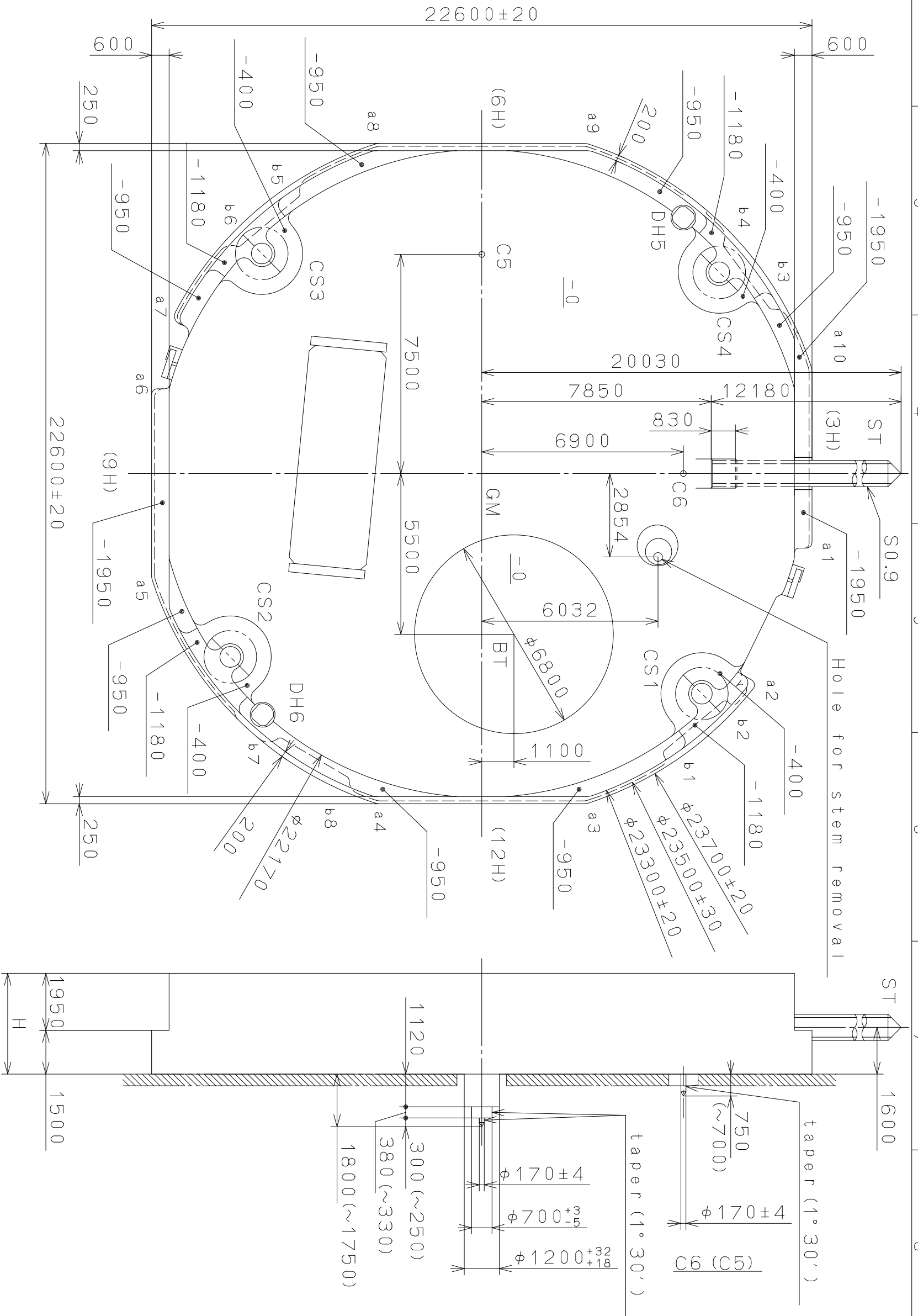

With Battery strap	H
Without Battery strap	3450

Quantity	Unit	Cal. NO.:
1	1/1000 mm	6P22
Scale	7:1	Parts No.:
Date	Drawn	Name:
Date	Checked	E. Murakami
Date	Approved	Frame for Case
Material		
Heat Treatment		
Hardness		
Plating		
Alterations		
Date		
Description		
Appr.:		
Checked		
Approved		
General Tolerances		
Dimensions		
Angles		
Drawing No.: 6P22C000		

This drawing is provisional and subject to our reconfirmation and/or revision without notice.

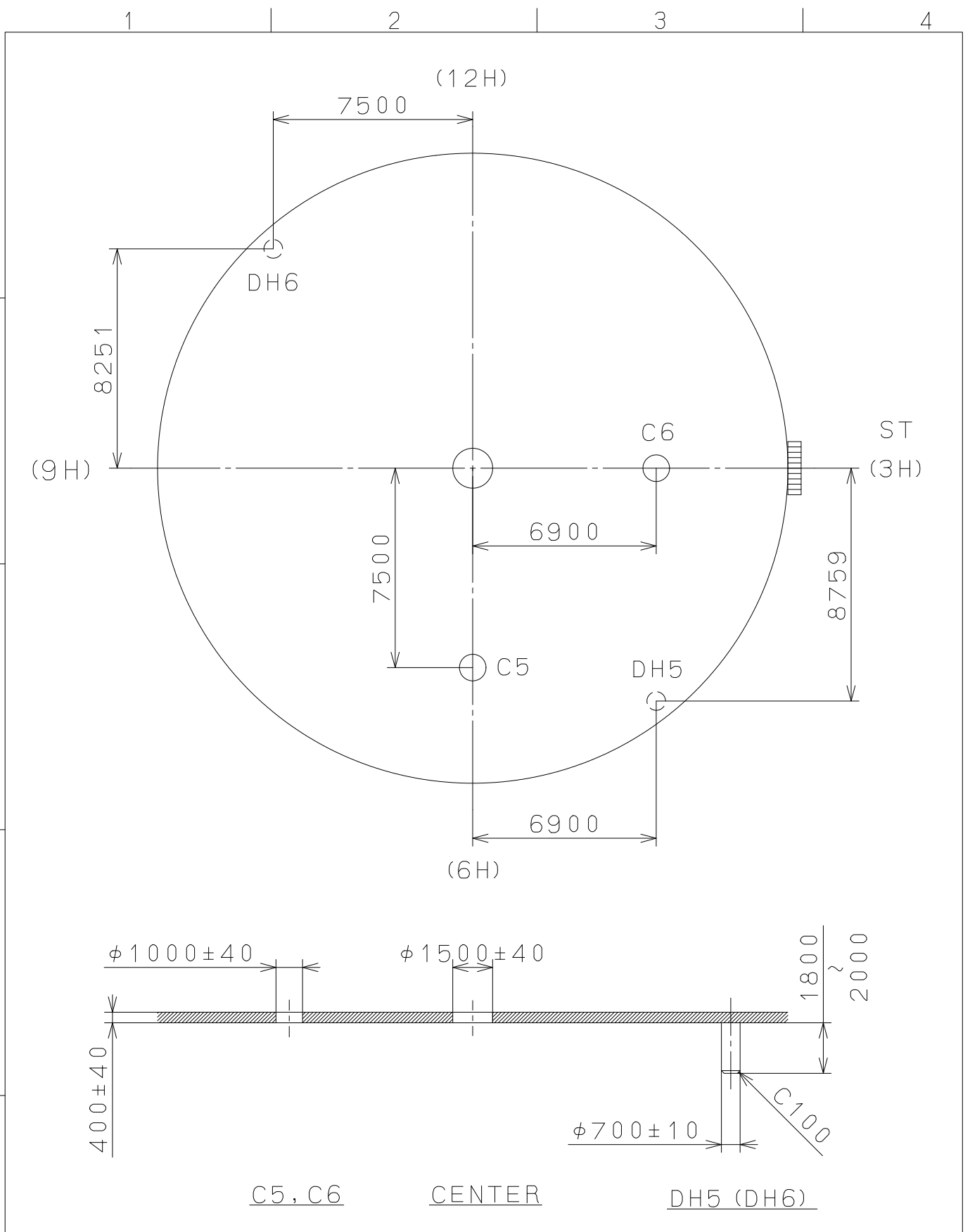

△			Quantity		Cal.NO.:
△			Unit	1 / 1000 mm	6P22-00A
△			Scale	5 : 1	Parts No.:
△			Date		
△			Drawn		
Mark	Date	Description	Appro.	Checked	Name:
		Alterations	Approved	E. Murakami	Indications for Dial
Material					Drawing No.: 6P22D000
Heat Treatment			General Tolerances	<b>MIYOTA</b> CITIZEN WATCH CO., LTD. TOKYO, JAPAN	
Hardness			Dimensions		
Plating			Angles		

2010/05/12 (17:15:34)

This drawing is provisional and subject to our reconfirmation and/or revision without notice.

A  
B  
C  
D  
E  
F

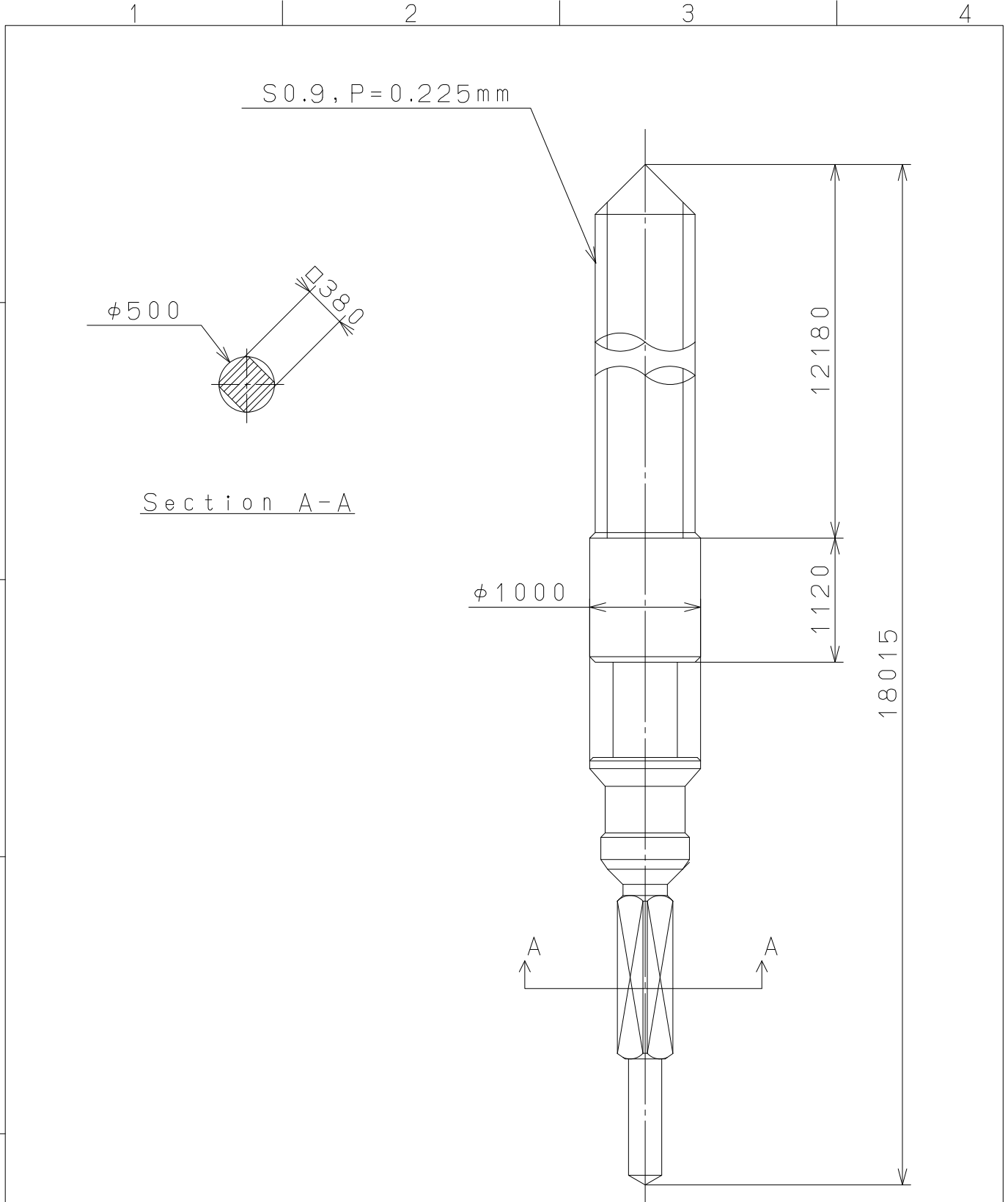

△5			Quantity		Cal.NO.:
△4			Unit	1/1000mm	
△3			Scale	20:1	Parts No.:
△2			Date		065-379
△1			Drawn		
Mark	Date	Description	Appr.	Checked	T.Hiruta
Alterations			Approved	Name:	
					SETTING STEM
Material				Drawing No.:3790S000	
Heat Treatment				General Tolerances	
Hardness				Dimensions	
Plating				Angles	
				<b>MIYOTA</b>	
				CITIZEN WATCH CO.,LTD. TOKYO,JAPAN	