

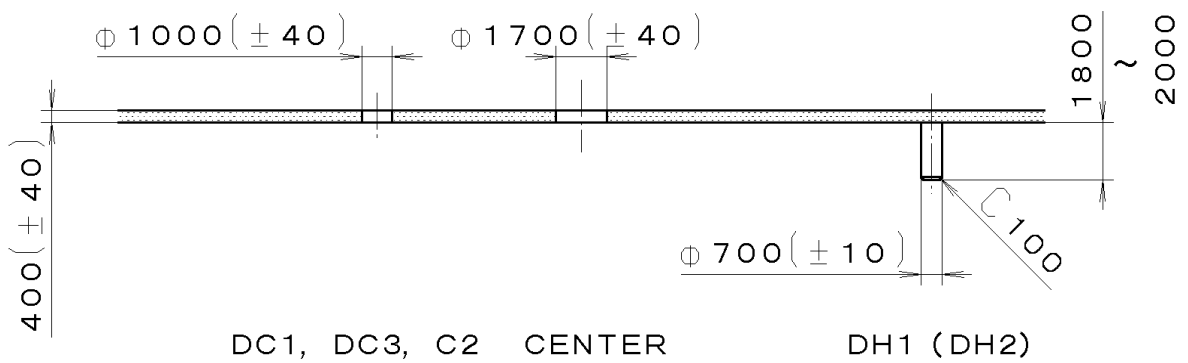

This drawing is provisional and subject to our reconfirmation and/or revision without notice.

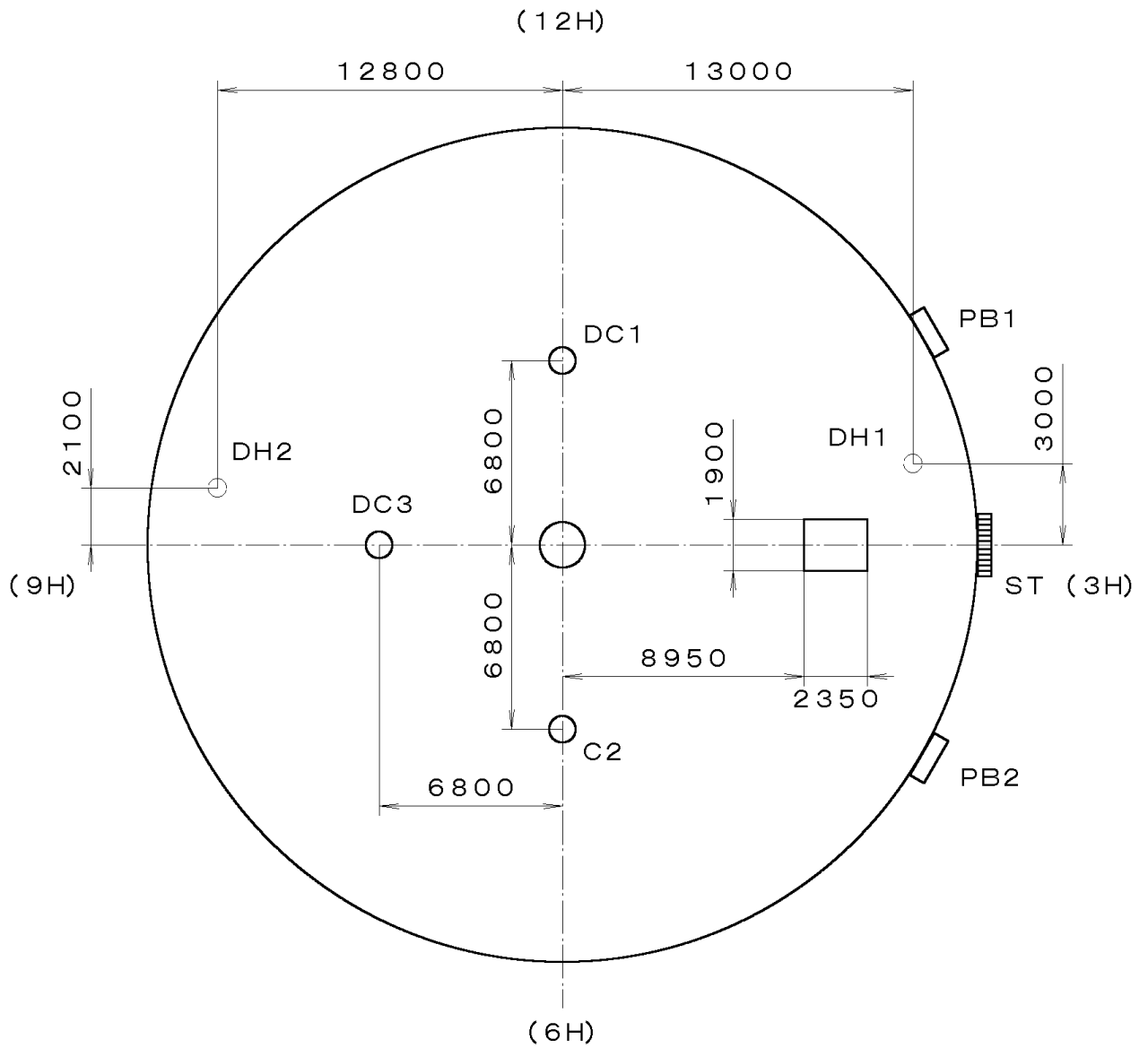

DC1, DC3, C2 CENTER      DH1 (DH2)

OS10-00A (01) *** (2100 1121) 00-07-05 *** T I P W	7		Quantity		Cal. No. : OS10-00A OS60-00A
	6		Unit	1/1000 mm	
	5		Scale	4:1	Parts:
	4		Date		
	3		Drawn		
	2		Checked	T. Hiruta	Name:
	1		Approved		Indications for Dial
Material					Drawing No. : OS10D000
Heat Treatment			General Tolerances		<b>MIYOTA</b>
Hardness			Dimensions		
Plating			Angles		

This drawing is provisional and subject to our reconfirmation and/or revision without notice.

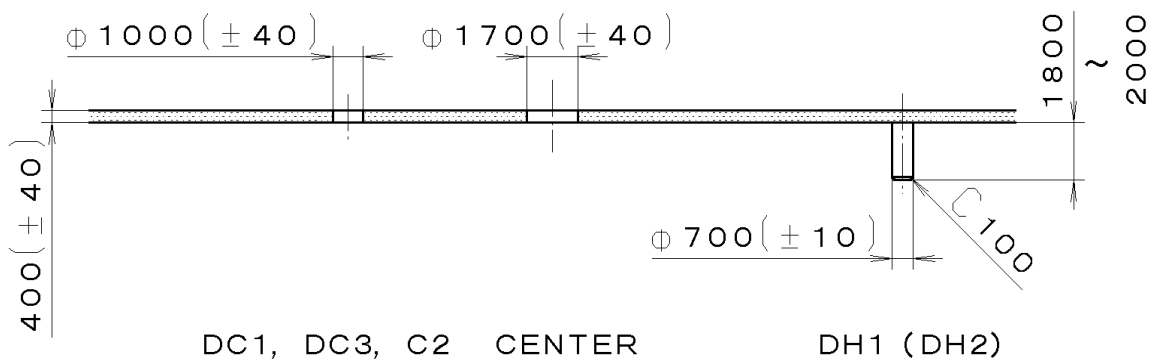
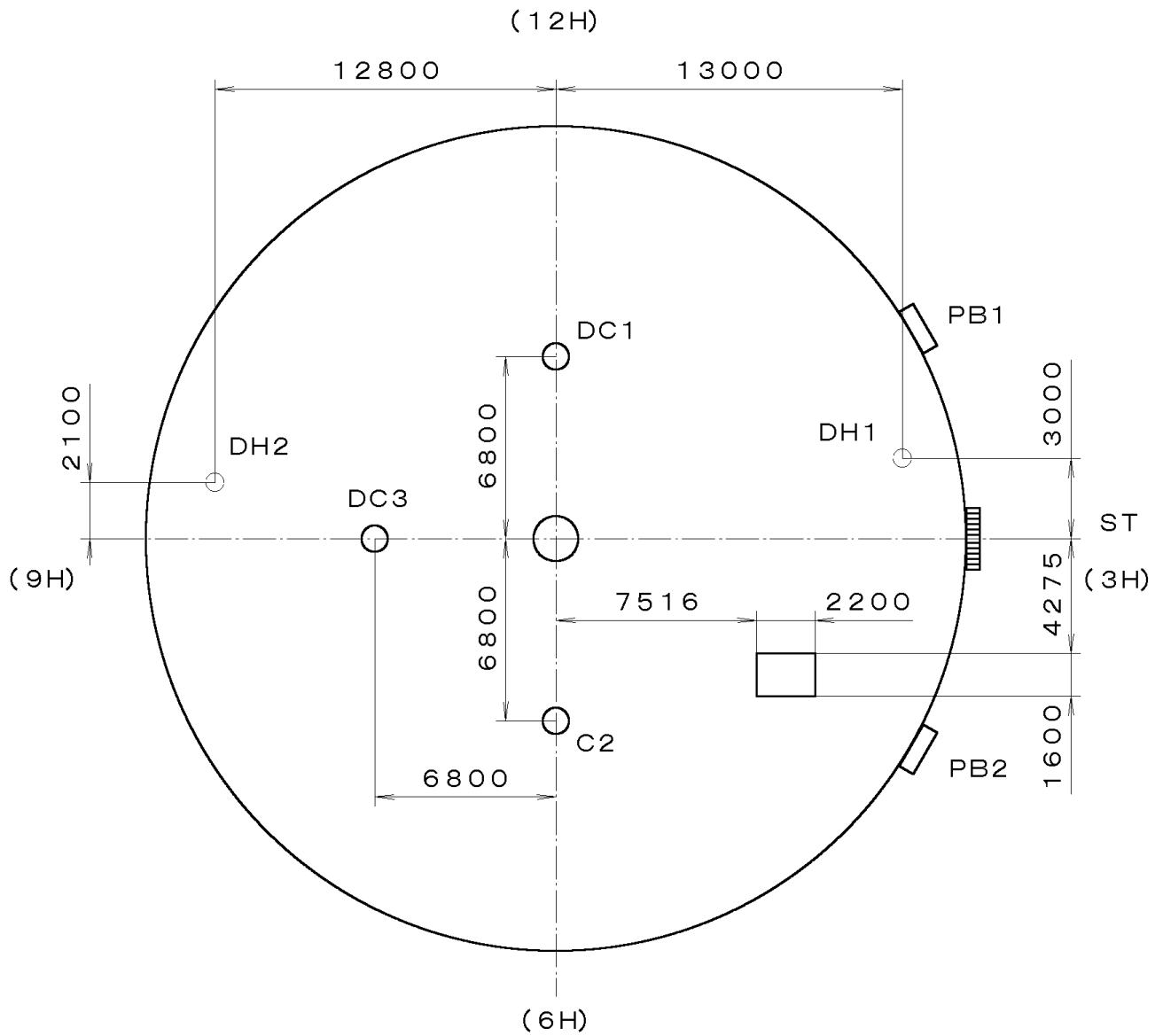

DC1, DC3, C2 CENTER

DH1 (DH2)

OS10-00S (01) *** (2100 1121) 00-07-05 30.5 *** T I P W	7		Quantity		Cal. No. : OS10-00S OS60-00S
	6		Unit	1/1000 mm	
	5		Scale	4:1	Parts :
	4		Date		
	3		Drawn		
	2		Checked	T. Hiruta	Name : Indications for Dial
	1		Approved		
Material					Drawing No. : OS10D010
Heat Treatment			General Tolerances		<h1>MIYOTA</h1>
Hardness			Dimensions		
Plating			Angles		

This drawing is provisional and subject to our reconfirmation and/or revision without notice.

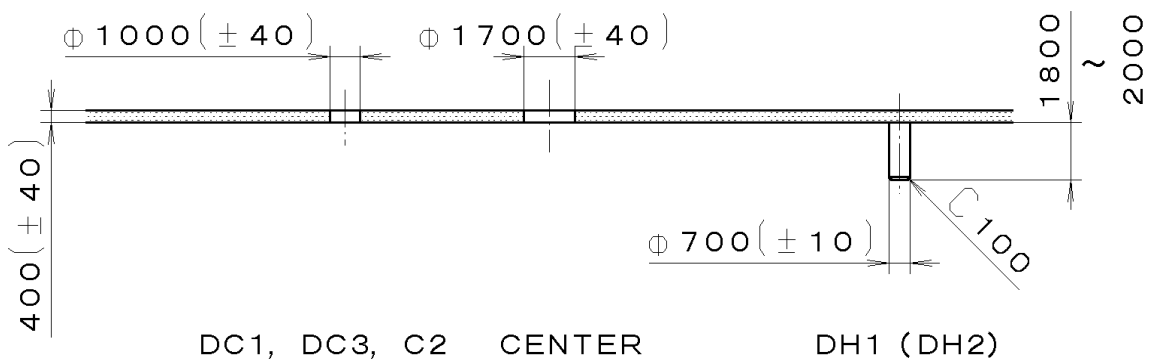
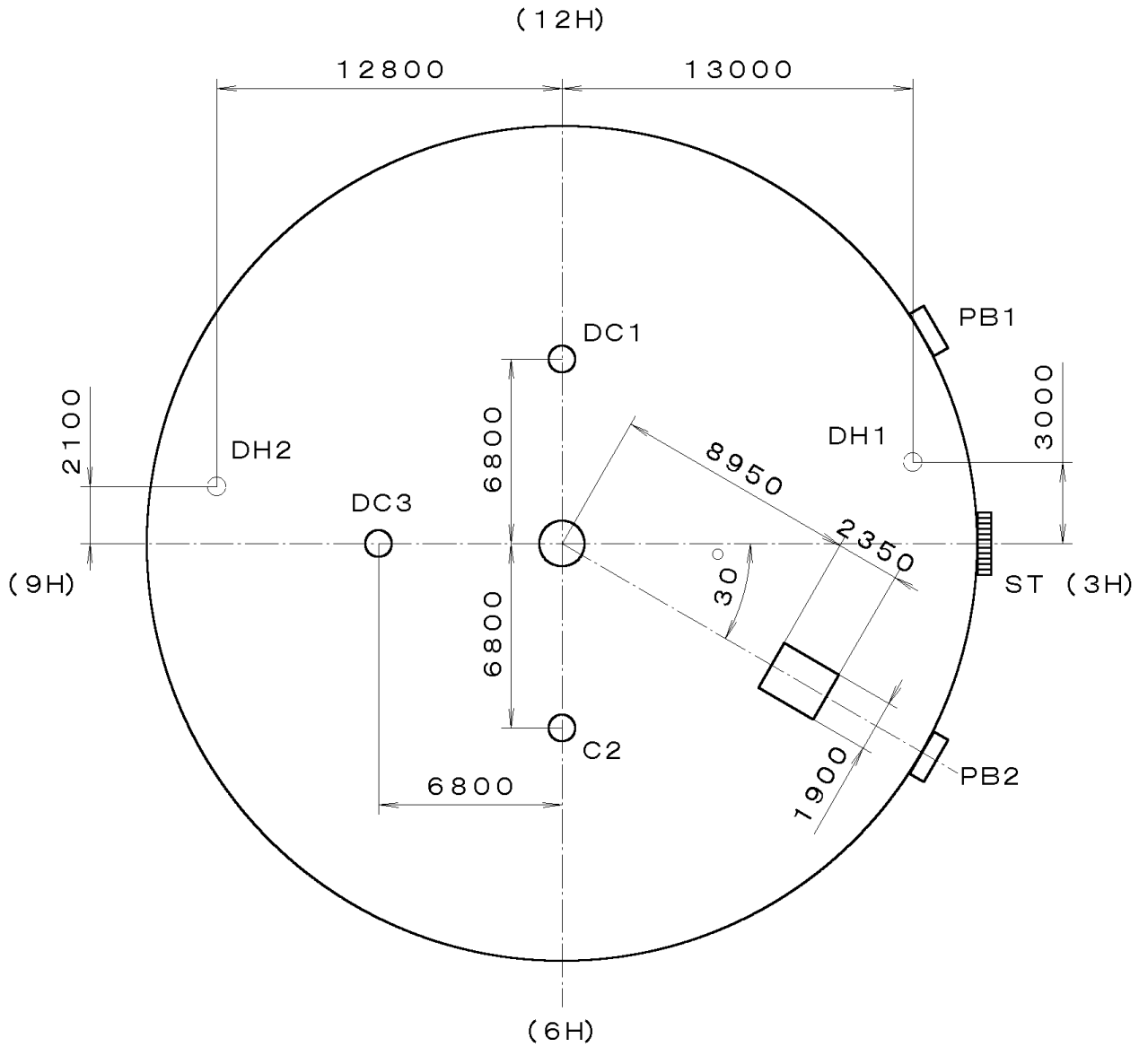

DC1, DC3, C2 CENTER DH1 (DH2)

OS10-00U (01) *** (2100 1121) 00-07-05 *** T I P W	7		Quantity		Cal. No. : OS10-00U OS60-00U
	6		Unit	1/1000 mm	
	5		Scale	4:1	Parts:
	4		Date		
	3		Drawn		
	2		Checked	T. Hiruta	Name:
	1		Approved		Indications for Dial
Material				Drawing No. : OS10D020	
Heat Treatment			General Tolerances	<b>MIYOTA</b>	
Hardness			Dimensions		
Plating			Angles		

This drawing is provisional and subject to our reconfirmation and/or revision without notice.

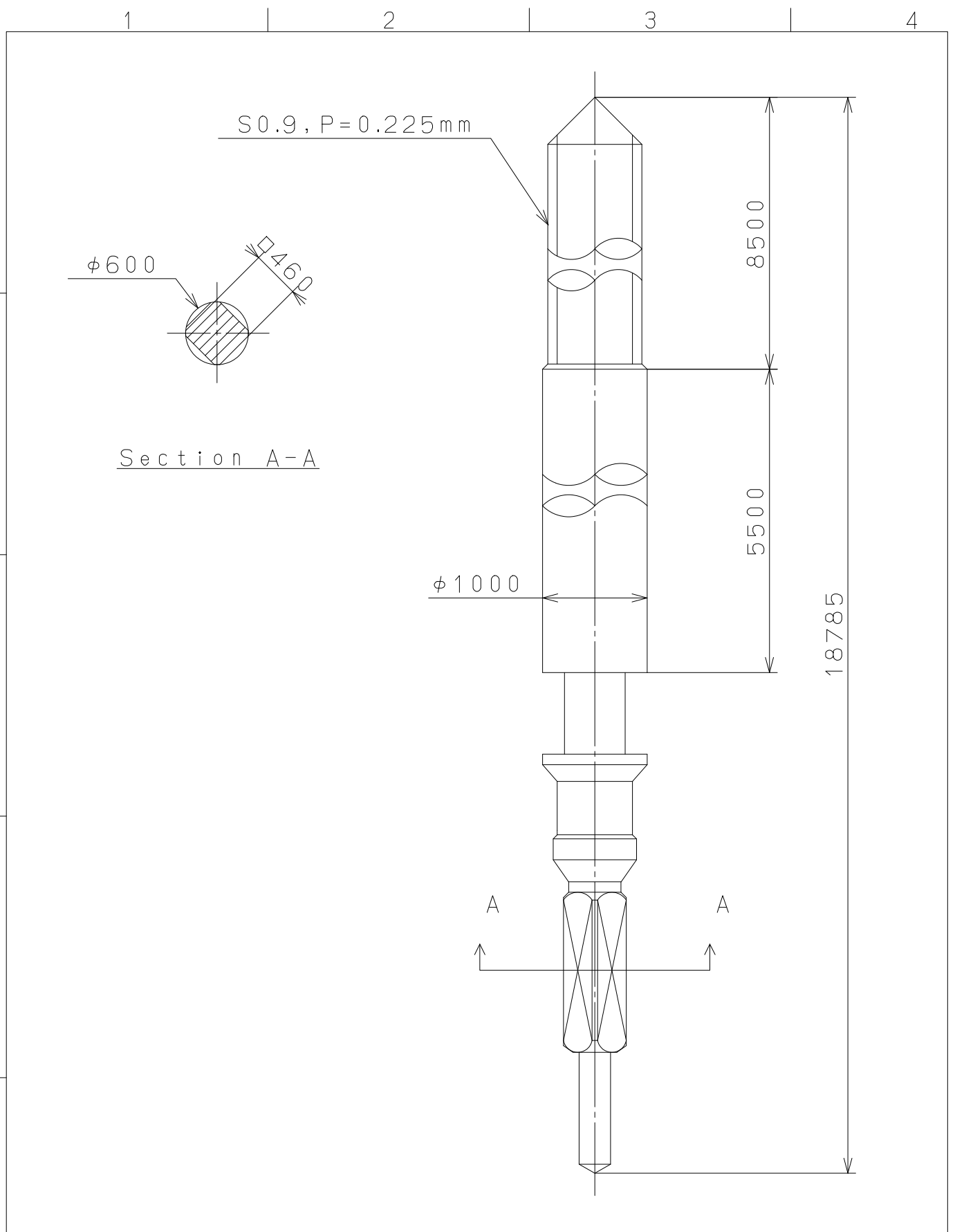

△5			Quantity		Cal.NO.:	
△4			Unit	1 / 1000 mm		
△3			Scale	20 : 1	Parts No.:	
△2			Date		065-453	
△1			Drawn			
Mark	Date	Description	Appr.	Checked	E. Murakami	Name:
Alterations			Approved	SETTING STEM		
Material					Drawing No.: 4530S000	
Heat Treatment					<b>MIYOTA</b> CITIZEN WATCH CO., LTD. TOKYO, JAPAN	
Hardness						
Plating						