

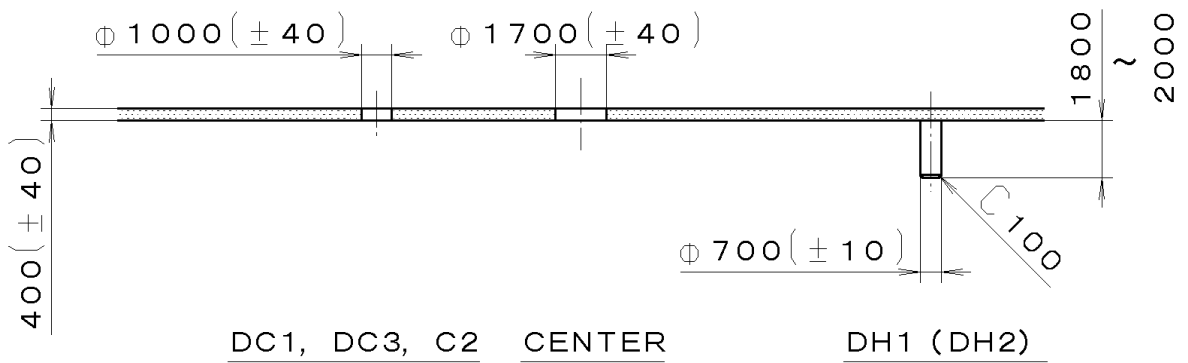

This drawing is provisional and subject to our reconfirmation and/or revision without notice.

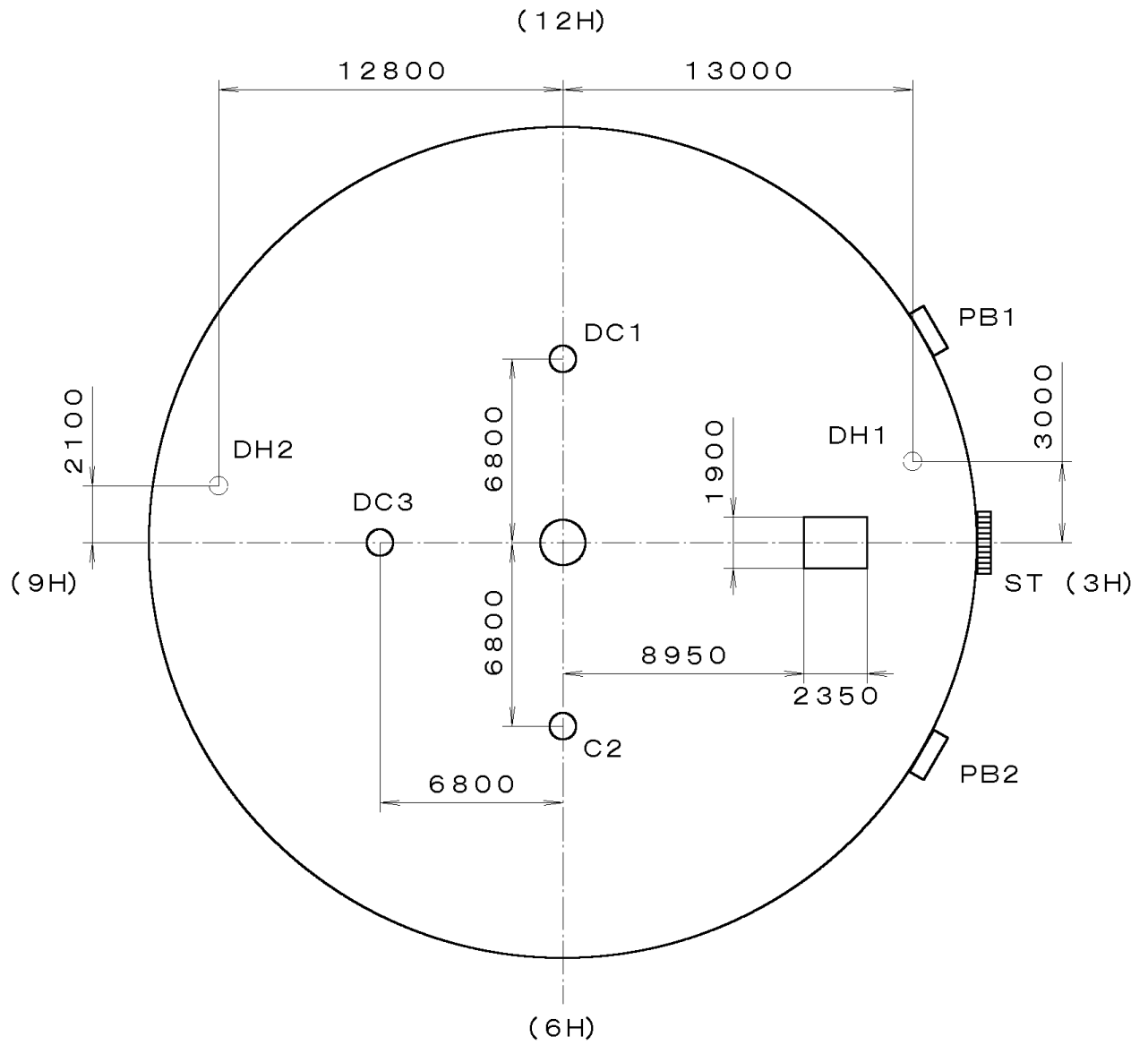

OS10-00A (01) \*\*\* (2100 1121) 00-07-06

7		Quantity		Cal. No. : OS10-00A OS60-00A
6		Unit	1/1000 mm	
5		Scale	4:1	Parts:
4		Date		
3		Drawn		
2		Checked	T. Hiruta	Name:
1		Approved		Indications for Dial
Material				Drawing No. : OS10D000
Heat Treatment		General Tolerances		<b>MIYOTA</b>
Hardness		Dimensions		
Plating		Angles		

This drawing is provisional and subject to our reconfirmation and/or revision without notice.

OS10-00S (01) \*\*\* (2100 1121) 00-07-06 30.5

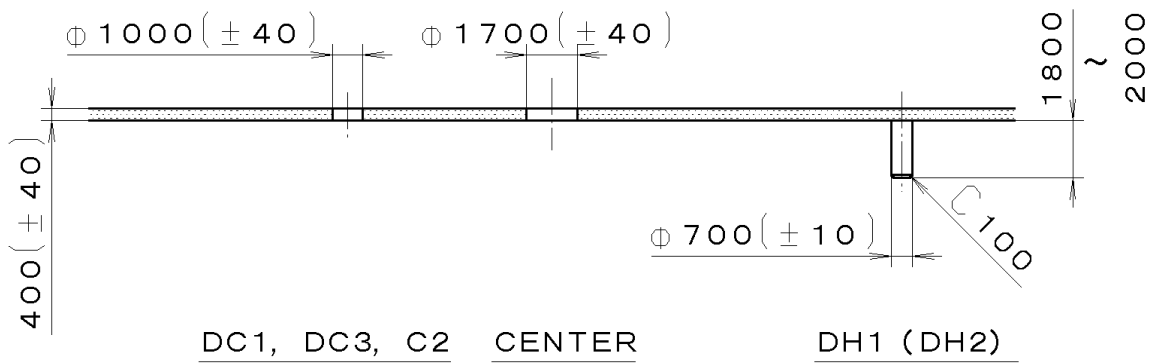
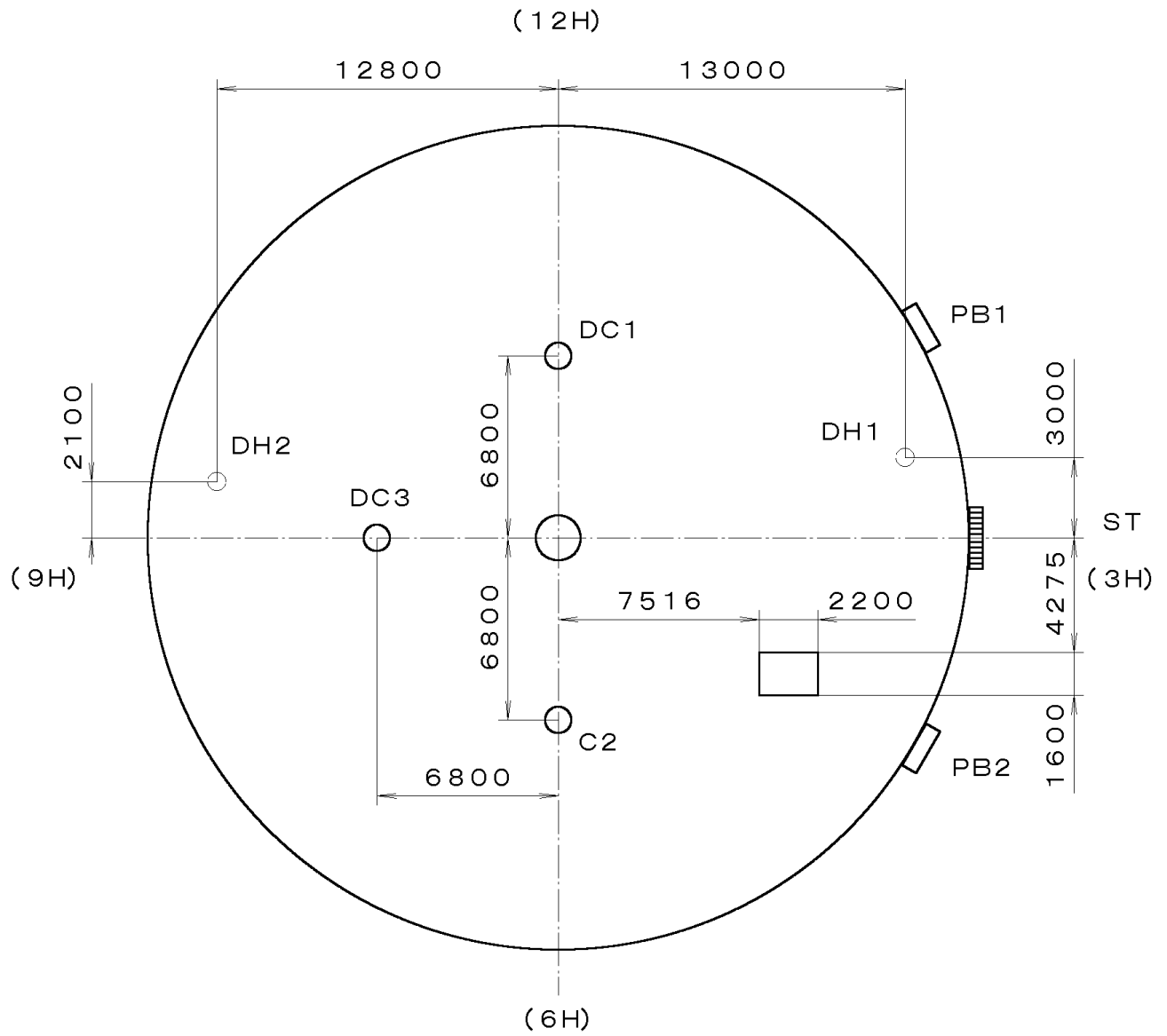

DC1, DC3, C2 CENTER DH1 (DH2)

7		Quantity		Cal. No. : OS10-00S
6		Unit	1/1000 mm	OS60-00S
5		Scale	4:1	Parts:
4		Date		
3		Drawn		Name:
2		Checked	T. Hiruta	
1		Approved		Indications for Dial
Material				Drawing No. : OS10D010
Heat Treatment		General Tolerances		MIYOTA
Hardness		Dimensions		
Plating		Angles		

This drawing is provisional and subject to our reconfirmation and/or revision without notice.

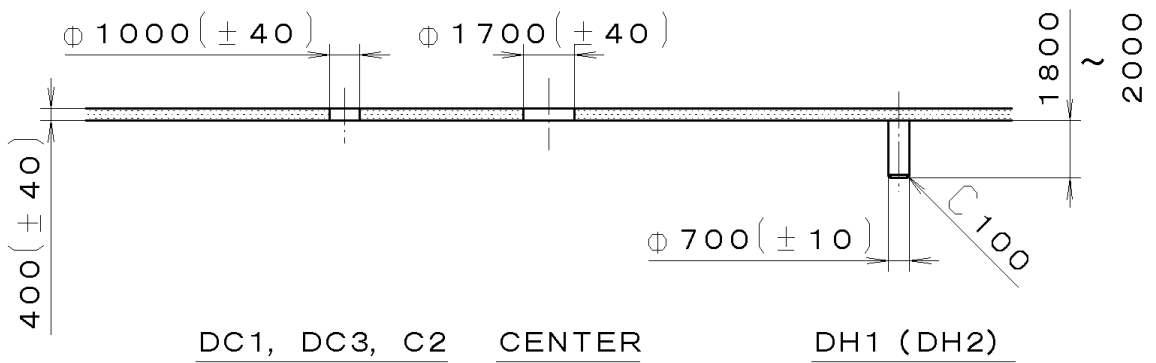
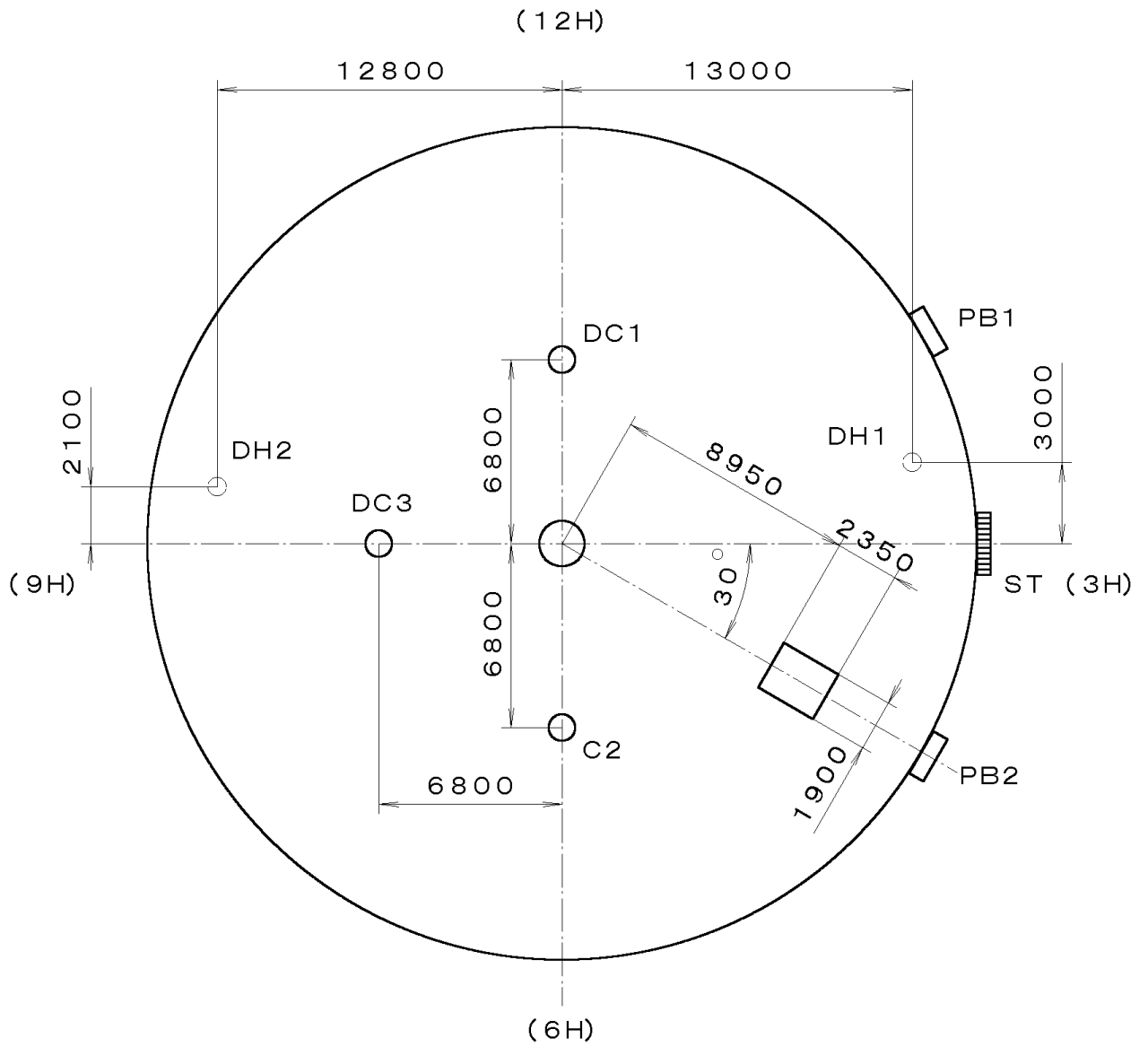

OS10-00U (01) \*\*\* (2100 1121) 00-07-06

7		Quantity		Cal. No. : OS10-00U OS60-00U
6		Unit	1/1000 mm	
5		Scale	4:1	Parts:
4		Date		
3		Drawn		
2		Checked	T. Hiruta	Name:
1		Approved		Indications for Dial
Material				Drawing No. : OS10D020
Heat Treatment		General Tolerances		<b>MIYOTA</b>
Hardness		Dimensions		
Plating		Angles		

This drawing is provisional and subject to our reconfirmation and/or revision without notice.

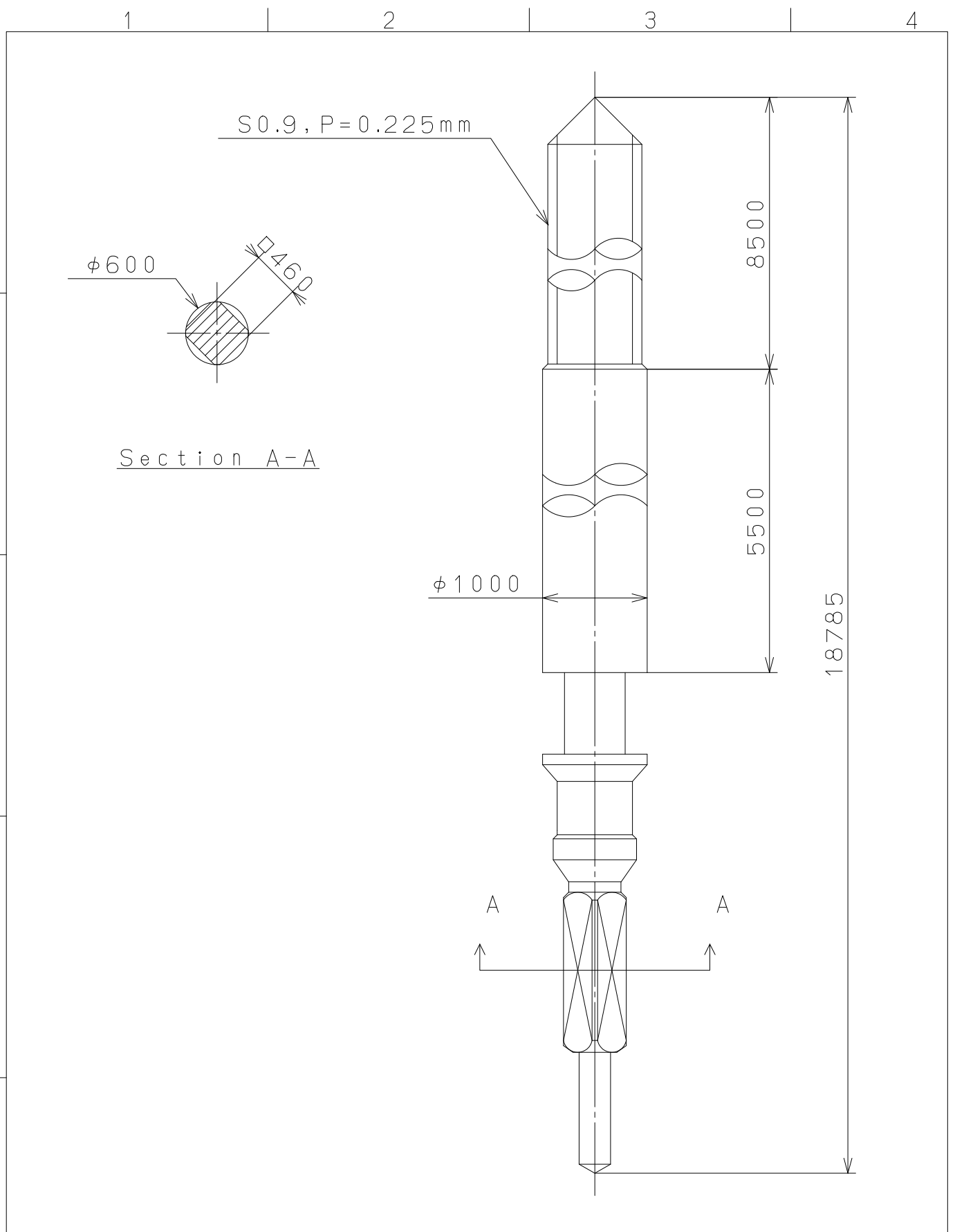

△5			Quantity		Cal.NO.:	
△4			Unit	1 / 1000 mm		
△3			Scale	20 : 1	Parts No.:	
△2			Date		065-453	
△1			Drawn			
Mark	Date	Description	Appro.	Checked	E. Murakami	Name:
Alterations			Approved	SETTING STEM		
Material					Drawing No.: 4530S000	
Heat Treatment					<b>MIYOTA</b> CITIZEN WATCH CO., LTD. TOKYO, JAPAN	
Hardness						
Plating						