

This drawing is provisional and subject to our reconfirmation and/or revision without notice.

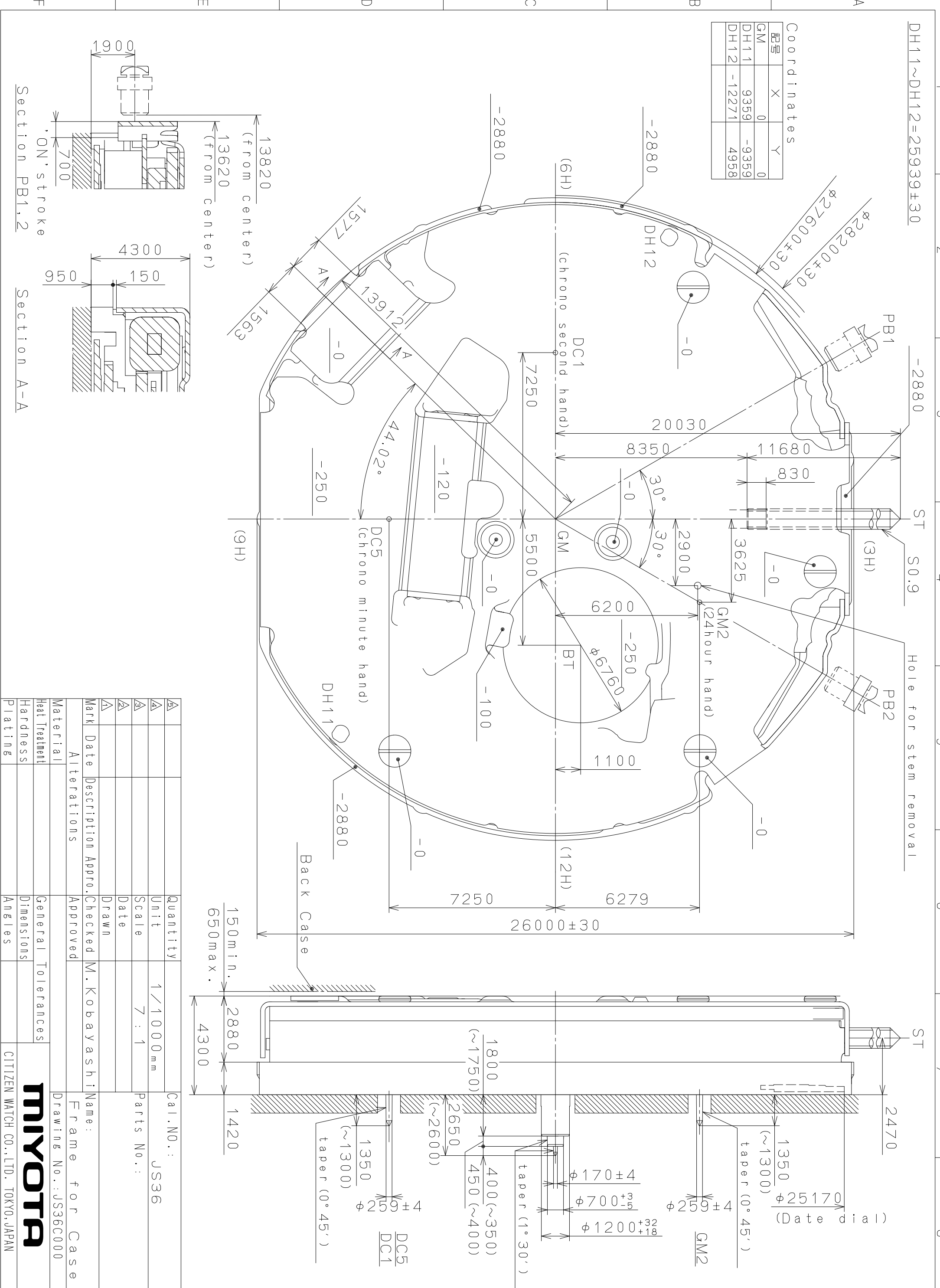

Coordinates

記号	X	Y
GM	0	0
DH11	9359	-9359
DH12	-12271	4958

Section PB1,2

Section A-A

△5	Quantity		Cal. NO.:	JS36
△4	Unit	1/1000 mm	Parts No.:	
△3	Scale	7 : 1	Name:	Frame for Case
△2	Date		Drawing No.:	JS36C000
△1	Drawn			
Mark	Date	Description	Appro.	Checked
			M. Kobayashi	
Alterations		Approved		
Material	General Tolerances			
Heat Treatment	Dimensions			
Hardness	Angles			
Plating	CITIZEN WATCH CO., LTD. TOKYO, JAPAN			

MIYOTA

This drawing is provisional and subject to our reconfirmation and/or revision without notice.

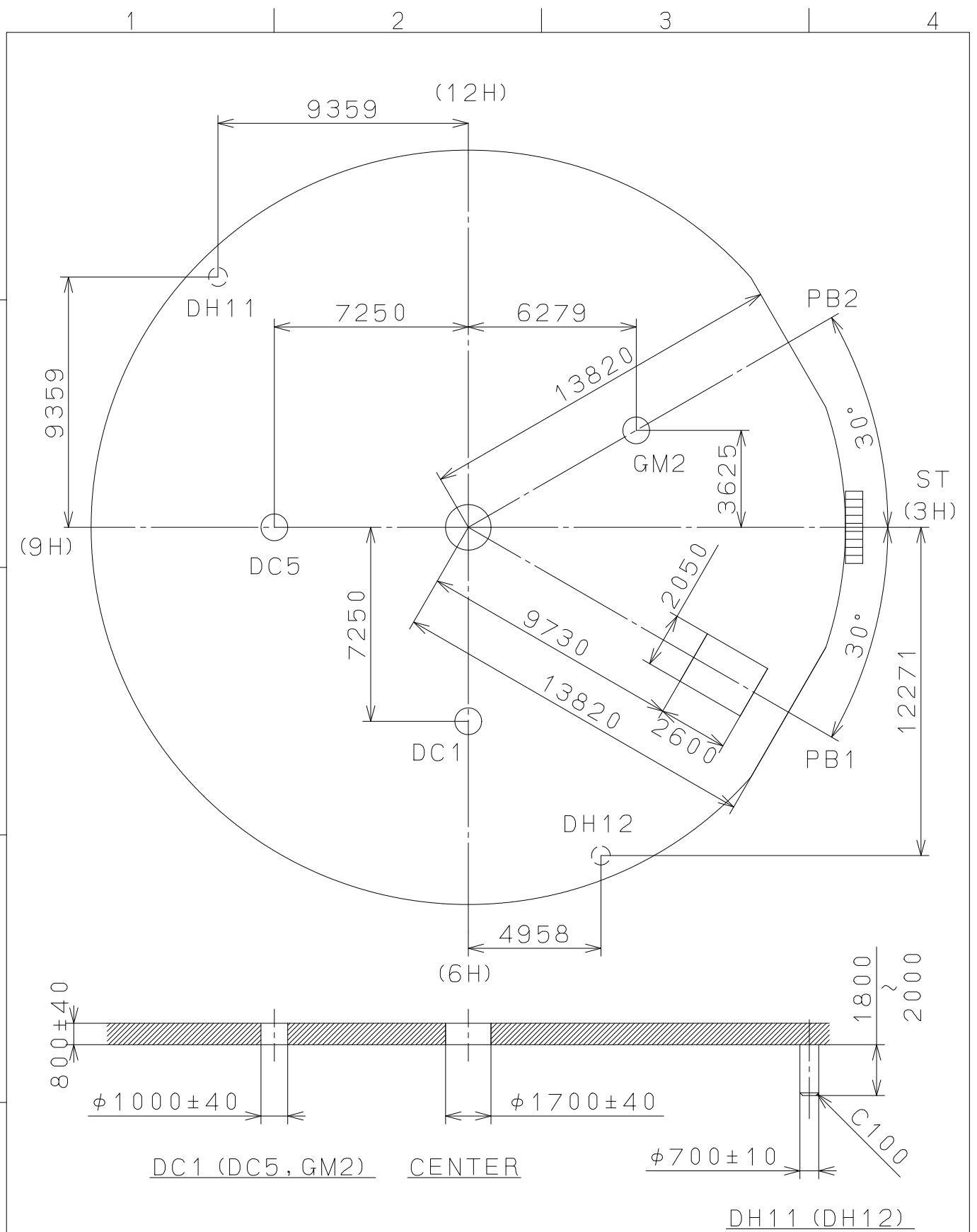

△			Quantity		Cal.NO.:
△			Unit	1/1000 _{mm}	JS36-00C
△			Scale	5 : 1	Parts No.:
△			Date		
△			Drawn		
Mark	Date	Description	Appr.	Checked	M. Kobayashi
Alterations			Approved	Name:	
Material					Indications for Dial
Heat Treatment					Drawing No.: JS36D000
Hardness					MIYOTA
Plating					

2006/12/25 (07:50:10)

This drawing is provisional and subject to our reconfirmation and/or revision without notice.

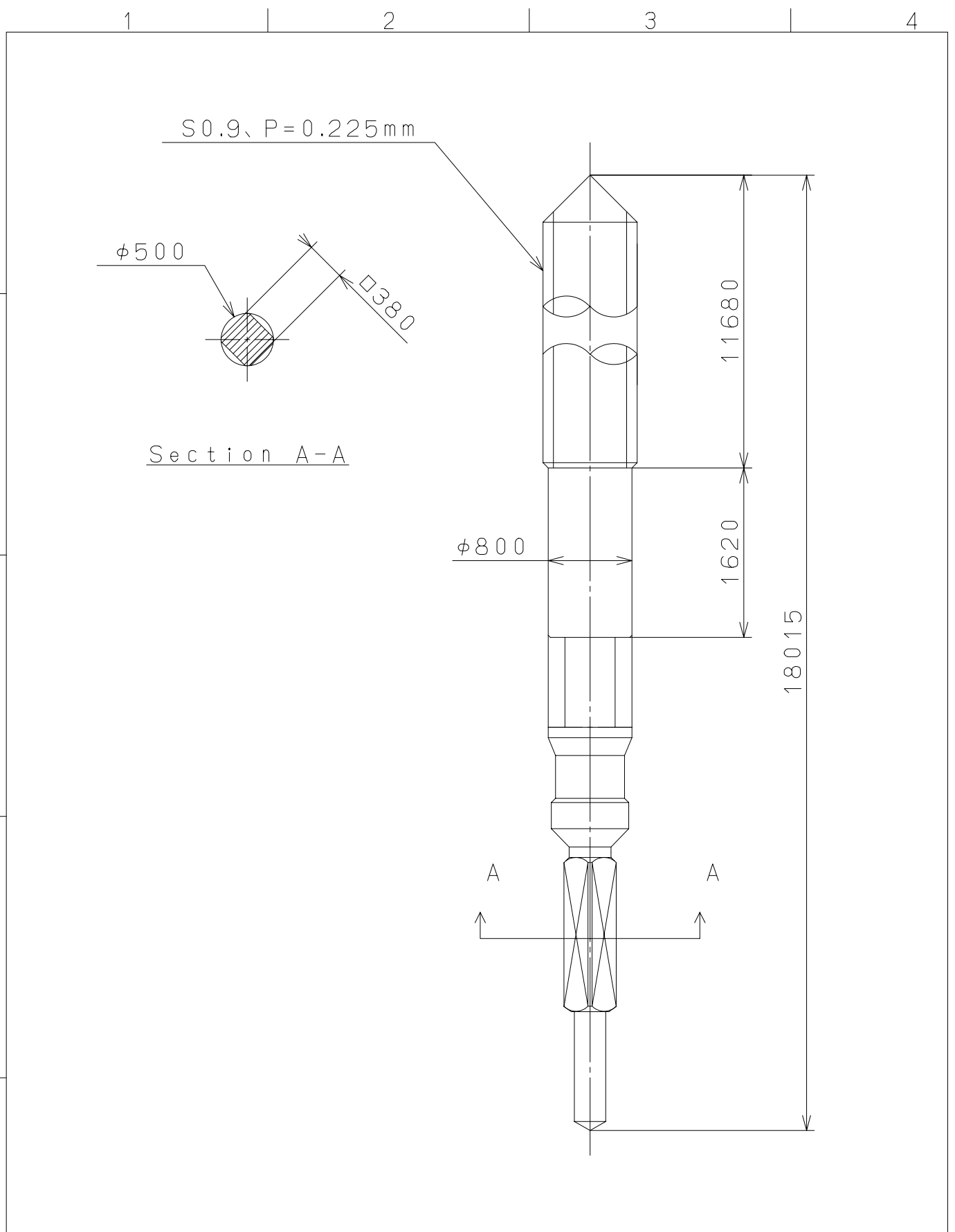

⑤			Quantity		Cal.NO.:
④			Unit	1 / 1000 mm	
③			Scale	20 / 1	Parts No.:
②			Date		065-505
①			Drawn		Name:
Mark	Date	Description	Appr.	Checked	T.Hiruta
Alterations			Approved	SETTING STEM	
Material				Drawing No.: 5050S000	
Heat Treatment				General Tolerances	
Hardness				Dimensions	
Plating				Angles	
				MIYOTA	
				CITIZEN WATCH CO., LTD. TOKYO, JAPAN	