

This drawing is provisional and subject to our reconfirmation and/or revision without notice.

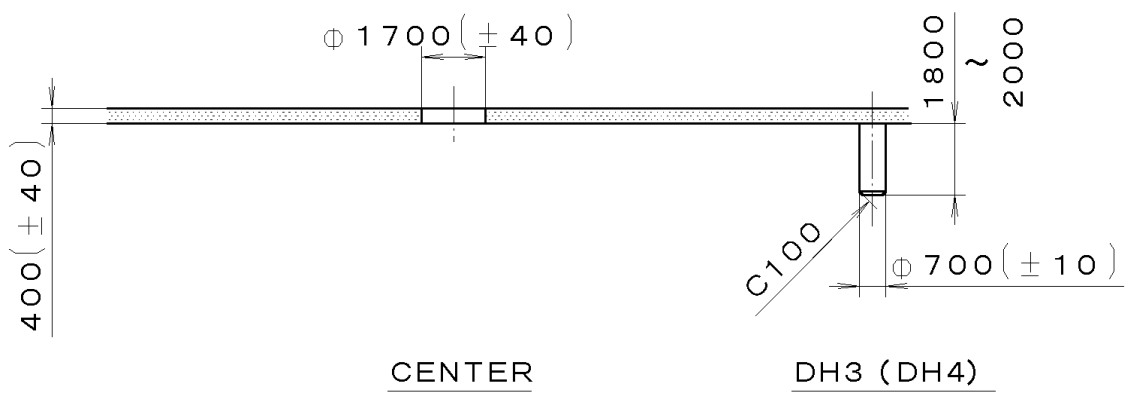
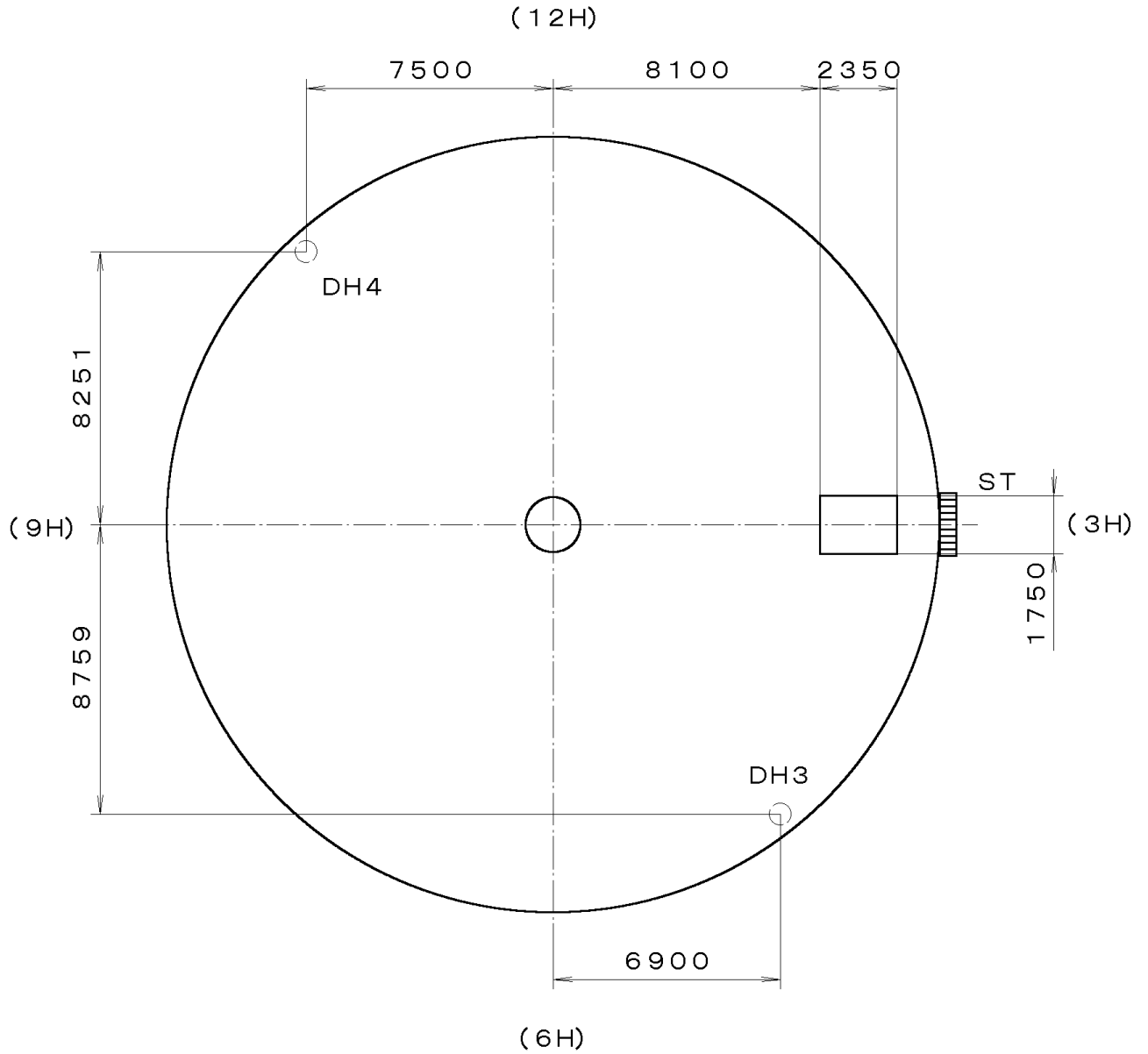

\*\*\* T I P W 2S60-00A (01) \*\*\* (2100 1121) 00-06-29

7			Quantity		Cal. No. :	2S60-00A
6			Unit	1/1000 mm	Parts:	
5			Scale	5:1	Name:	Indications for Dial
4			Date		Drawing No. : 2S60D000	
3			Drawn			
2			Checked	T. Hiruta		
1			Approved			
Material			General Tolerances			
Heat Treatment			Dimensions			
Hardness			Angles			
Plating						

This drawing is provisional and subject to our reconfirmation and/or revision without notice.

00-06-29 ) (2100 1121 ) (01) \*\*\* 2S60-00U \*\*\* TIPW

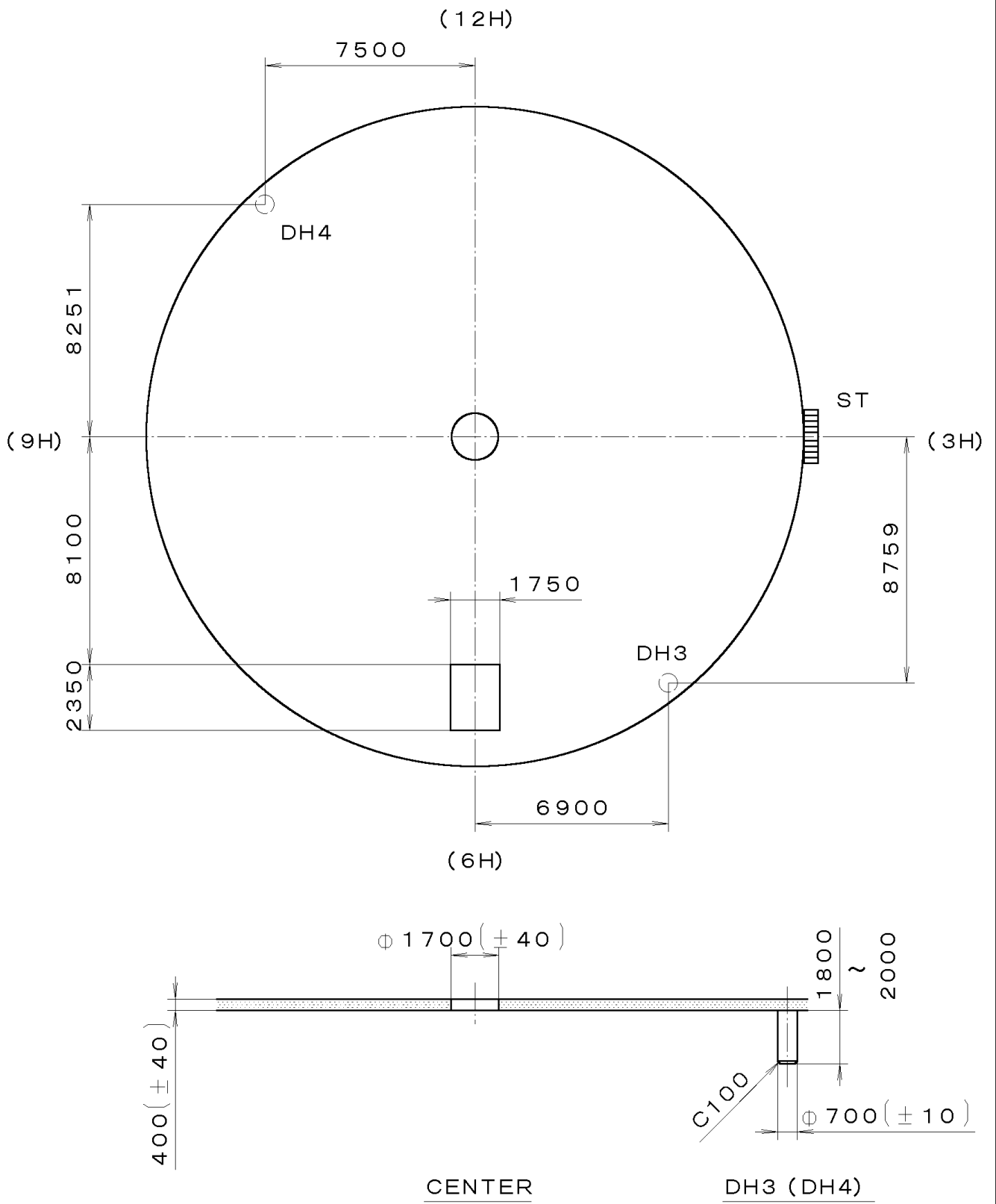

7			Quantity		Cal. No. :	2S60-00U
6			Unit	1/1000 mm	Parts:	
5			Scale	5:1	Name:	Indications for Dial
4			Date		Drawing No. : 2S60D010	
3			Drawn			
2			Checked	T. Hiruta		
1			Approved			
Material						
Heat Treatment			General Tolerances			
Hardness			Dimensions			
Plating			Angles			