

This drawing is provisional and subject to our reconfirmation and/or revision without notice.

Coordinates			
Mark	X	Y	R
GM	0	0	—
DH1	-15200	-5300	—
DH2	15200	5300	—
b1	3092	16654	320
b2	-16920	800	320
b3	-16920	-800	320
b4	-800	-16920	320
b5	800	-16920	320
b6	16920	-800	320
b7	16920	800	320

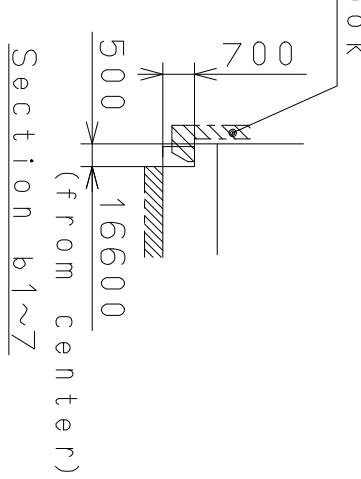
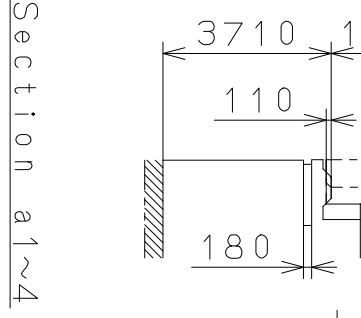
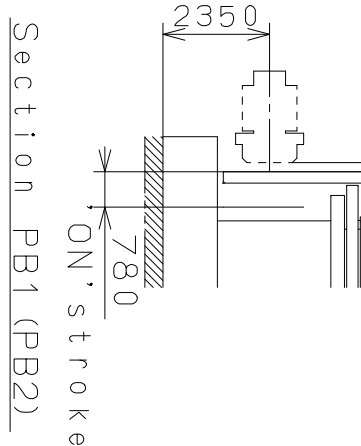
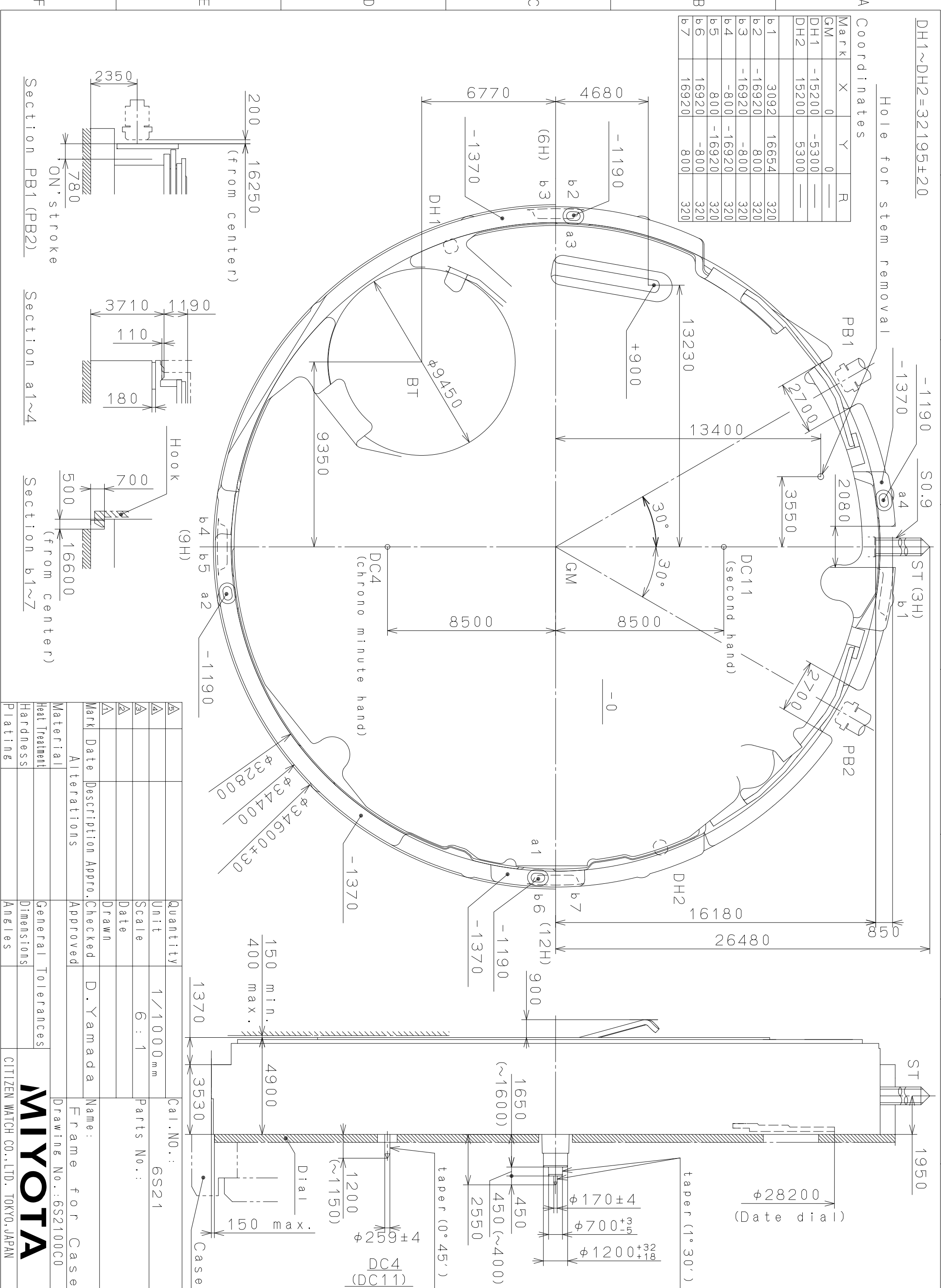

Mark	Date	Description	Appr.	Checked	Drawn	Name:
Alterations			Approved			D. Yamada
Material						Frame for Case
Heat Treatment						Drawing No.: 6S2100C0
Hardness						
Plating						

Quantity	Unit	Cal. NO.:
1	1/1000 mm	6S21
Scale	6 : 1	Parts No.:

MİYOTA
CITIZEN WATCH CO., LTD. TOKYO, JAPAN

This drawing is provisional and subject to our reconfirmation and/or revision without notice.

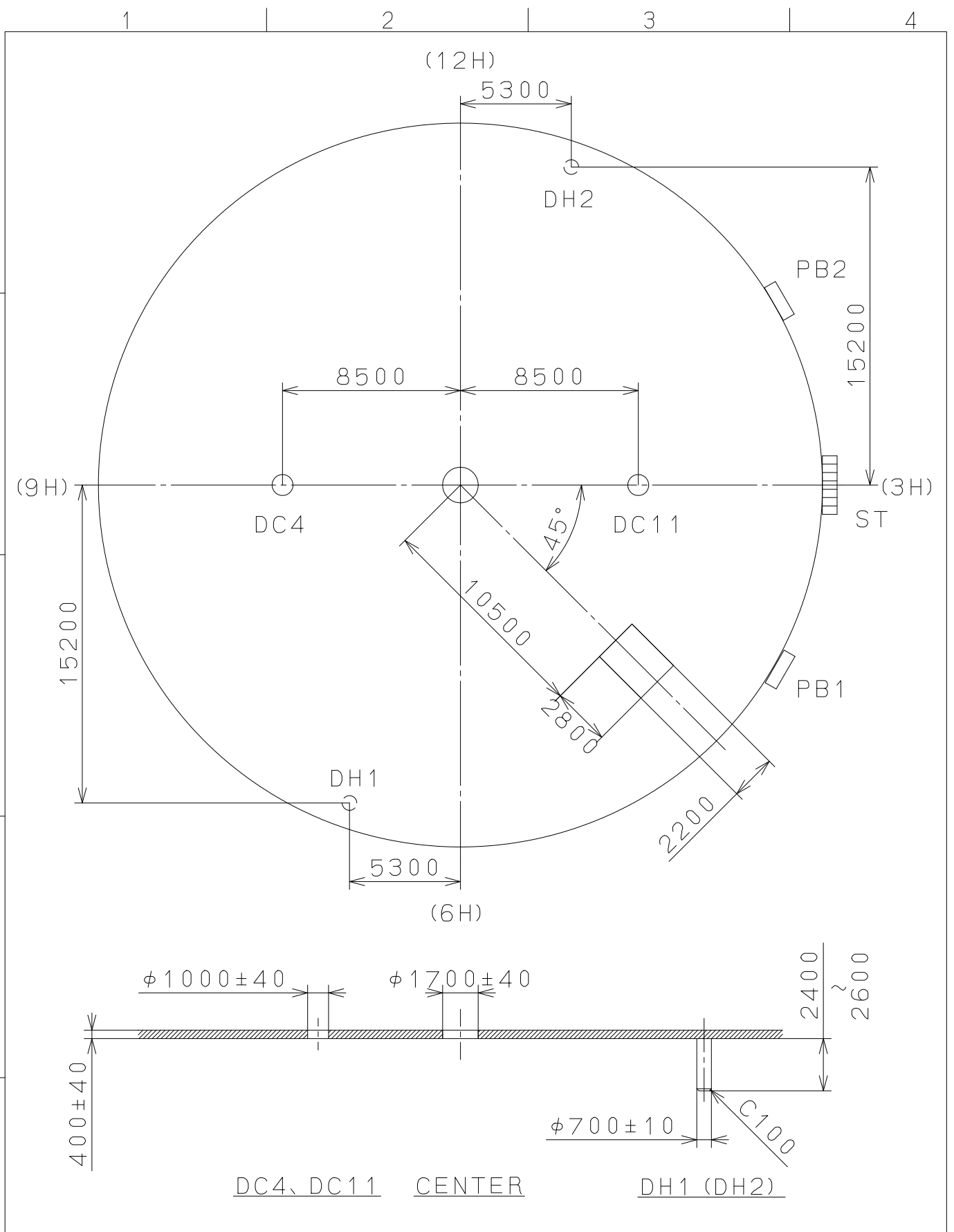

△			Quantity		Cal.NO.:
△			Unit	1 / 1000 _{mm}	6S21-00A
△			Scale	4 : 1	Parts No.:
△			Date		
△			Drawn		
Mark	Date	Description	Appr.	Checked	Name:
		Alterations	Approved	D. Yamada	Indications for Dial
Material					Drawing No.: 6S2100D0
Heat Treatment			General Tolerances	MIYOTA CITIZEN WATCH CO., LTD. TOKYO, JAPAN	
Hardness			Dimensions		
Plating			Angles		

This drawing is provisional and subject to our reconfirmation and/or revision without notice.

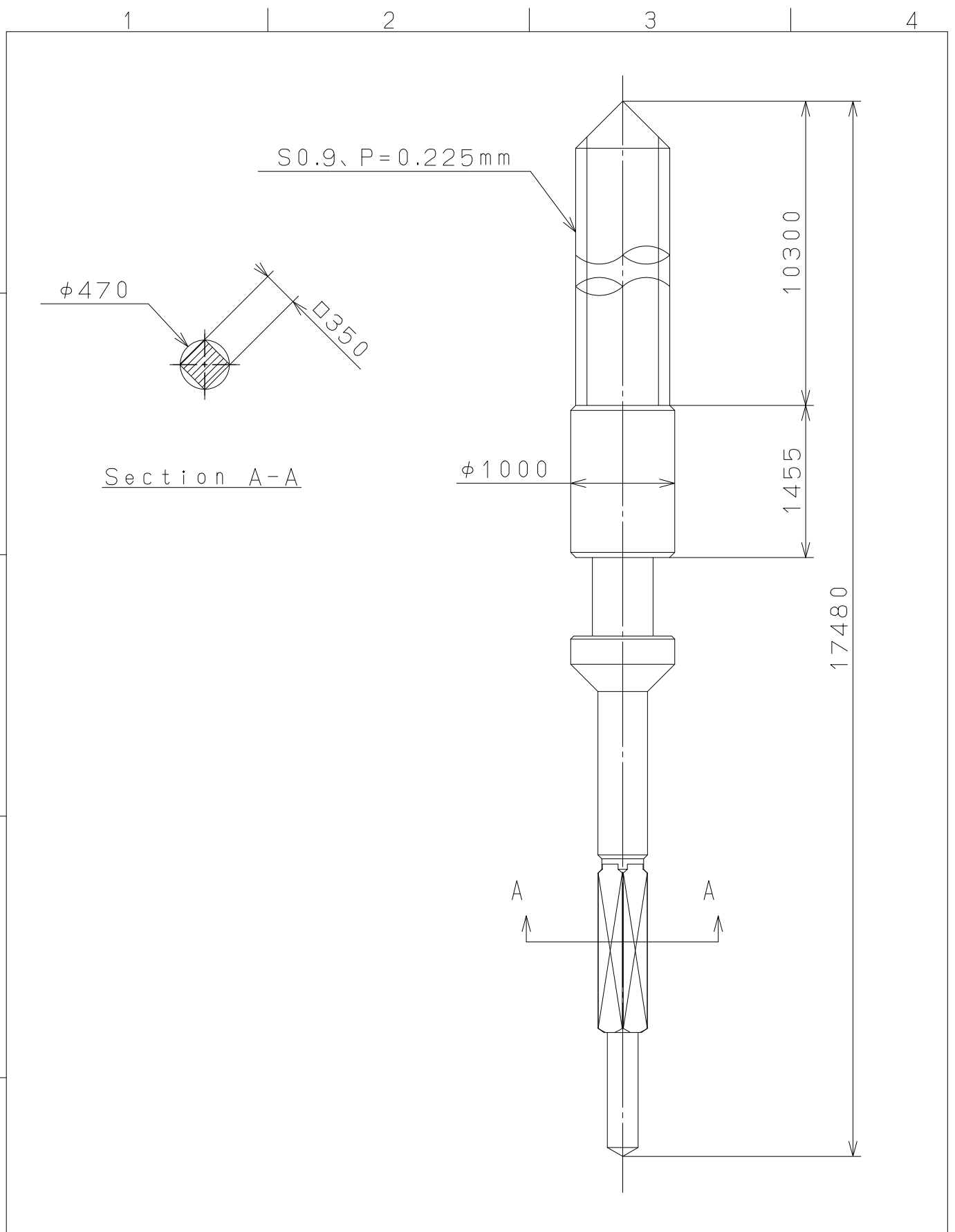

△			Quantity		Cal.NO.:
△			Unit	1 / 1000 mm	
△			Scale	20 : 1	Parts No.:
△			Date		065-A13
△			Drawn		
Mark	Date	Description	Appro.	Checked	Name:
		Alterations		Approved	SETTING STEM
Material					Drawing No.: A13000S0
Heat Treatment				General Tolerances	MIYOTA
Hardness				Dimensions	
Plating				Angles	
					CITIZEN WATCH CO., LTD. TOKYO, JAPAN