

This drawing is provisional and subject to our reconfirmation and/or revision without notice.

DH1~DH2=16171±20

Coordinates			
Mark	X	Y	R
GM	0	0	—
h1	7270	4825	350
h2	-7270	4825	350
h3	-7270	-4825	350
h4	7557	-4025	325
DH1	-7900	-3000	—
DH2	8234	-1900	—
a1	2793	7550	500
a2	6600	5539	300
a3	7200	4787	300
a4	8299	3350	300
a5	8800	1632	300
a6	8800	-1632	300
a7	8299	-3350	300
a8	7200	-4787	300
a9	6600	-5539	300
a10	2793	-7550	500
a11	-2793	-7550	500
a12	-6600	-5539	300
a13	-7200	-4787	300
a14	-8299	-3350	300
a15	-8800	-1632	300
a16	-8800	1632	300
a17	-8299	3350	300
a18	-7200	4787	300
a19	-6600	5539	300
a20	-2793	7550	500
f21	5788	7505	1600
f22	5788	-7505	1600
f23	-5788	-7505	1600
f24	-6864	6800	1600

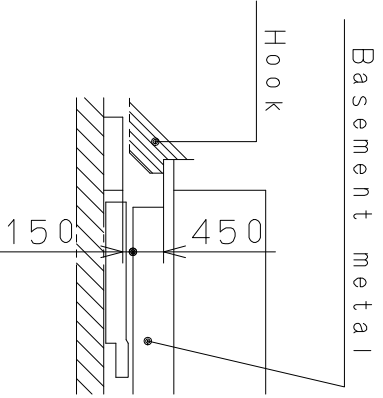
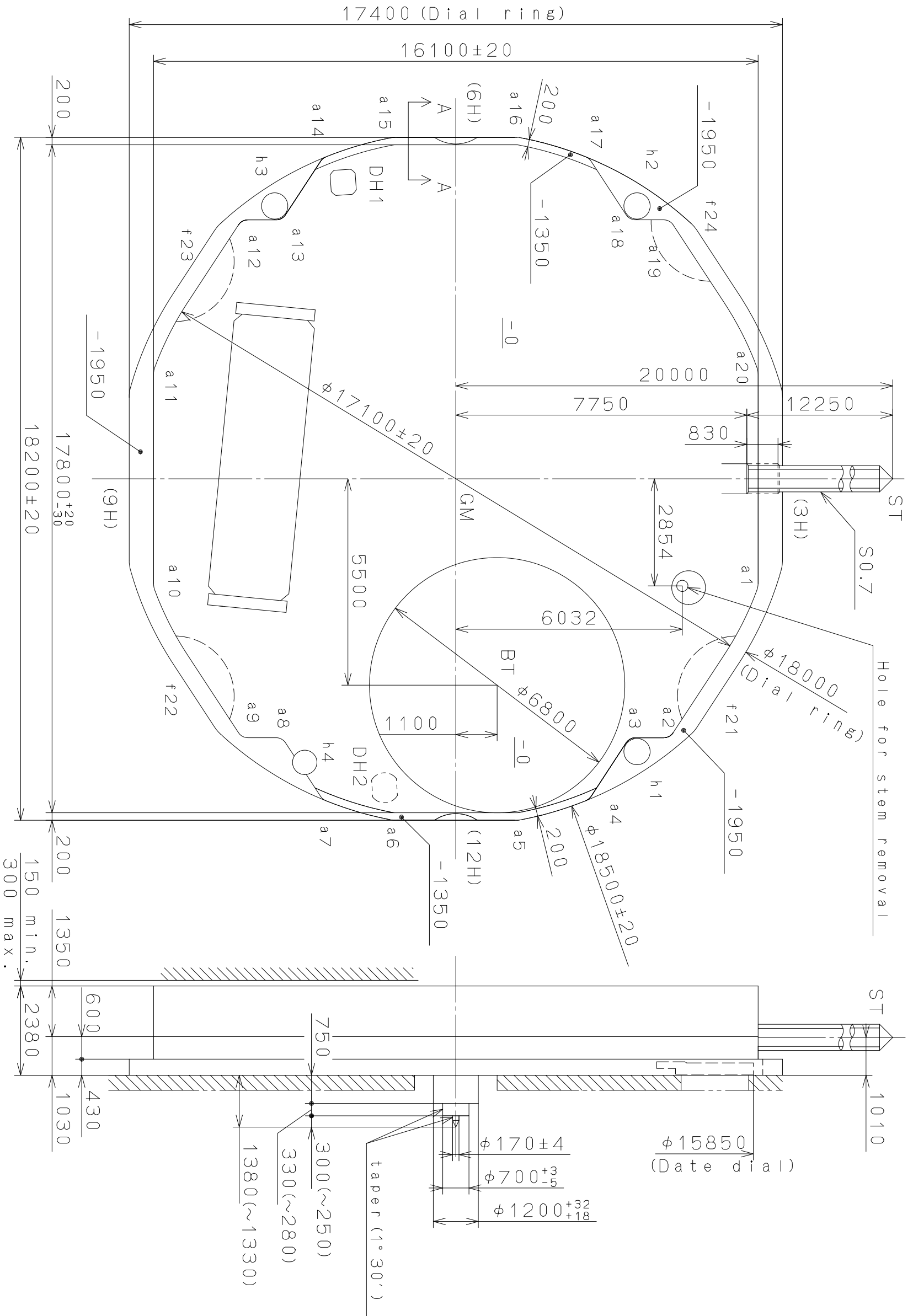

Section f21~f24

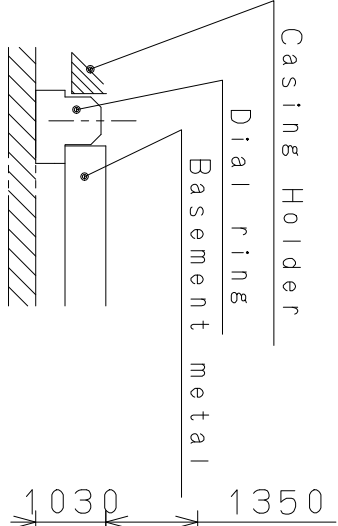

Section h1~h4

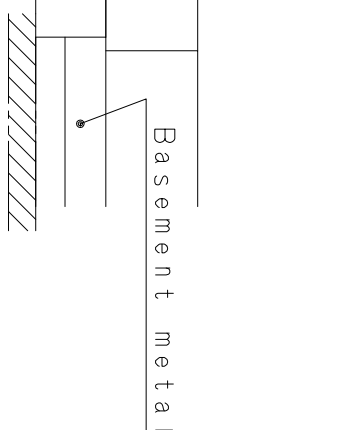

Section A-A

Material	Alterations	Quantity	Unit	Cal. NO.:
Heat Treatment	Date	1 / 1000	mm	9T12
Hardness	Description	Scale	9 : 1	Parts No.:
Plating	Checked	Drawn	Approved	Name:
	Approved	Frame for Case		Drawing No.: 9T1200C0
General Tolerances		MIYOTA		
Dimensions		CITIZEN WATCH CO., LTD. TOKYO, JAPAN		
Angles				

This drawing is provisional and subject to our reconfirmation and/or revision without notice.

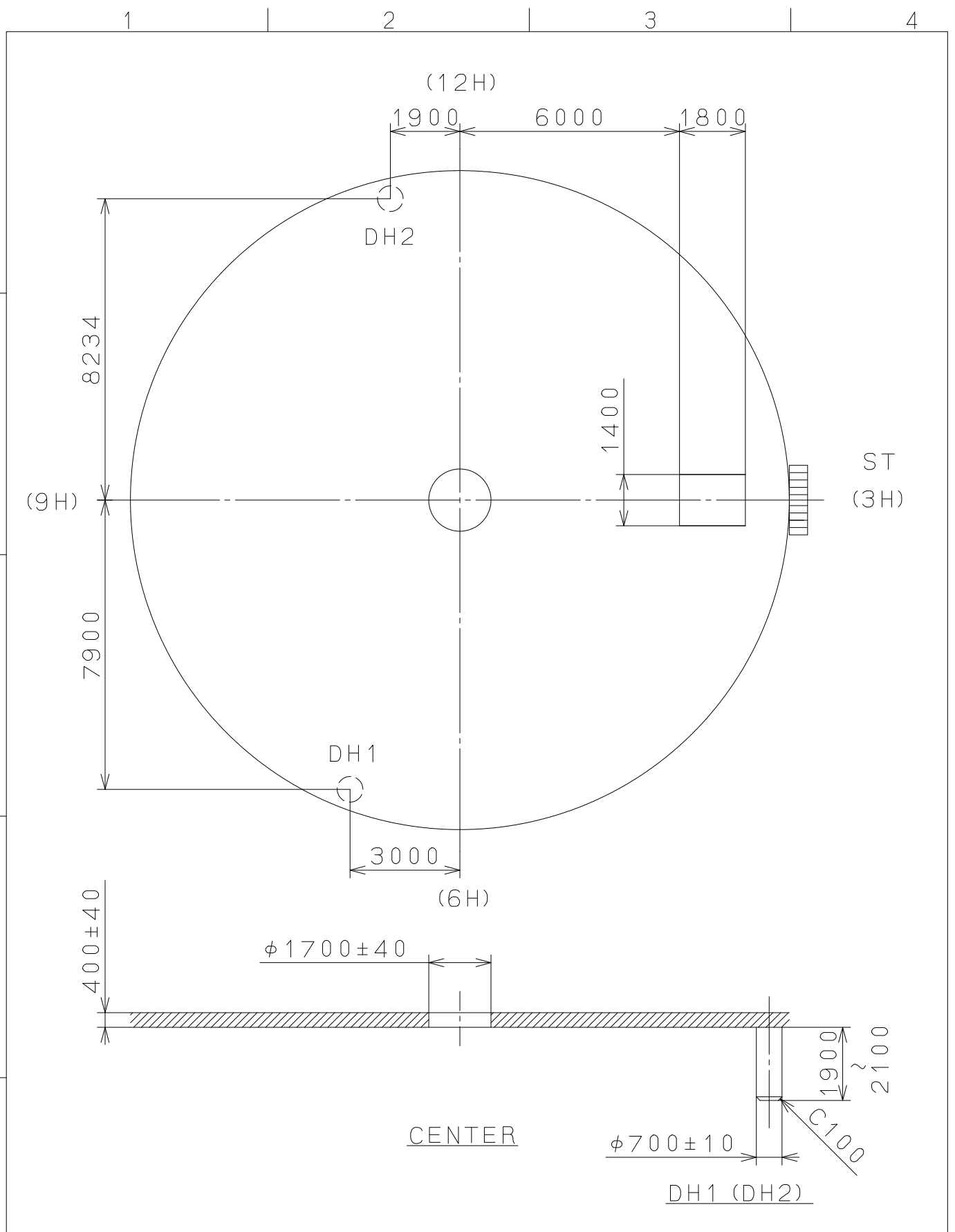

△			Quantity		Cal.NO.:
△			Unit	1 / 1000 mm	9T12-00A
△			Scale	7 : 1	Parts No.:
△			Date		
△			Drawn		
Mark	Date	Description	Appr.	Checked	Name:
Alterations			Approved		Indications for Dial
Material					Drawing No.: 9T1200D0
Heat Treatment					MIYOTA
Hardness					
Plating					
					CITIZEN WATCH CO., LTD. TOKYO, JAPAN

This drawing is provisional and subject to our reconfirmation and/or revision without notice.

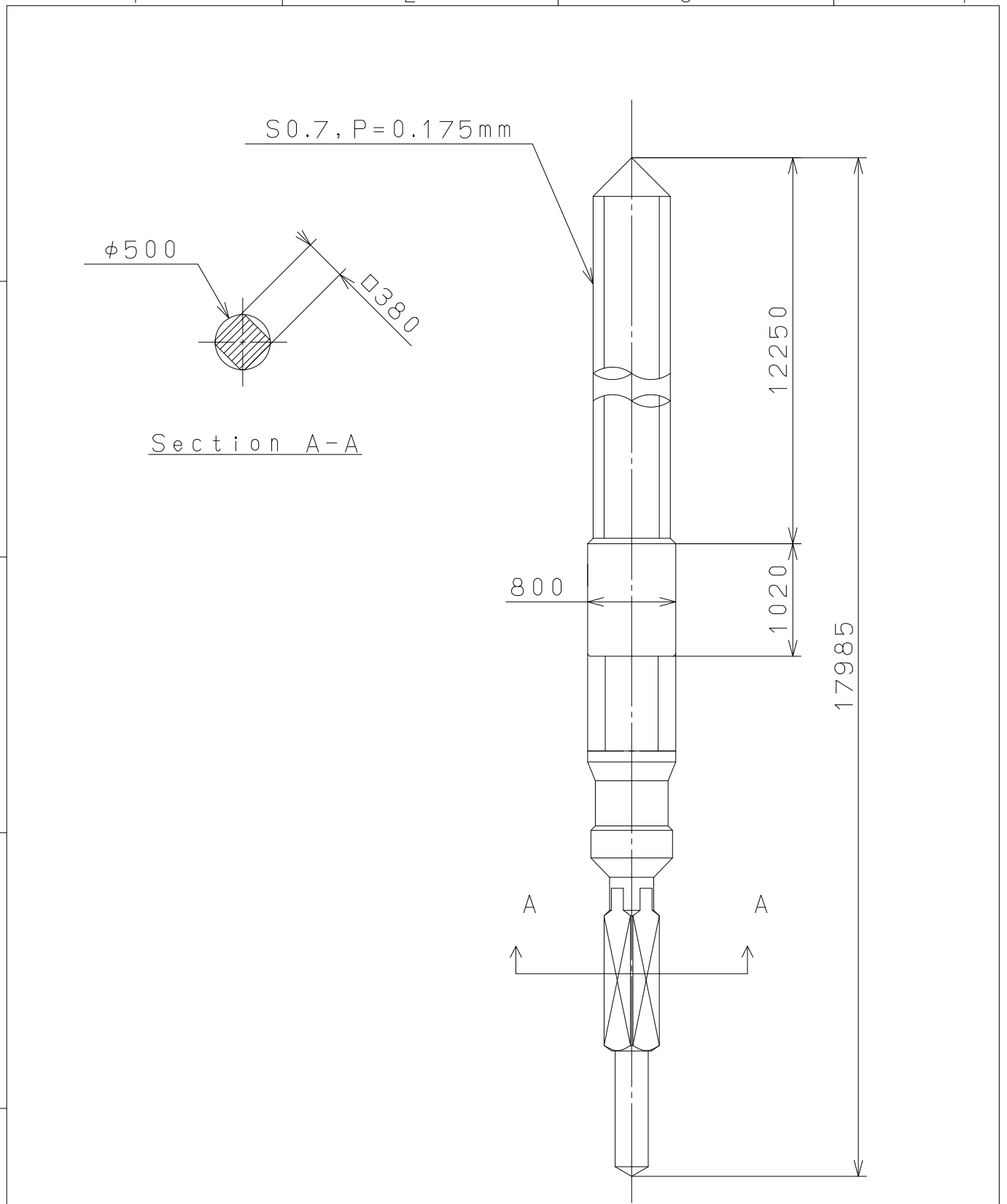

△5			Quantity		Cal.NO.:
△4			Unit	1/1000mm	
△3			Scale	20:1	Parts No.:
△2			Date		065-495
△1			Drawn		
Mark	Date	Description	Appro.	Checked	Name:
		Alterations		Approved	SETTING STEM
Material					Drawing No.:495000S0
Heat Treatment			General	Tolerances	MIYOTA
Hardness			Dimensions		
Plating			Angles		
					CITIZEN WATCH CO.,LTD. TOKYO,JAPAN