

This drawing is provisional and subject to our reconfirmation and/or revision without notice.

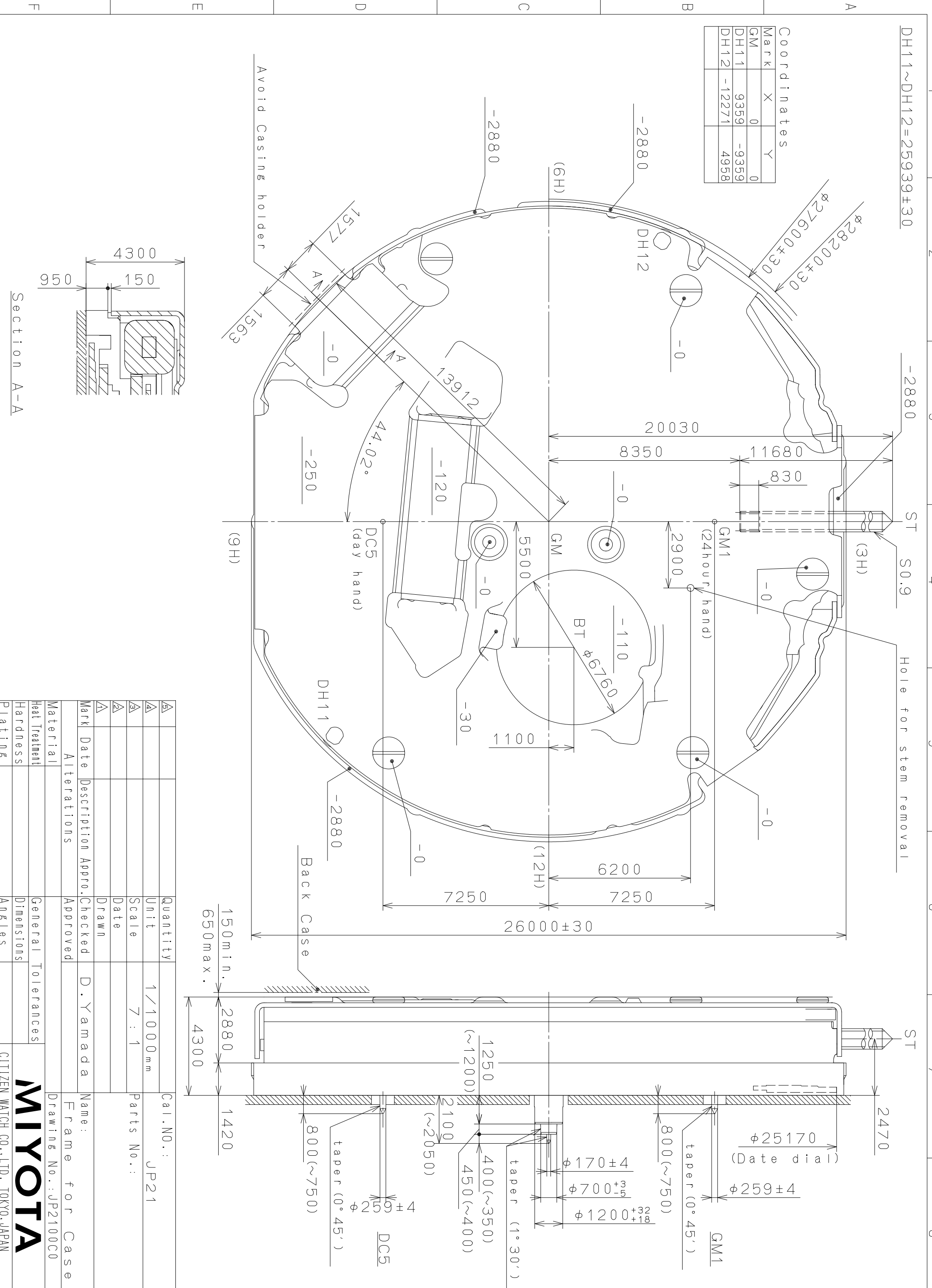

Coordinates

Mark	X	Y
GM	0	0
DH11	9359	-9359
DH12	-12271	4958

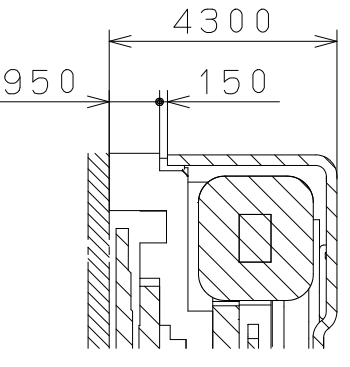

Section A-A

Quantity	Unit	1/1000 mm	Cal. NO.:	JP21
Scale	Date	7:1	Parts No.:	
Material	Date		Drawn	
Heat Treatment	Date		Checked	
Hardness	Date		Appro.	
Plating	Date		Checked	
Alterations			Approved	D. Yamada
Material			Name: Frame for Case	
Heat Treatment			Drawing No.: JP2100C0	
Hardness			General Tolerances	
Plating			Dimensions	
			Angles	

MIYOTA
CITIZEN WATCH CO., LTD. TOKYO, JAPAN

This drawing is provisional and subject to our reconfirmation and/or revision without notice.

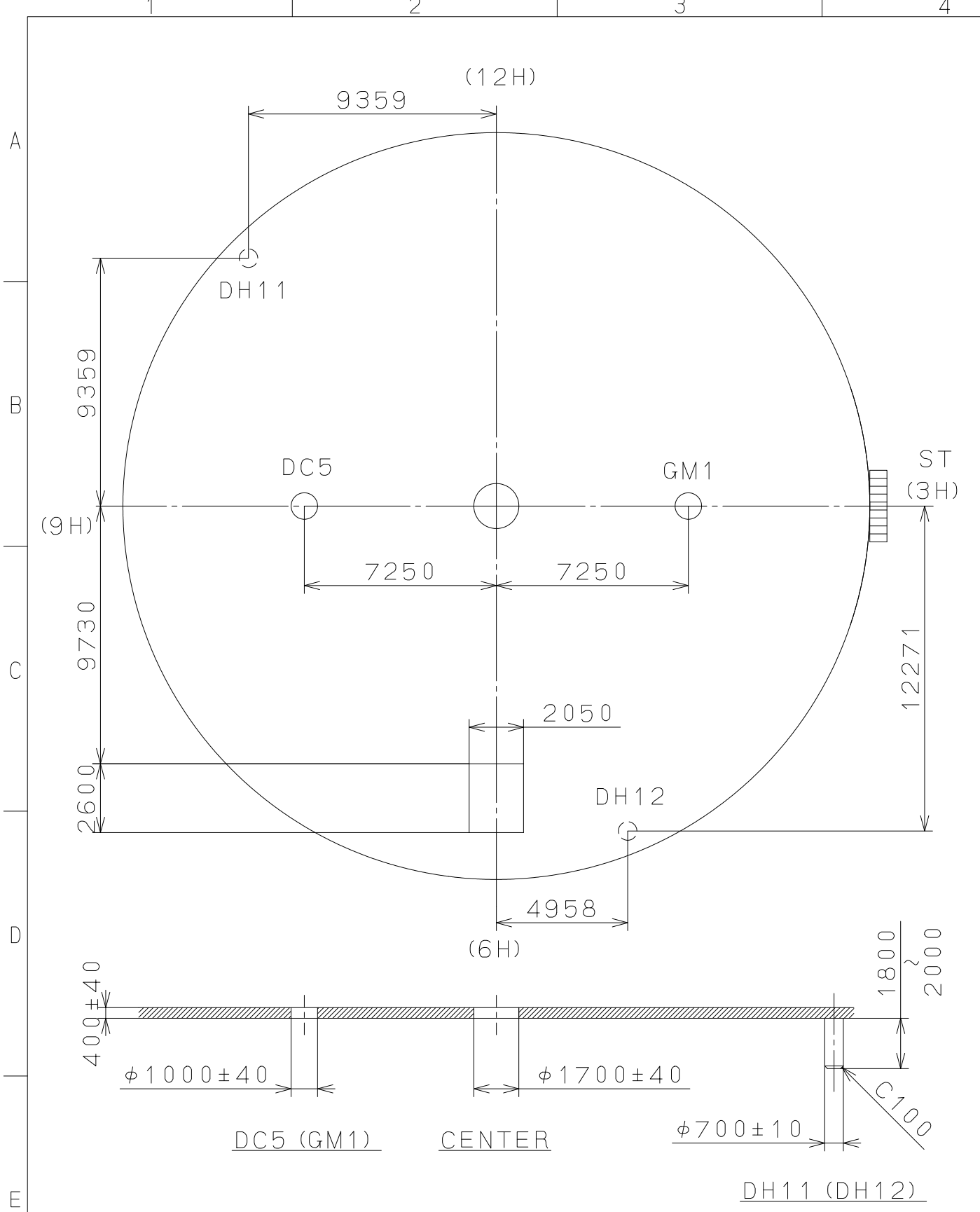

△			Quantity		Cal.NO.:
△			Unit	1 / 1000 _{mm}	JP21-00C
△			Scale	5 : 1	Parts No.:
△			Date		
△			Drawn		
Mark	Date	Description	Appro.	Checked	Name:
		Alterations		Approved	D. Yamada
Material					Indications for Dial
Heat Treatment					Drawing No.: JP2100D0
Hardness					MIYOTA
Plating					

This drawing is provisional and subject to our reconfirmation and/or revision without notice.

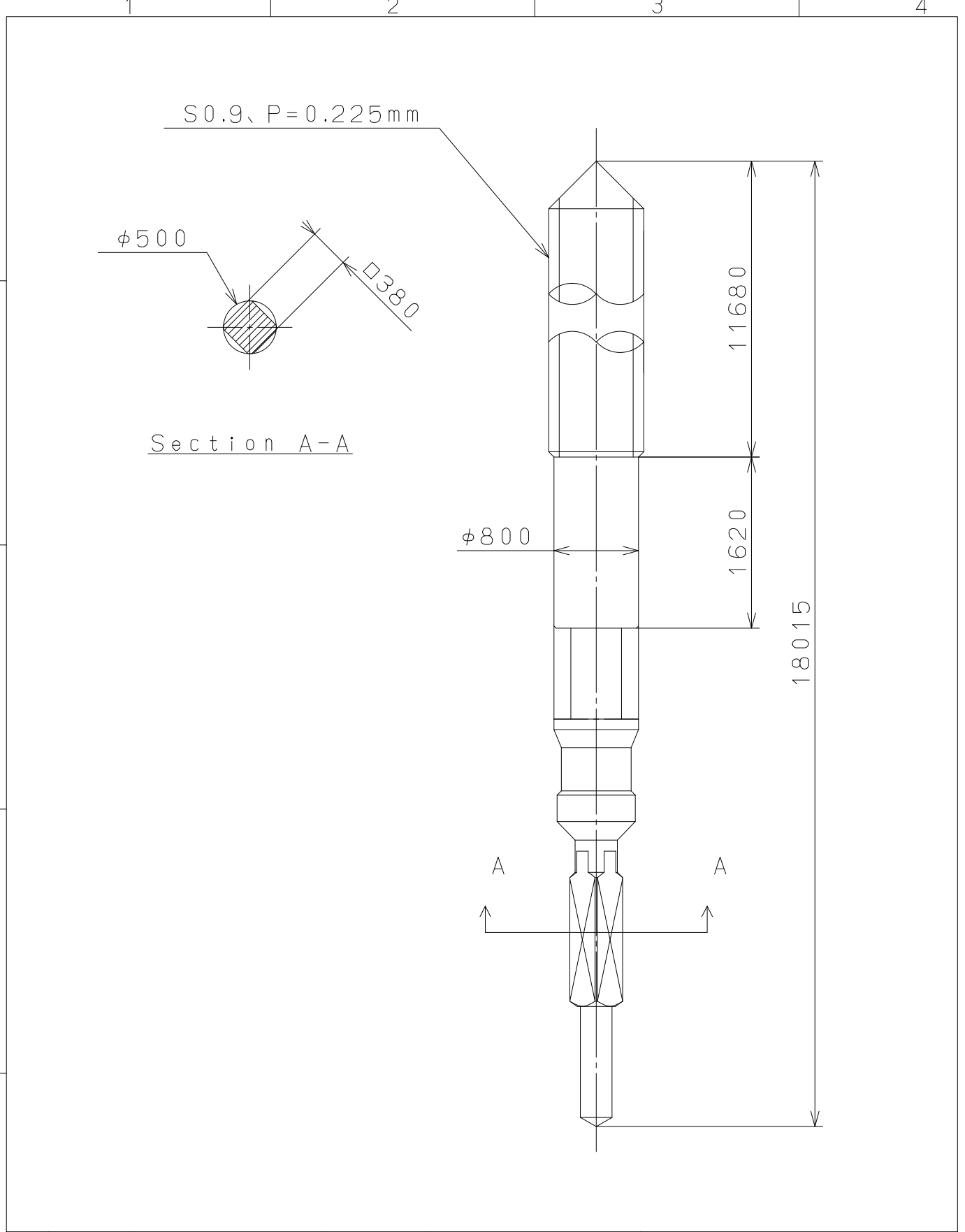

⑤			Quantity		Cal.NO.:
④			Unit	1 / 1000 mm	
③			Scale	20 : 1	Parts No.:
②			Date		065-505
①			Drawn		
Mark	Date	Description	Appro.	Checked	D. Yamada
Alterations			Approved	Name: SETTING STEM	
Material					Drawing No.: 505000S0
Heat Treatment					MIYOTA
Hardness					
Plating					
					CITIZEN WATCH CO., LTD. TOKYO, JAPAN