

This drawing is provisional and subject to our reconfirmation and/or revision without notice.

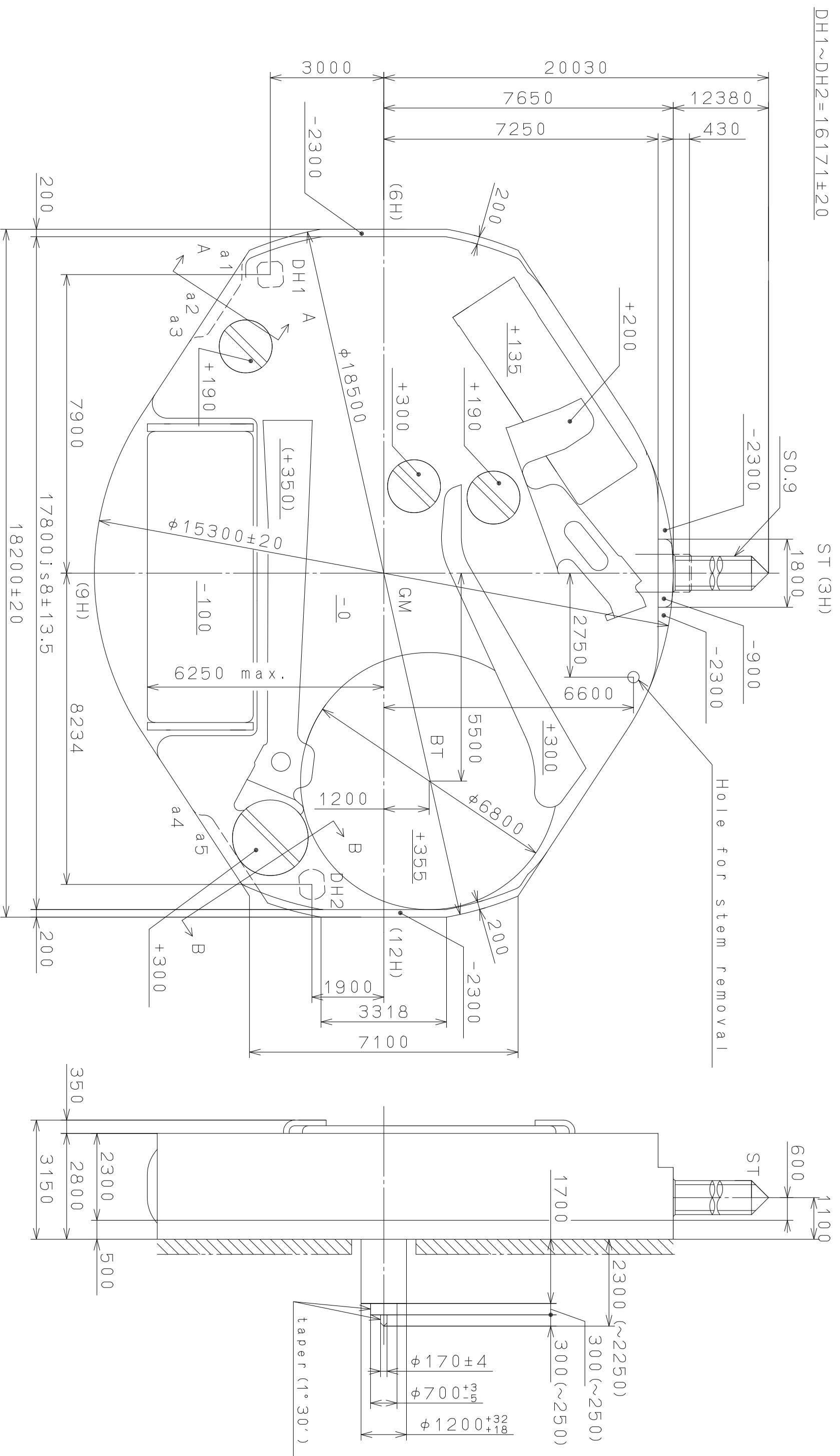

Coordinates

Mark	X	Y	R
GM	0	0	—
a1	-7838	-4250	500
a2	-6550	-4855	300
a3	-5951	-4888	300
a4	6101	-4790	300
a5	6700	-4756	300

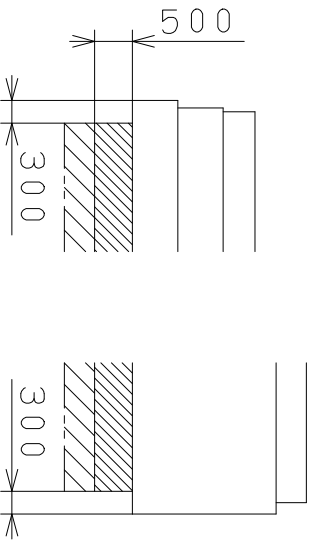

Section A-A

Section B-B

△	Quantity	1/1000 mm	Cal. NO.:	2039
△	Unit	Scale	Parts No.:	
△	Scale	Date		
△	Date	Drawn		
△	Description	Checked	D. Yamada	Name:
△	Alteraions	Approved		Frame for Case
△	Material			Drawing No.: 203900C0
△	Heat Treatment	General Tolerances		
△	Hardness	Dimensions		
△	Plating	Angles		

MIYOTA
CITIZEN WATCH CO., LTD. TOKYO, JAPAN

This drawing is provisional and subject to our reconfirmation and/or revision without notice.

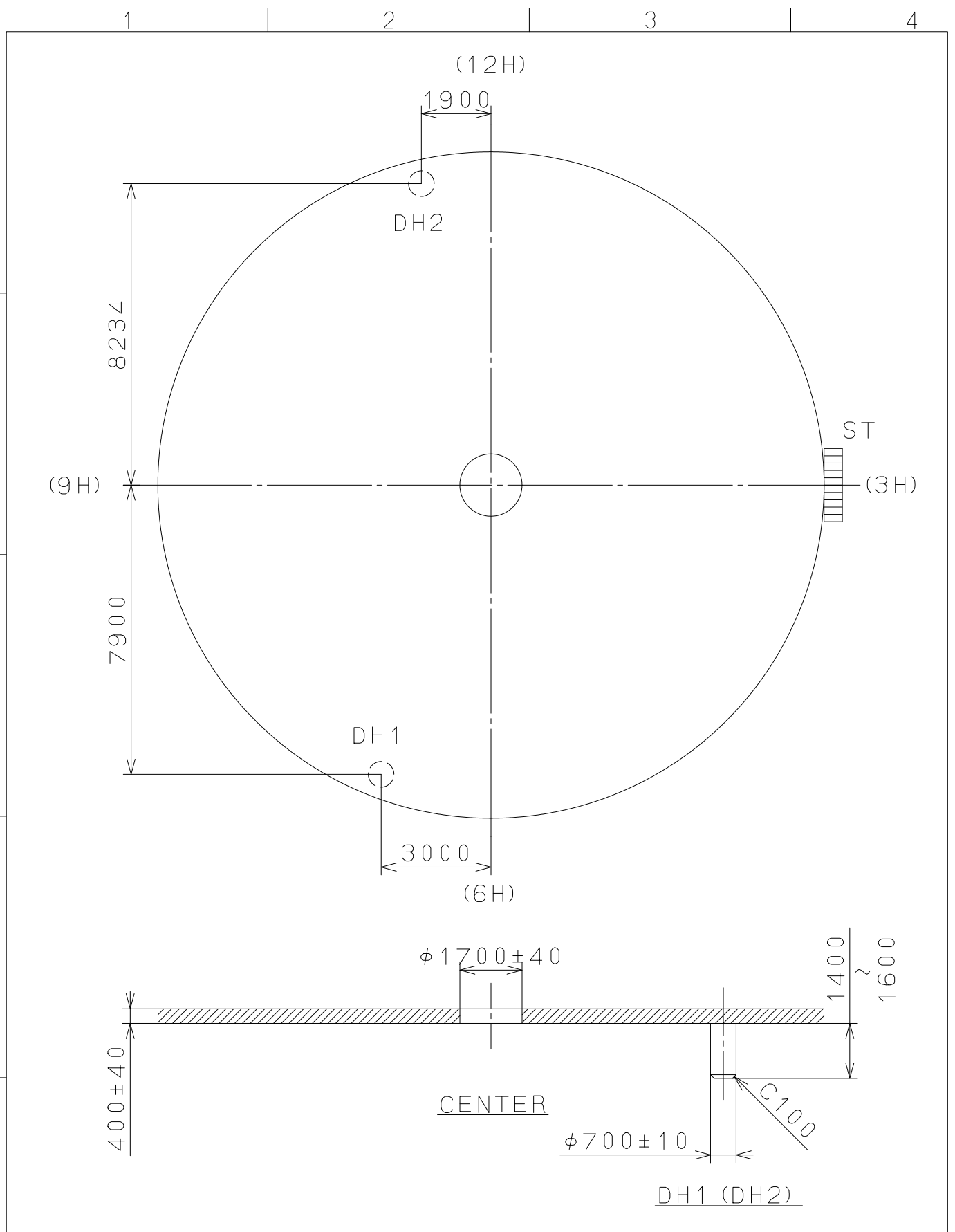

△			Quantity		Cal.NO.:
△			Unit	1 / 1000 mm	2039-00A
△			Scale	7 : 1	Parts No.:
△			Date		
△			Drawn		
Mark	Date	Description	Appro.	Checked	Name:
		Alterations		Approved	D. Yamada
Material					Indications for Dial
Heat Treatment					Drawing No.: 203900D0
Hardness					MIYOTA
Plating					

This drawing is provisional and subject to our reconfirmation and/or revision without notice.

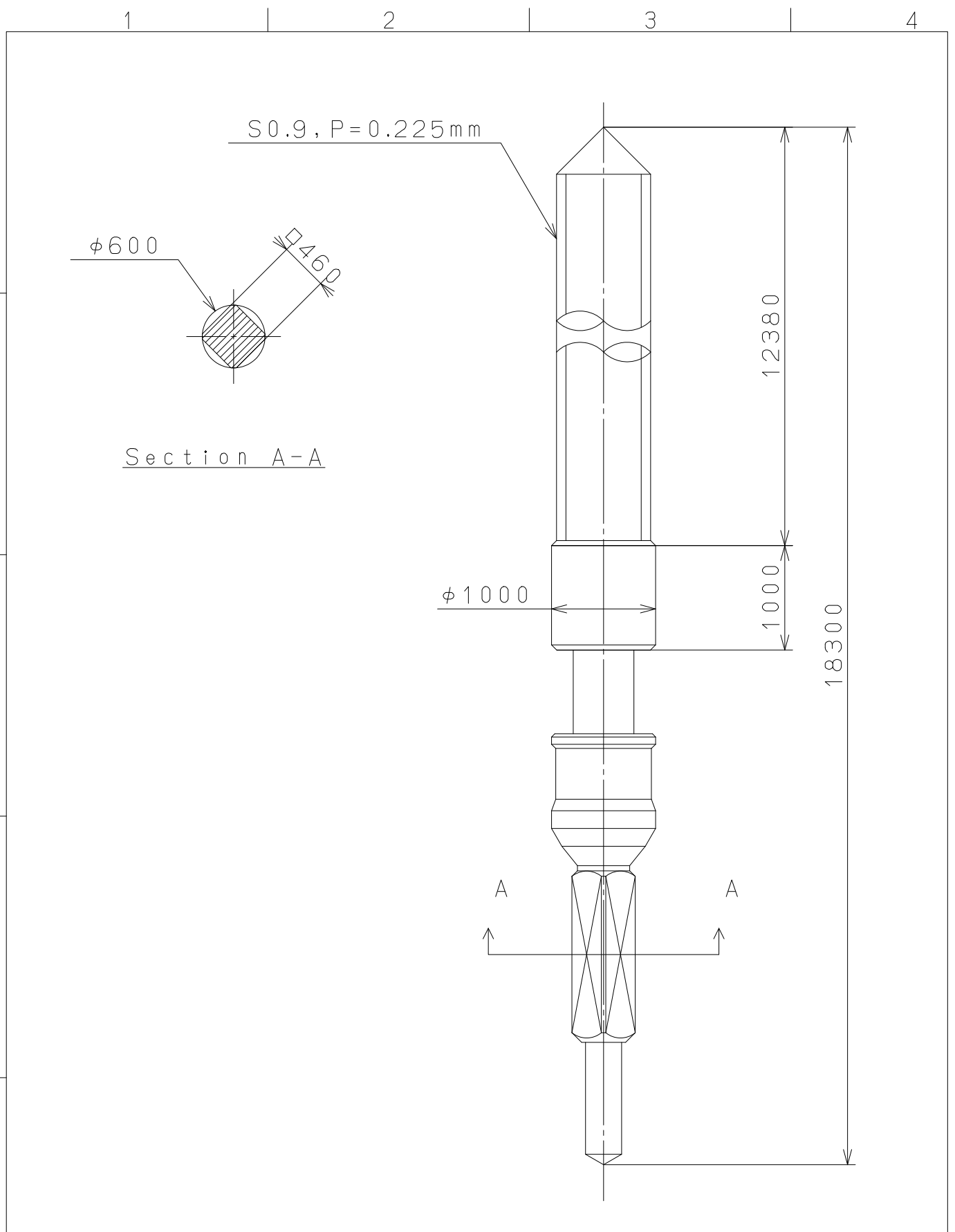

⑤			Quantity		Cal.NO.:
④			Unit	1 / 1000 mm	
③			Scale	20 : 1	Parts No.:
②			Date		065-299
①			Drawn		
Mark	Date	Description	Appro.	Checked	D. Yamada
Alterations			Approved	Name:	
			SETTING STEM		
Material					Drawing No.: 299000S0
Heat Treatment					MIYOTA CITIZEN WATCH CO., LTD. TOKYO, JAPAN
Hardness					
Plating					