

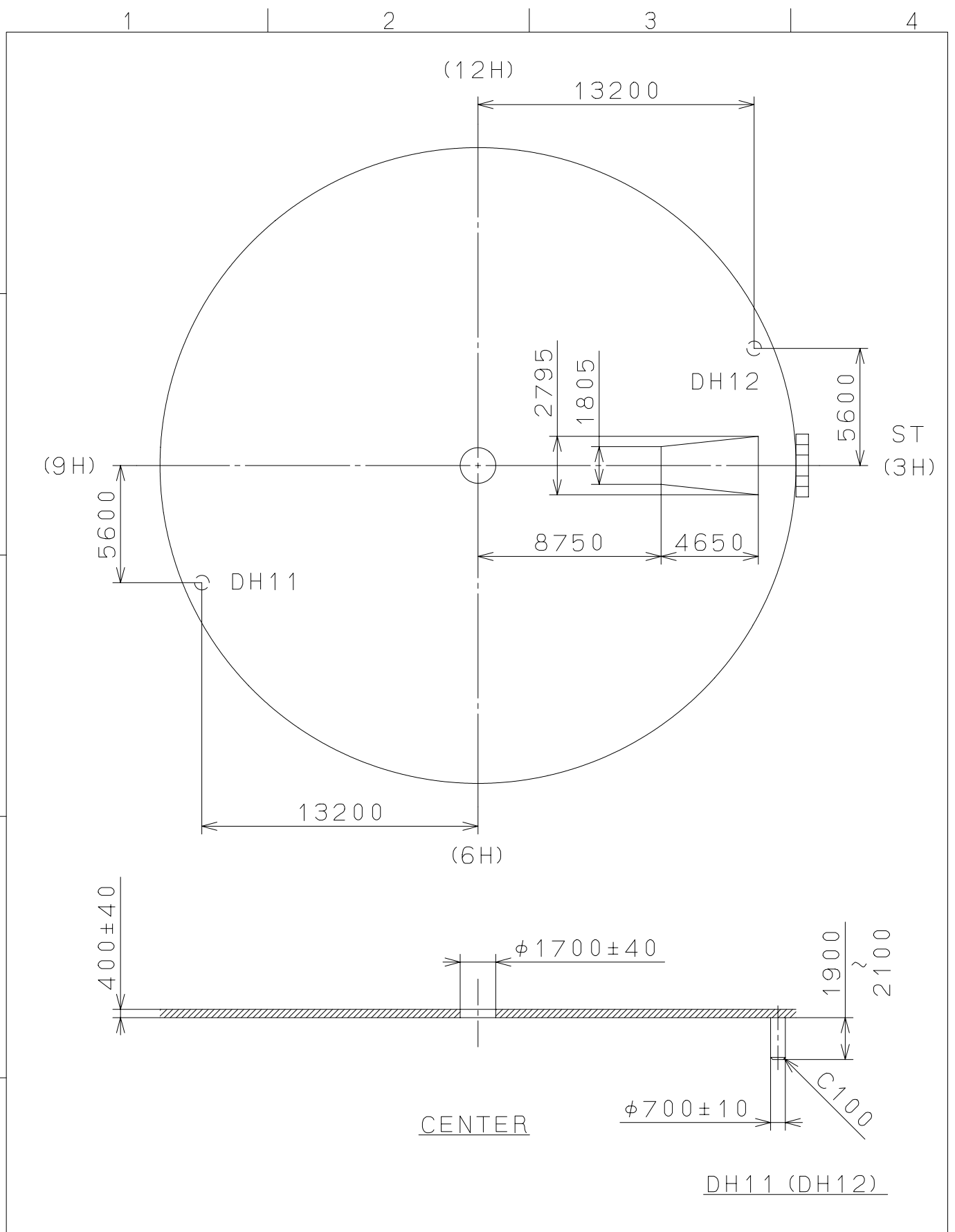

2007/03/16 (09:52:49)

This drawing is provisional and subject to our reconfirmation and/or revision without notice.



△			Quantity		Cal.NO.:
△			Unit	1 / 1000 <sub>mm</sub>	2453-00A
△			Scale	4 / 1	Parts No.:
△			Date		
△			Drawn		
Mark	Date	Description	Appr.	Checked	Name:
		Alterations		Approved	M. Fukuda
Material					Indications for Dial
Heat Treatment					Drawing No.: 2453D000
Hardness				General Tolerances	<b>MIYOTA</b>
Plating				Dimensions	
				Angles	CITIZEN WATCH CO., LTD. TOKYO, JAPAN

2007/03/16 (09:59:29)

This drawing is provisional and subject to our reconfirmation and/or revision without notice.

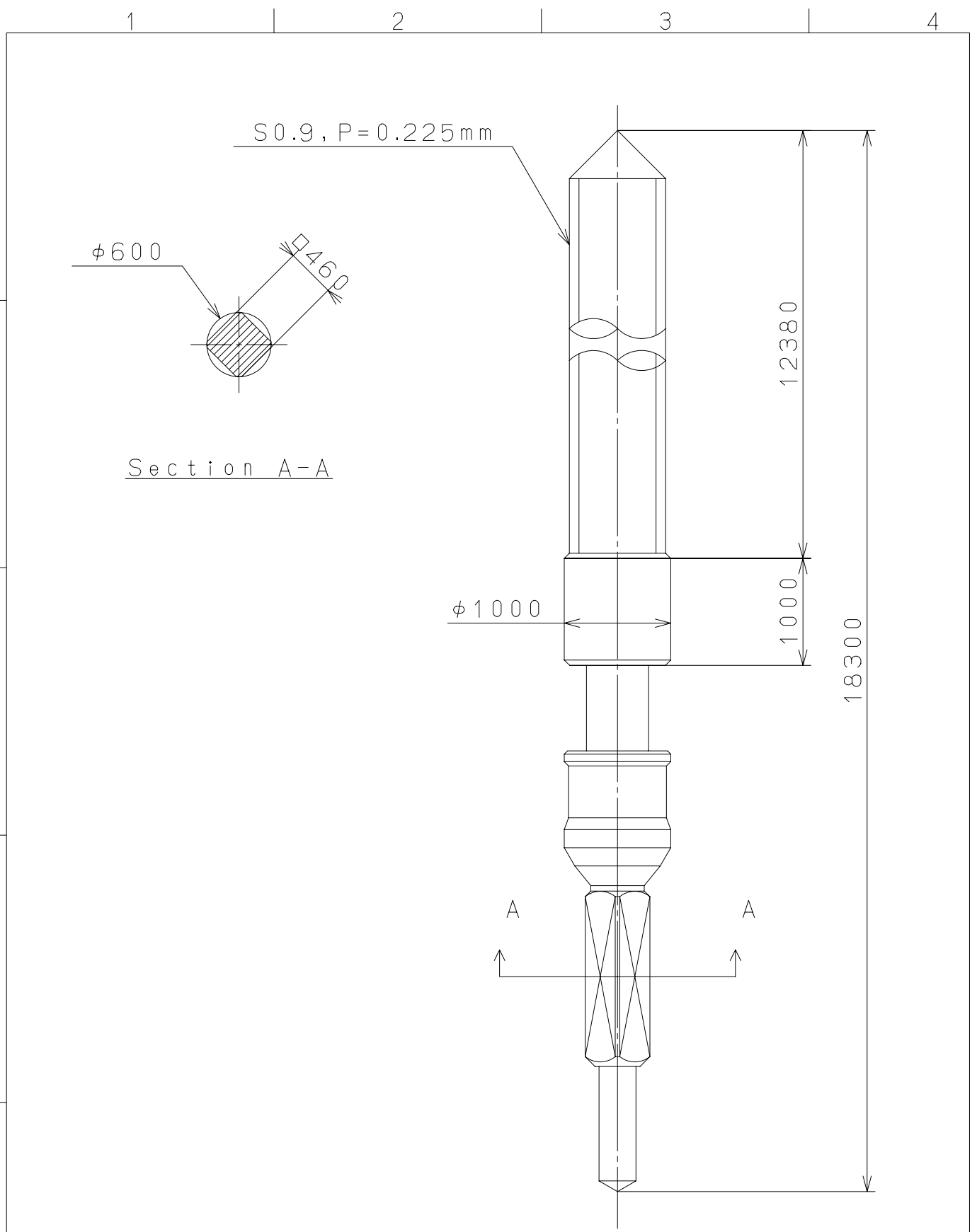

△			Quantity		Cal.NO.:
△			Unit	1 / 1000 mm	
△			Scale	20 / 1	Parts No.:
△			Date		065-299
△			Drawn		Name:
Mark	Date	Description	Appro.	Checked	T. Hiruta
Alterations			Approved	SETTING STEM	
Material					Drawing No.: 2990S000
Heat Treatment					<b>MIYOTA</b> CITIZEN WATCH CO., LTD. TOKYO, JAPAN
Hardness					
Plating					