

DH5~DH6=22287 (±20)

Coordinates

Mark	X	Y	R
GM	0	0	—
DH5	-8759	6900	—
DH6	8251	-7500	—
a 1	2351	11100	200
a 2	7235	9131	200
a 3	10800	3490	500
a 4	10800	-3490	500
a 5	3490	-10800	500
a 6	-2700	-11100	200
a 7	-5389	-10216	300
a 8	-10800	-3490	500
a 9	-10800	3490	500
a 10	-3490	10800	500
b 1	9581	6360	150
b 2	7928	8331	150
b 3	-5773	9946	150
b 4	-7839	8415	150
b 5	-9572	-6374	150
b 6	-7916	-8342	150
b 7	9196	-6906	150
b 8	10501	-4690	150

	H
With Battery strap	3600
Without Battery strap	3450

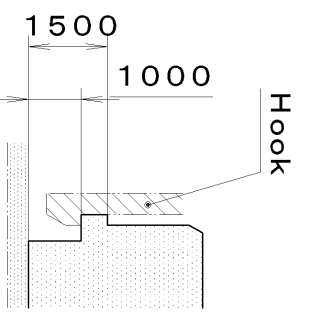
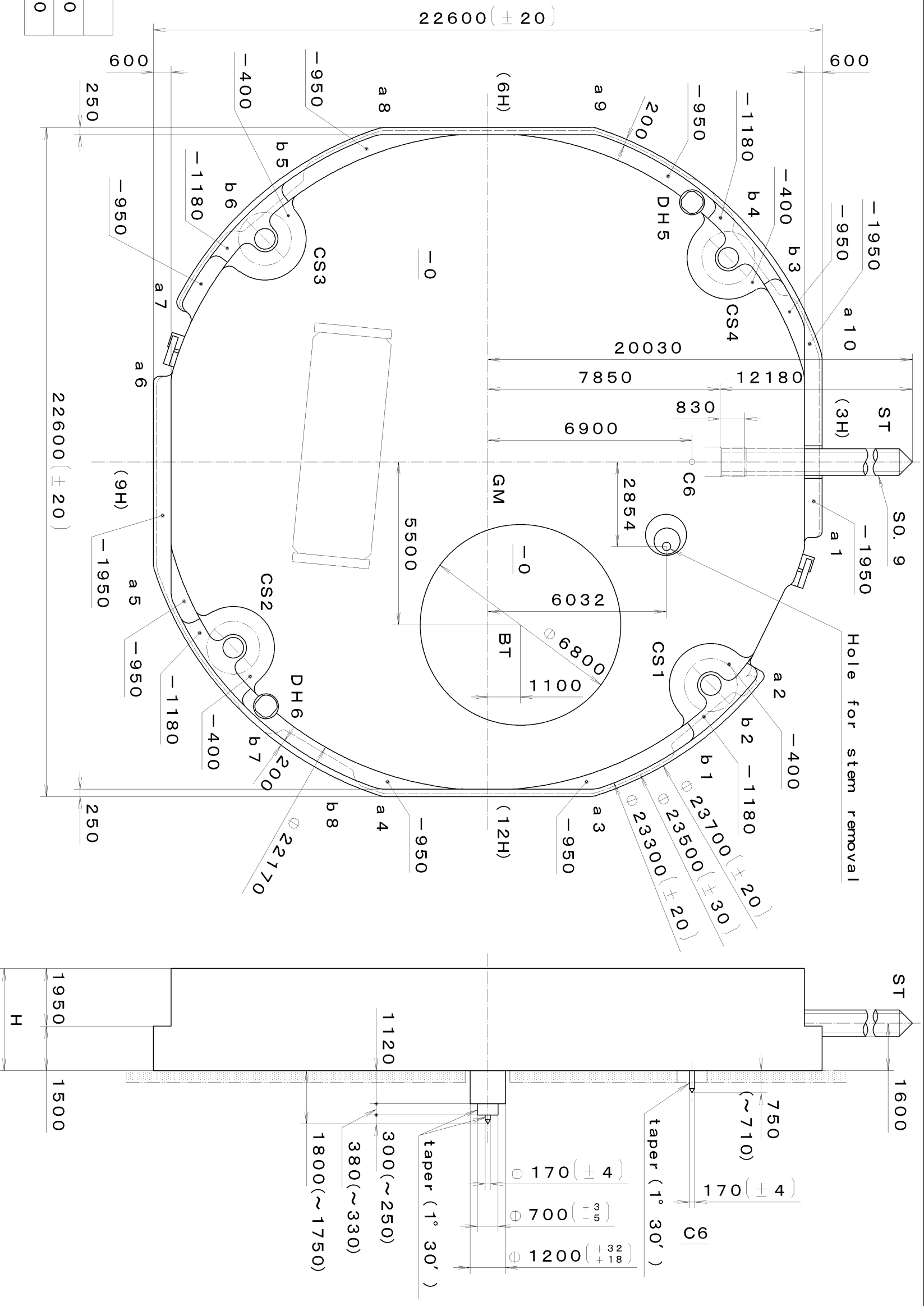

Section b1~b8

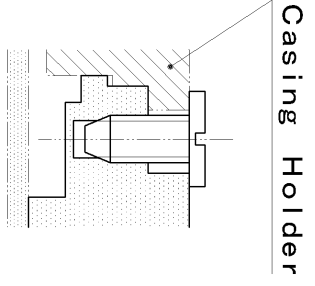

Section CS1~4

Quantity	Unit	1/1000 mm	Cal. No. : 6P26
△	△	△	Parts :
△	△	△	Date :
△	△	△	Drawn :
△	△	△	Checked : T. Hiruta
△	△	△	Approved :
Material			Name : Frame for Case
Heat Treatment			Drawing No. : 6P26C000
Hardness			
Plating			
General Tolerances			
Dimensions			
Angles			

MIYOTA

This drawing is provisional and subject to our reconfirmation and/or revision without notice.

*** T I P W 6P26-00A (01) *** (2100 1121) 03-01-27

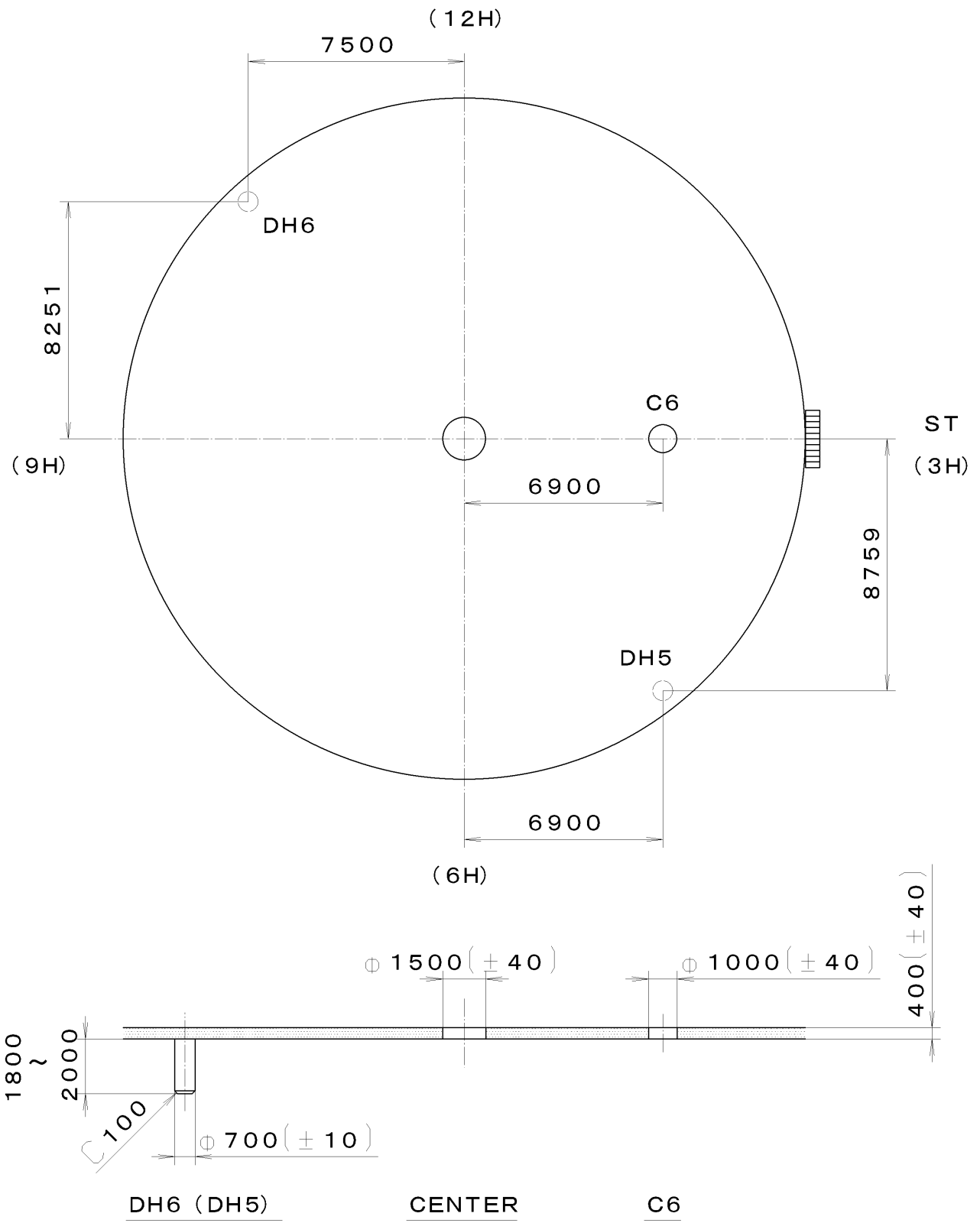

△1			Quantity		Cal. No. : 6P26-00A
△2			Unit	1/1000 mm	Parts:
△3			Scale	5:1	
△4			Date		Name: Indications for Dial
△5			Drawn		
△6			Checked	T. Hiruta	Drawing No. : 6P26D000
△7			Approved		
Material					MIYOTA
Heat Treatment			General Tolerances		
Hardness			Dimensions		
Plating			Angles		

2010/05/12 (17:15:34)

This drawing is provisional and subject to our reconfirmation and/or revision without notice.

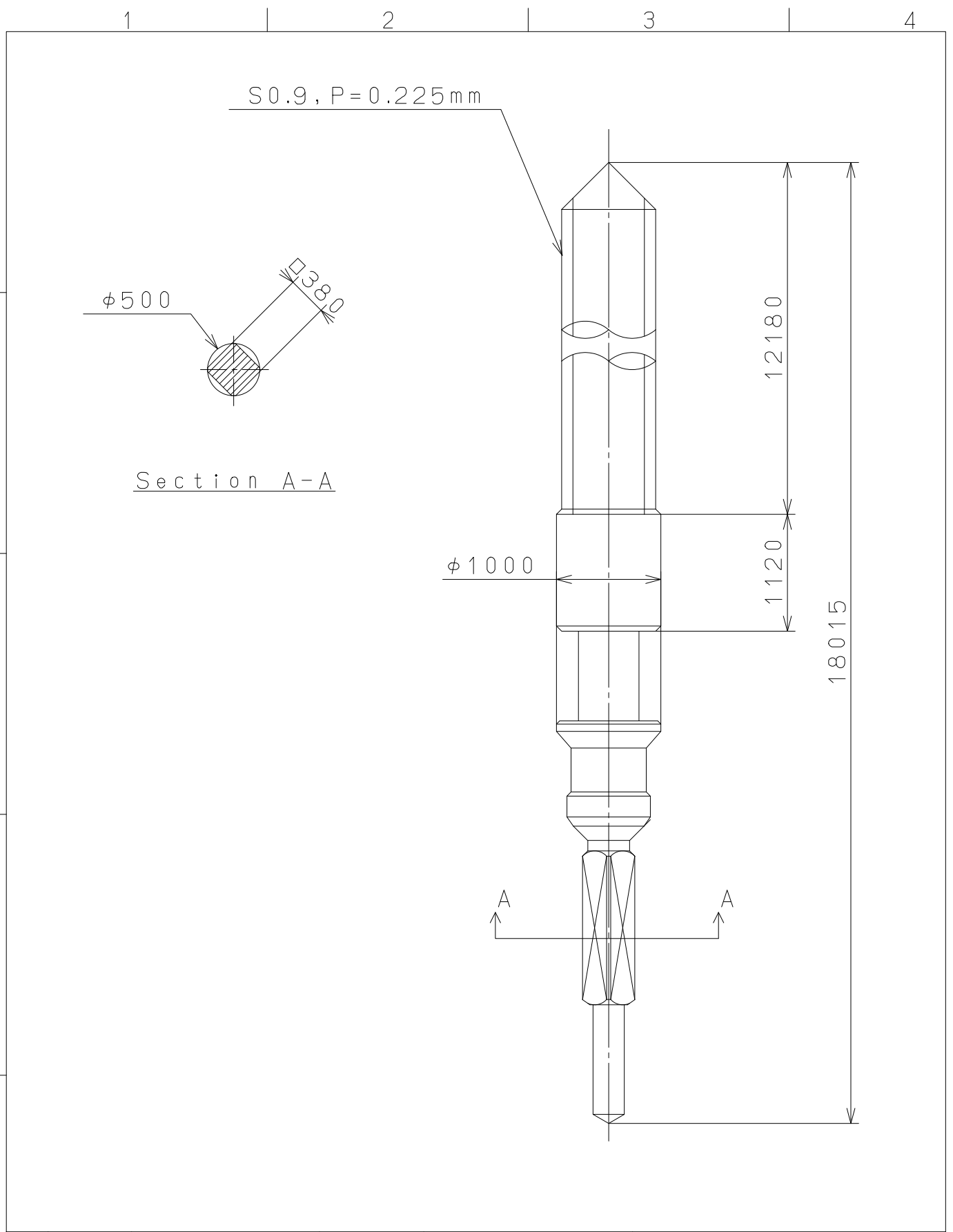

⑤			Quantity		Cal.NO.:
④			Unit	1/1000mm	
③			Scale	20:1	Parts No.:
②			Date		065-379
①			Drawn		
Mark	Date	Description	Appro.	Checked	T.Hiruta
Alterations			Approved	Name:	
			SETTING STEM		
Material					Drawing No.:3790S000
Heat Treatment					MIYOTA CITIZEN WATCH CO.,LTD. TOKYO,JAPAN
Hardness					
Plating					