

This drawing is provisional and subject to our reconfirmation and/or revision without notice.

DH5~DH6=22287±20

Coordinates			
Mark	X	Y	R
GM	0	0	—
DH5	-8759	6900	—
DH6	8251	-7500	—
a1	2351	11100	200
a2	7235	9131	200
a3	10800	3490	500
a4	10800	-3490	500
a5	3490	-10800	500
a6	-2700	-11100	200
a7	-5389	-10216	300
a8	-10800	-3490	500
a9	-10800	3490	500
a10	-3490	10800	500
b1	9581	6360	150
b2	7928	8331	150
b3	-5773	9946	150
b4	-7839	8415	150
b5	-9572	-6374	150
b6	-7916	-8342	150
b7	9196	-6906	150
b8	10501	-4690	150

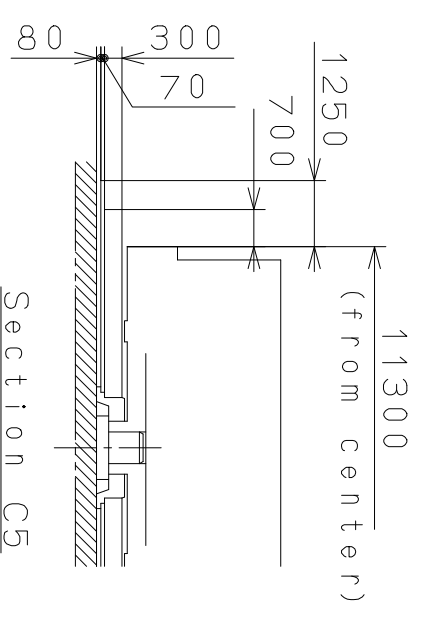
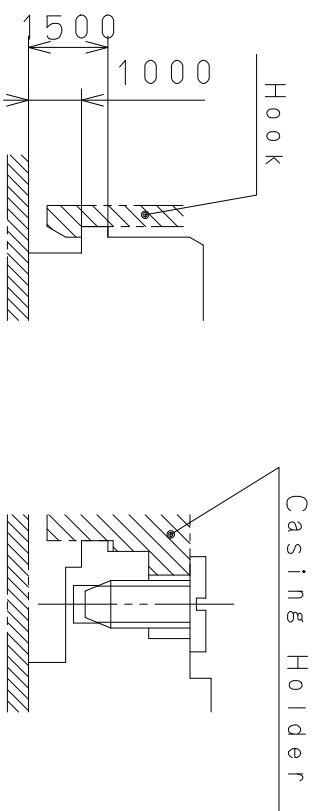
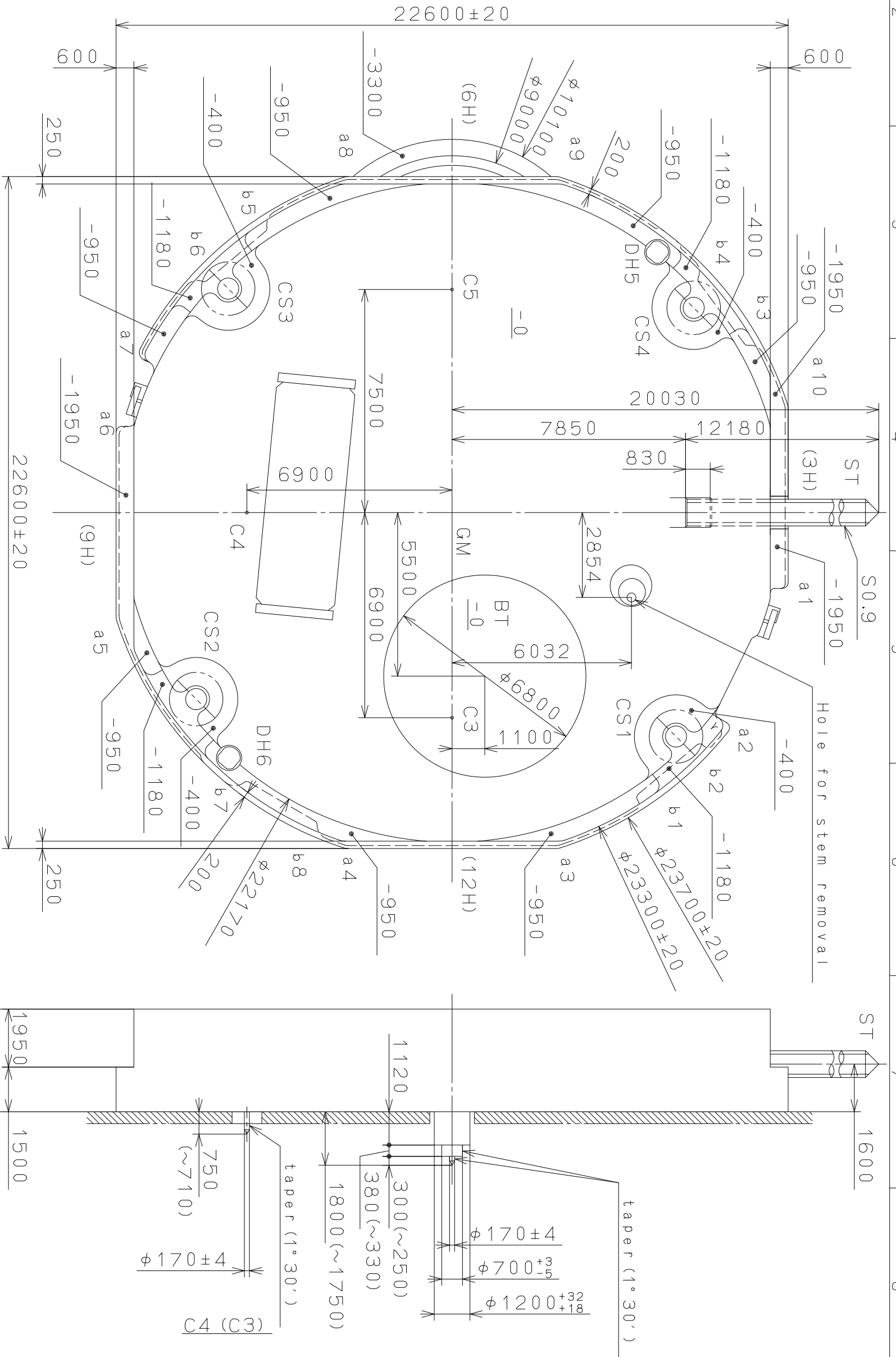

Material	Alterations	Date	Description	Appr.	Checked	Drawn	D. Yamada	Name:	Frame for Case
Heat Treatment									
Hardness									
Plating									
Quantity	Unit	Cal. NO.:		GP21		Parts No.:		Drawing No.: 6P2100C0	
Scale	7 : 1								
Material	General Tolerances								
Heat Treatment	Dimensions								
Hardness	Angles								
Plating									

**MIYOTA**  
CITIZEN WATCH CO., LTD. TOKYO, JAPAN

This drawing is provisional and subject to our reconfirmation and/or revision without notice.

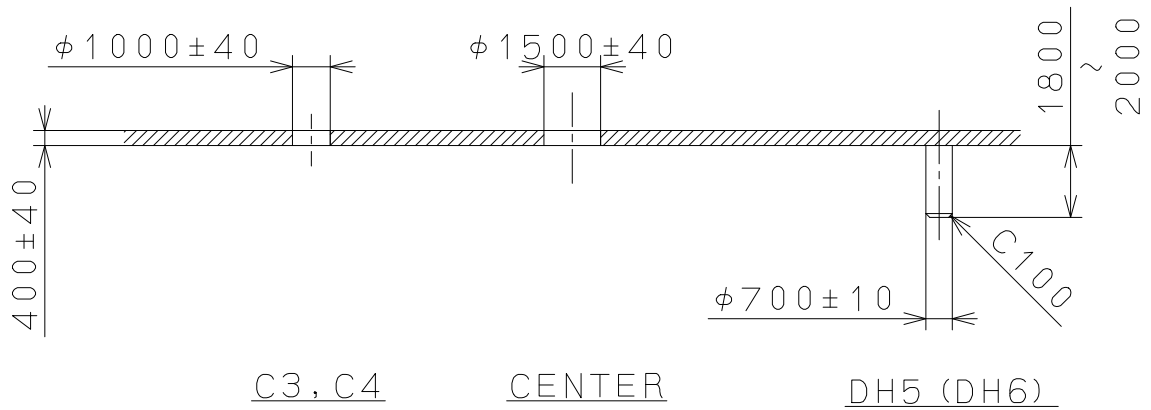
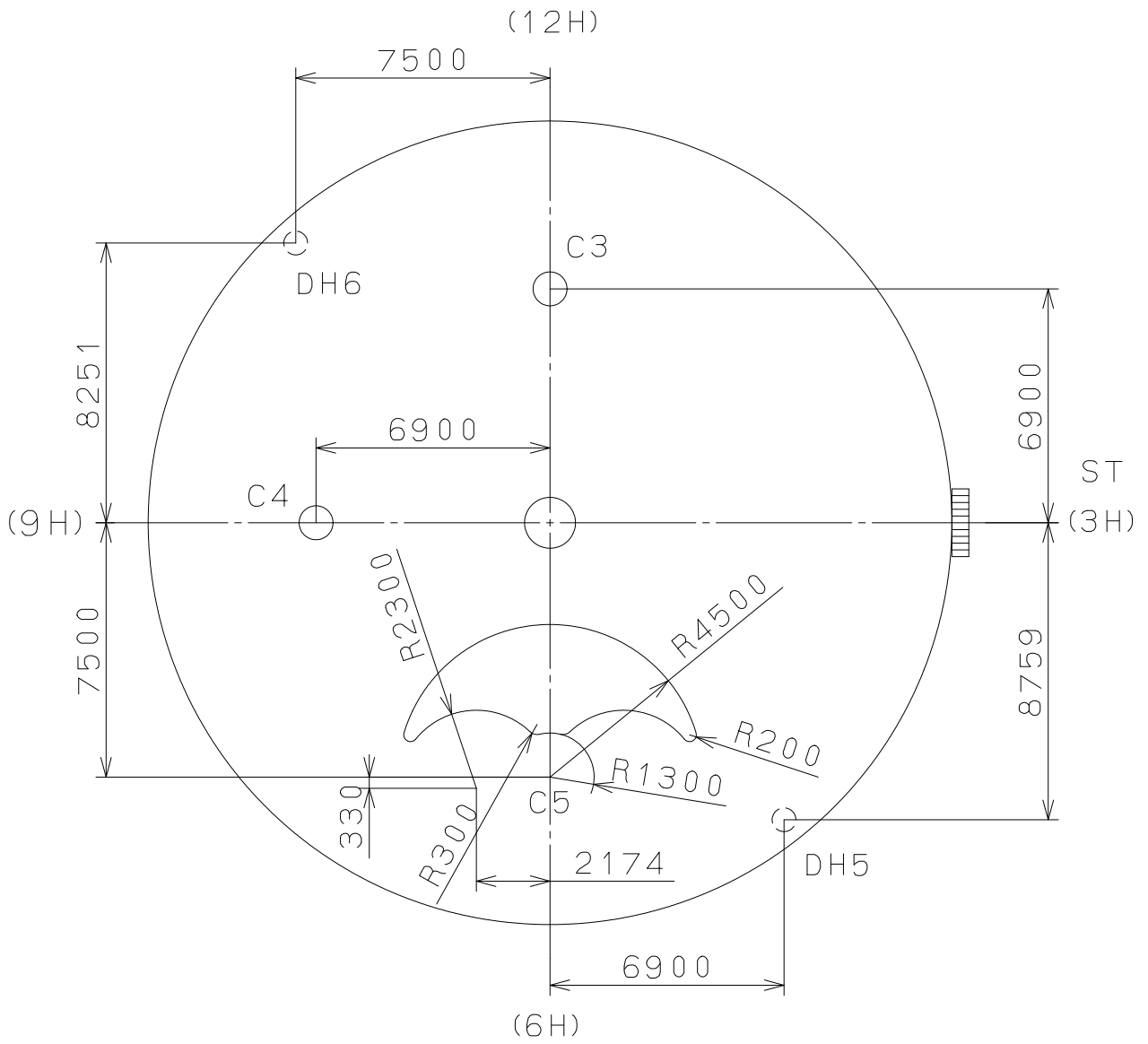

△			Quantity		Cal.NO.:
△			Unit	1/1000mm	6P21-00A
△			Scale	5:1	Parts No.:
△			Date		
△			Drawn		
Mark	Date	Description	Appr.	Checked	Name:
		Alterations	Approved	D. Yamada	Indications for Dial
Material					Drawing No.: 6P2100D0
Heat Treatment			General Tolerances		<b>MIYOTA</b>
Hardness			Dimensions		
Plating			Angles		
					CITIZEN WATCH CO., LTD. TOKYO, JAPAN

This drawing is provisional and subject to our reconfirmation and/or revision without notice.

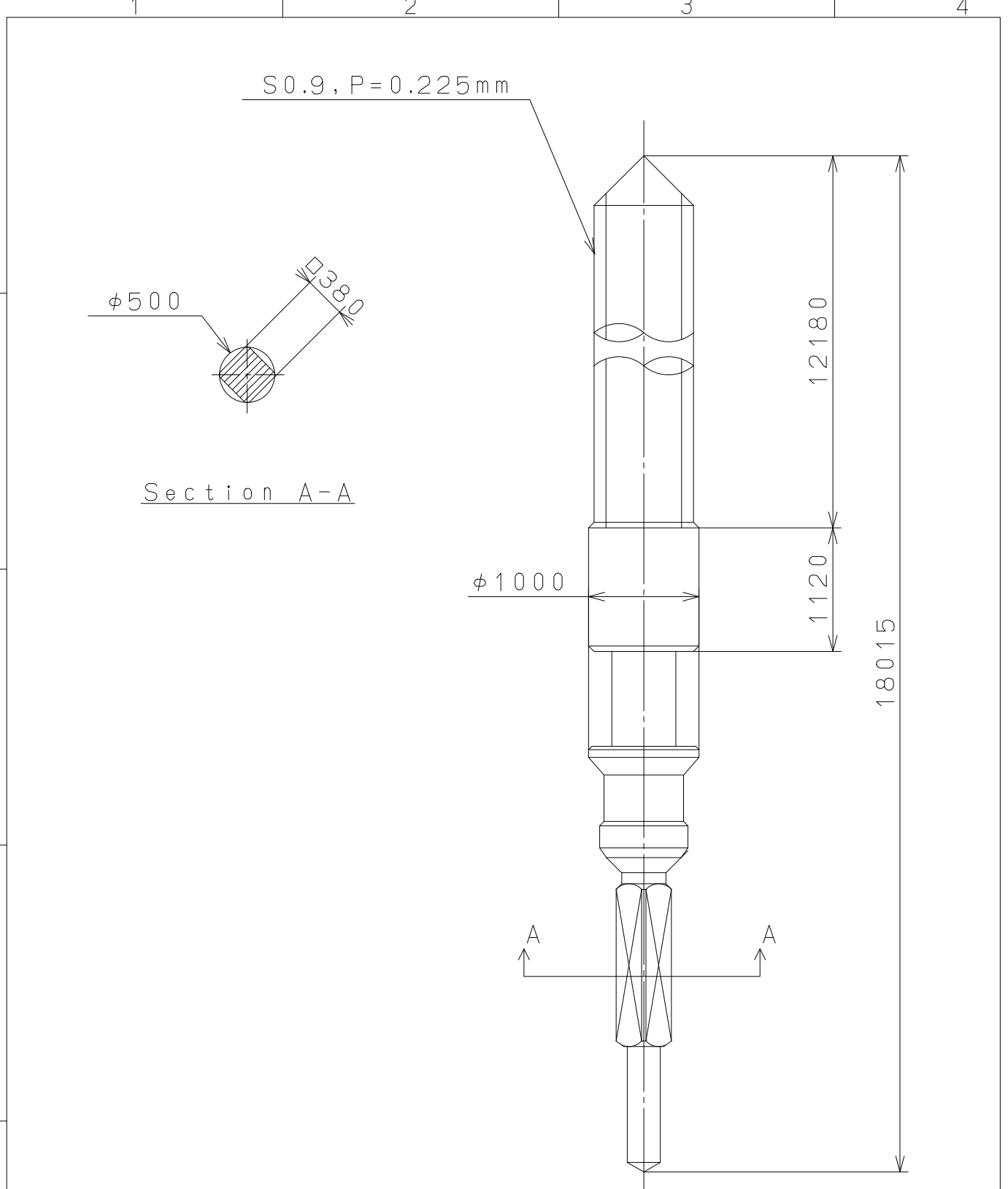

△			Quantity		Cal.NO.:
△			Unit	1 / 1000 mm	
△			Scale	20 : 1	Parts No.:
△			Date		065-379
△			Drawn		
Mark	Date	Description	Appro.	Checked	D. Yamada
Alterations			Approved	Name: SETTING STEM	
Material					Drawing No.: 379000S0
Heat Treatment					<b>MIYOTA</b>
Hardness					
Plating					
					CITIZEN WATCH CO., LTD. TOKYO, JAPAN