

DH1~DH2=25816 (±20)

Coordinates

記号	X	Y	R
GM	0	0	—
DH1	3000	13000	—
DH2	2100	-12800	—
a1	3441	14908	430
a2	1360	14720	320
a3	-15151	2129	430
a4	-15291	535	430
a5	10434	-11190	430
a6	9208	-12219	430

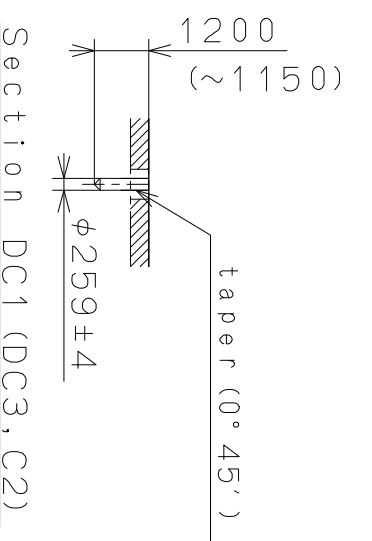
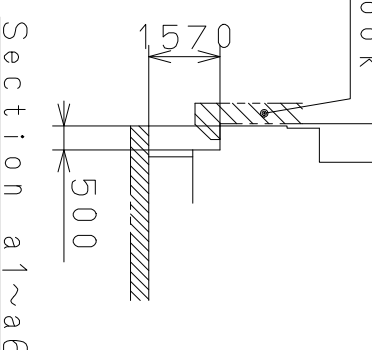
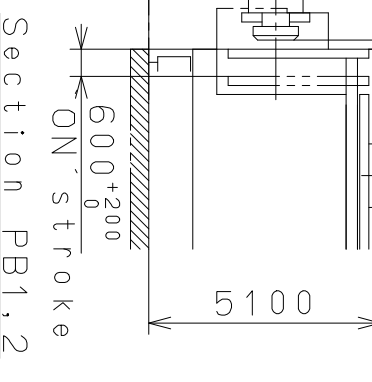
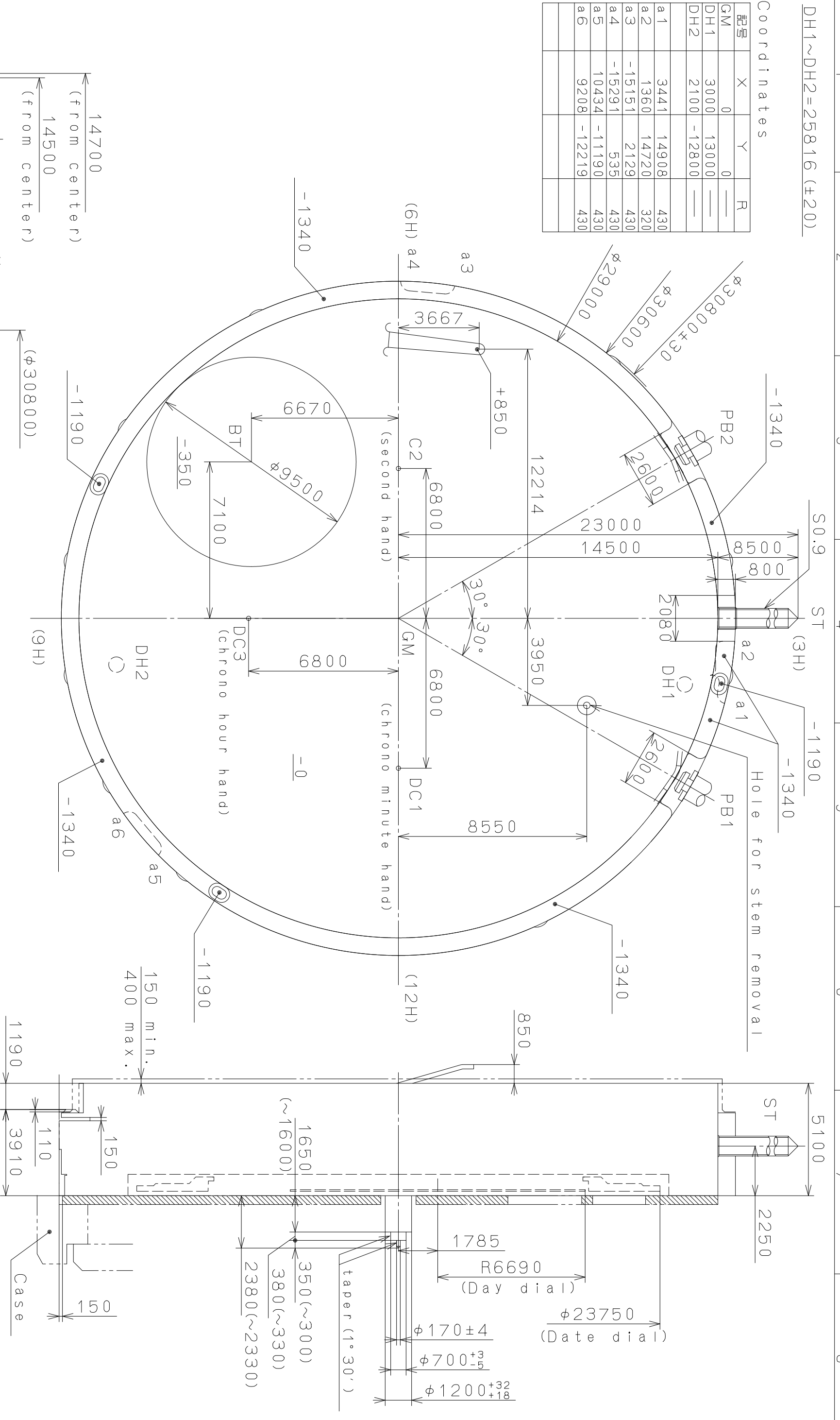

Mark	Date	Description	Appro.	Checked	Drawn	Name:
Alterations						N. Suzuki
Material						Frame for Case
Heat Treatment						Drawing No.: OS06C001
Hardness						
Plating						

Quantity	Unit	Cal. NO.:
1	1/1000 mm	OS06
Scale	6 : 1	Parts No.:
General Tolerances		Dimensions
Angles		Case

This drawing is provisional and subject to our reconfirmation and/or revision without notice.

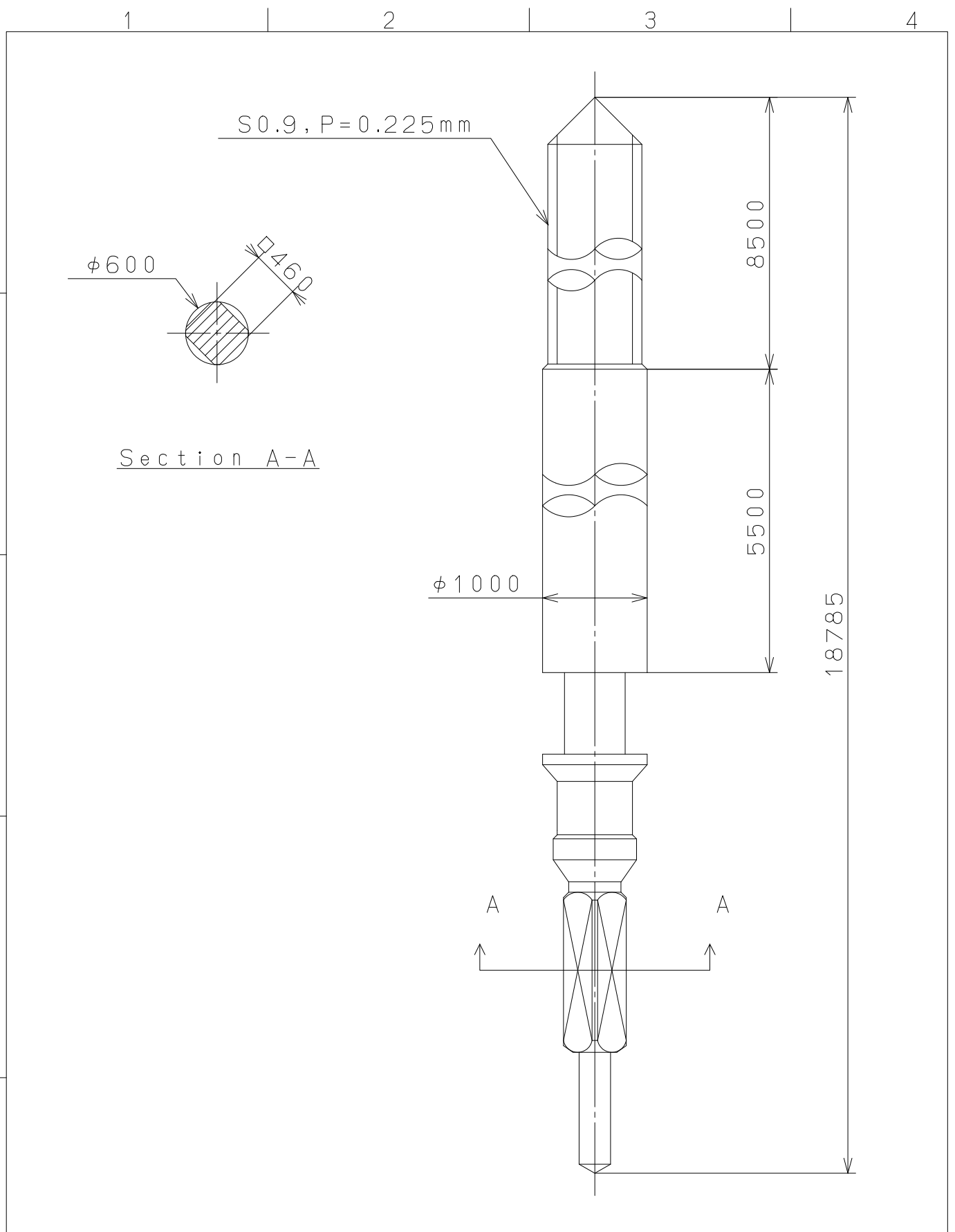

△5			Quantity		Cal.NO.:	
△4			Unit	1 / 1000 mm		
△3			Scale	20 : 1	Parts No.:	
△2			Date		065-453	
△1			Drawn			
Mark	Date	Description	Appro.	Checked	E. Murakami	Name:
Alterations			Approved	SETTING STEM		
Material					Drawing No.: 4530S000	
Heat Treatment					MIYOTA CITIZEN WATCH CO., LTD. TOKYO, JAPAN	
Hardness						
Plating						