

This drawing is provisional and subject to our reconfirmation and/or revision without notice.

xxx T1PW 6P25 (01) xxx (2100 1121) 00-07-25

DH5~DH6=22287 (±20)

Coordinates

Mark	X	Y	R
GM	0	0	—
DH5	-9759	6900	—
DH6	8251	-7500	—
a1	2351	11100	200
a2	7235	9131	200
a3	10800	3490	500
a4	10800	-3490	500
a5	3490	-10800	500
a6	-2700	-11100	200
a7	-5389	-10216	300
a8	-10800	-3490	500
a9	-10800	3490	500
a10	-3490	10800	500
b1	9591	6360	150
b2	7928	8331	150
b3	-5773	9946	150
b4	-7839	8415	150
b5	-9572	-6374	150
b6	-7916	-8342	150
b7	9196	-6906	150
b8	10501	-4690	150

With Battery strap	H
Without Battery strap	3450

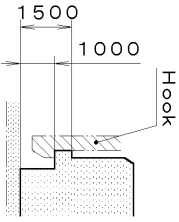
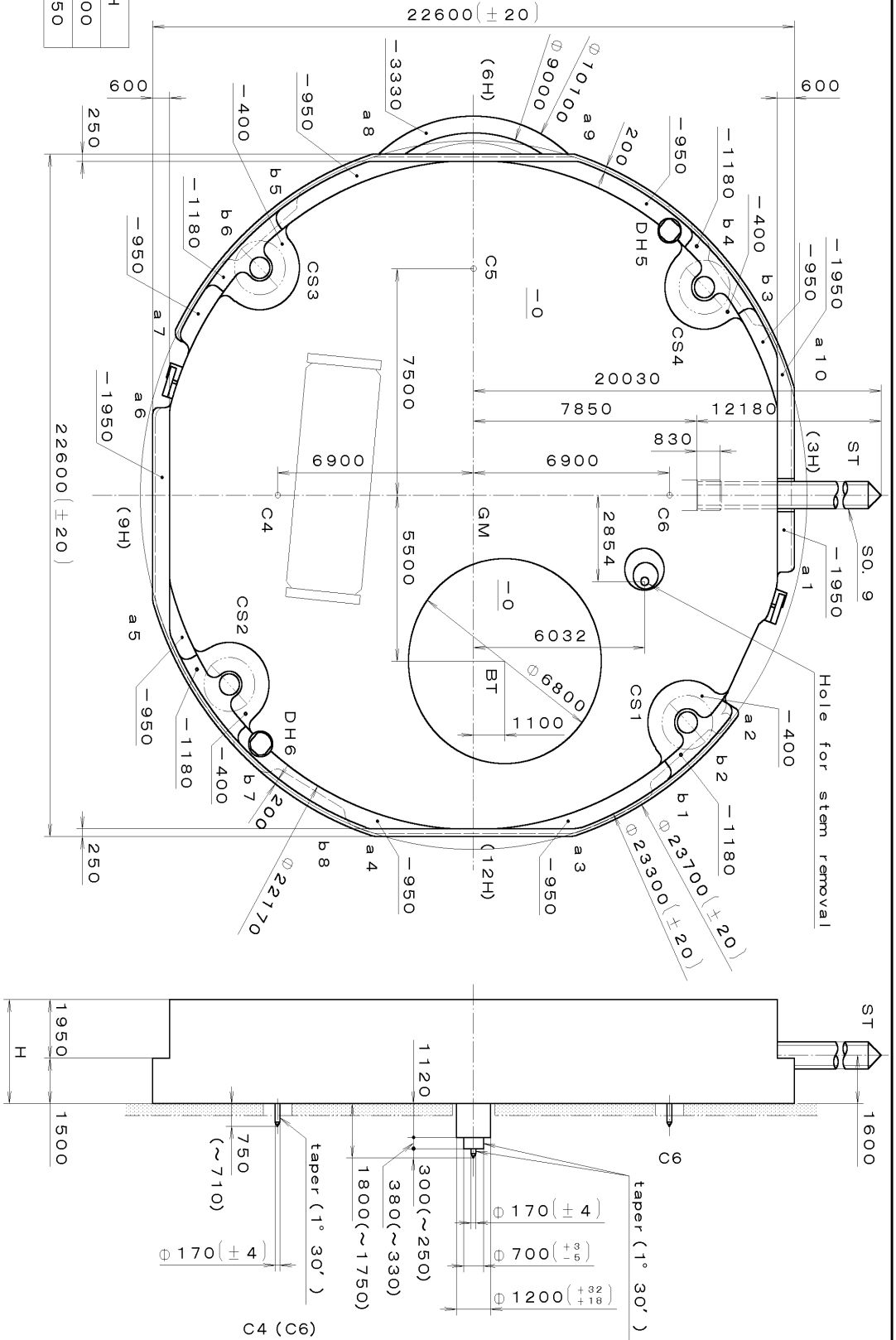

Section b1~b8

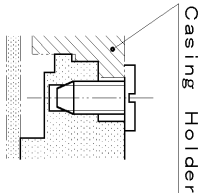

Section CS1~4

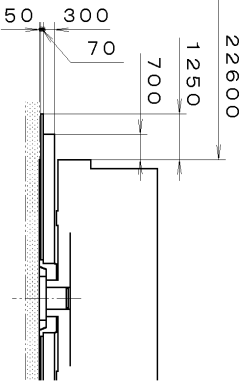

Section C5

Material	Quantity	Unit	Cal. No. :
Heat Treatment	1/1000	mm	6P25
Hardness	Scale	7:1	Parts:
Plating	Date		Drawn
	Checked	T. Hiruta	Checked
	Approved		Approved
Material		Name: Frame for Case	
Heat Treatment		Drawing No. : 6P25C0000	
Hardness			
Plating			
General Tolerances			
Dimensions			
Angles			

This drawing is provisional and subject to our reconfirmation and/or revision without notice.

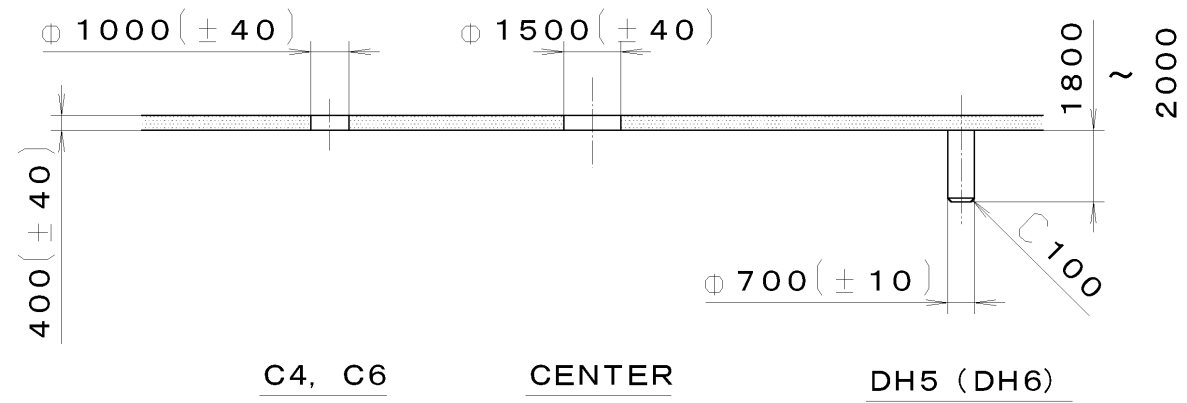
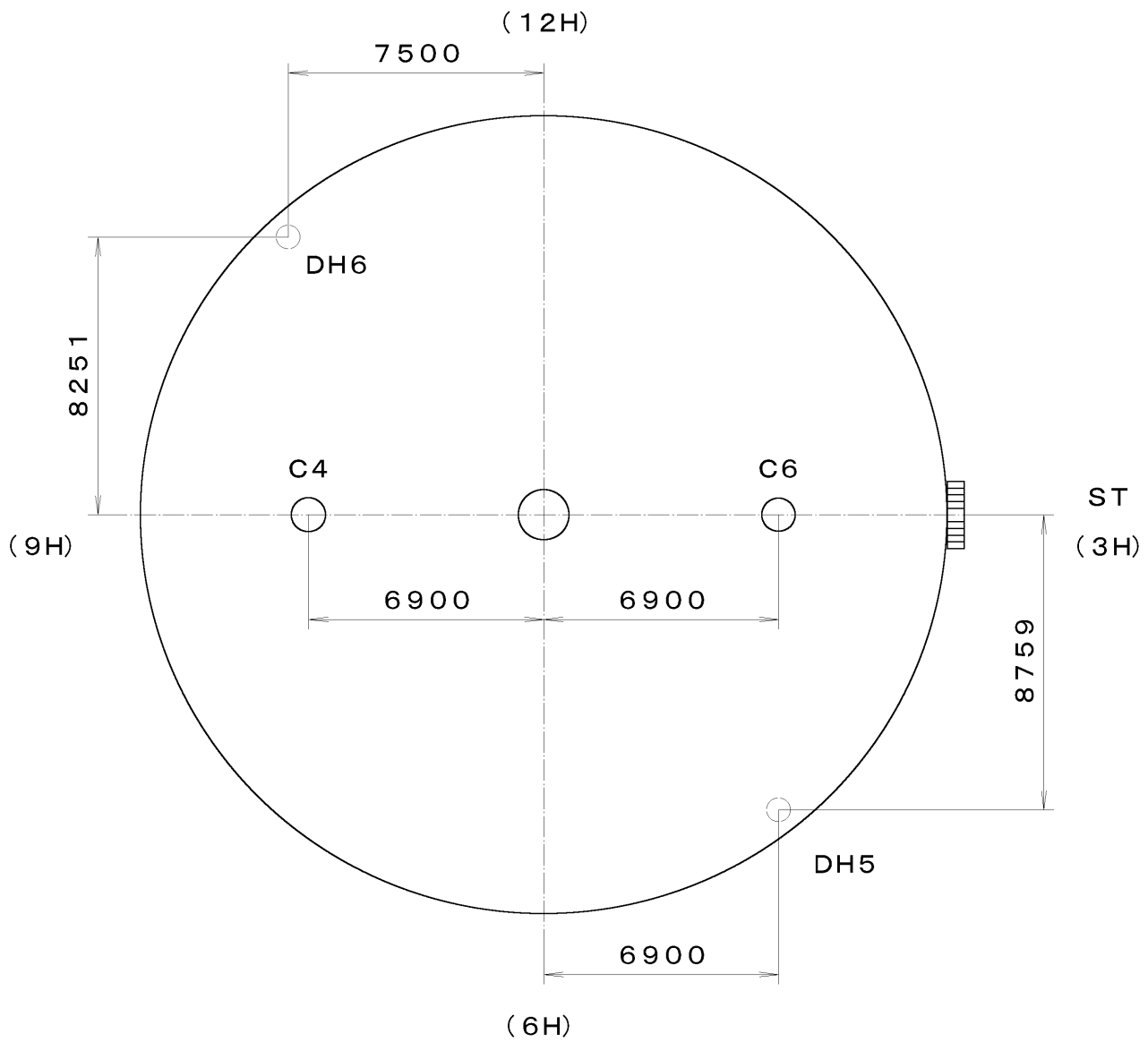

*** T I P W 6P25-00A (01) *** (2100 1121) 01-12-07

7		Quantity		Cal. No. :	6P25-00A
6		Unit	1/1000 mm	Parts:	
5		Scale	5:1	Name:	Indications for Dial
4		Date		Drawing No. :	
3		Drawn		Material	
2		Checked	T. Hiruta	Heat Treatment	
1		Approved		Hardness	
		General Tolerances			
		Dimensions			
		Angles			

This drawing is provisional and subject to our reconfirmation and/or revision without notice.

065-379 (01) *** (2100 1121) 00-06-23

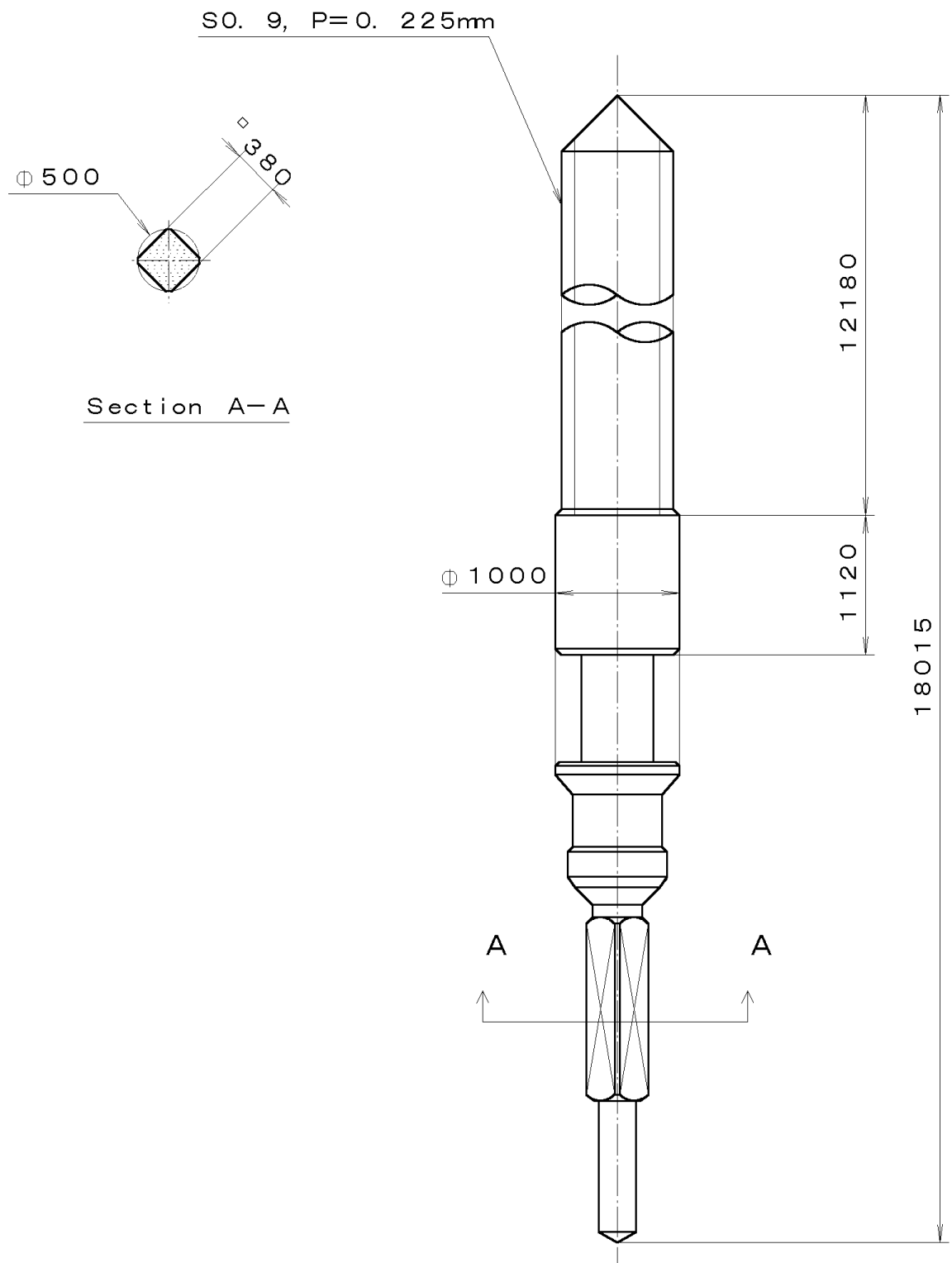

7		Quantity		Cal. No. :
6		Unit	1/1000 mm	Parts:
5		Scale	20:1	
4		Date		
3		Drawn		065-379
2		Checked	T. Hiruta	Name:
1		Approved		SETTING STEM
Material				Drawing No. : 3790S000
Heat Treatment		General Tolerances		
Hardness		Dimensions		
Plating		Angles		