

This drawing is provisional and subject to our reconfirmation and/or revision without notice.

xxx TIPW 6P05 (01) xxx (2100 1121 ) 00-07-19

DH5~DH6=22287 (±20)

Coordinates

Mark	X	Y	R
GM	0	0	—
DH5	-8759	6900	—
DH6	8251	-7500	—
a1	2351	11100	200
a2	7235	9131	200
a3	10800	3490	500
a4	10800	-3490	500
a5	3490	-10500	500
a6	-2700	-11100	200
a7	-5389	-10216	300
a8	-10800	-3490	500
a9	-10800	3490	500
a10	-3490	10800	500
b1	9581	6360	150
b2	7928	8331	150
b3	-5773	9946	150
b4	-7839	8415	150
b5	-9572	-6374	150
b6	-7916	-8342	150
b7	9196	-6906	150
b8	10501	-4690	150

	H
With Battery strap	3600
Without Battery strap	3450

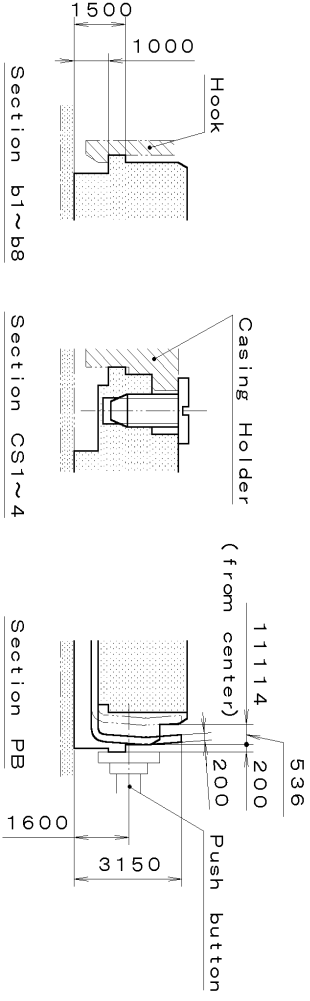
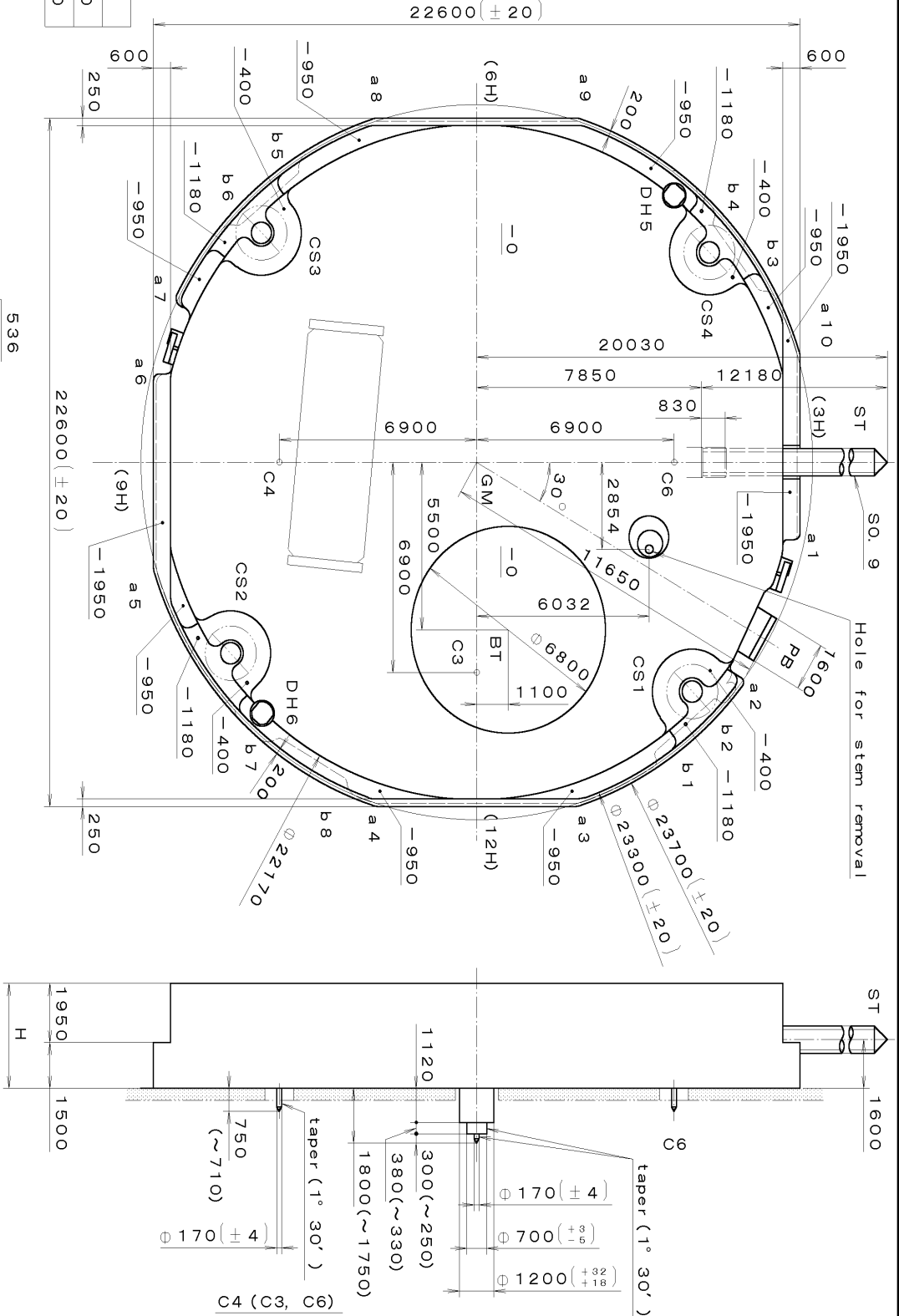

Material	Quantity	Unit	Cal. No. :
Heat Treatment		1/1000 mm	6P05
Hardness		Scale	Parts:
Plating		7:1	
		Date	
		Drawn	
		Checked	T. Hiruta
		Approved	
Material			Name :
General Tolerances			Frame for Case
Dimensions			Drawing No. : 6P05C000
Angles			

**MIYOTA**

This drawing is provisional and subject to our reconfirmation and/or revision without notice.

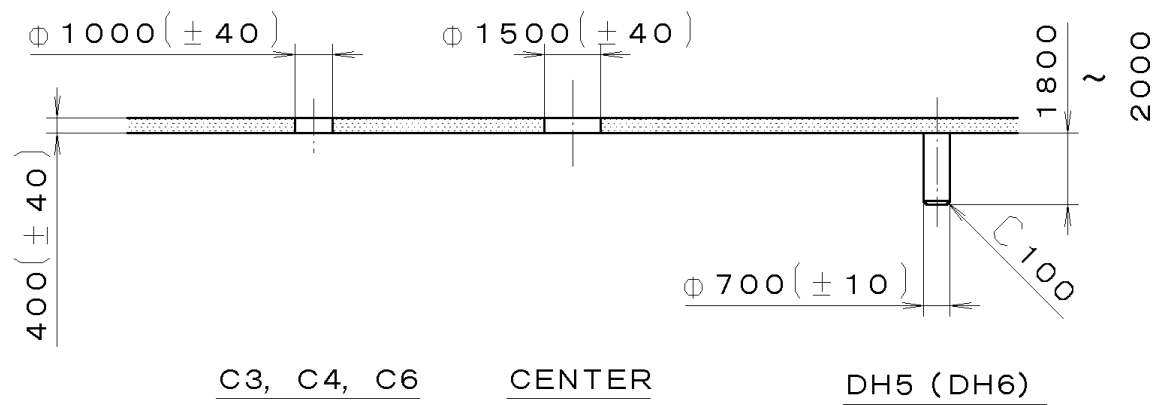
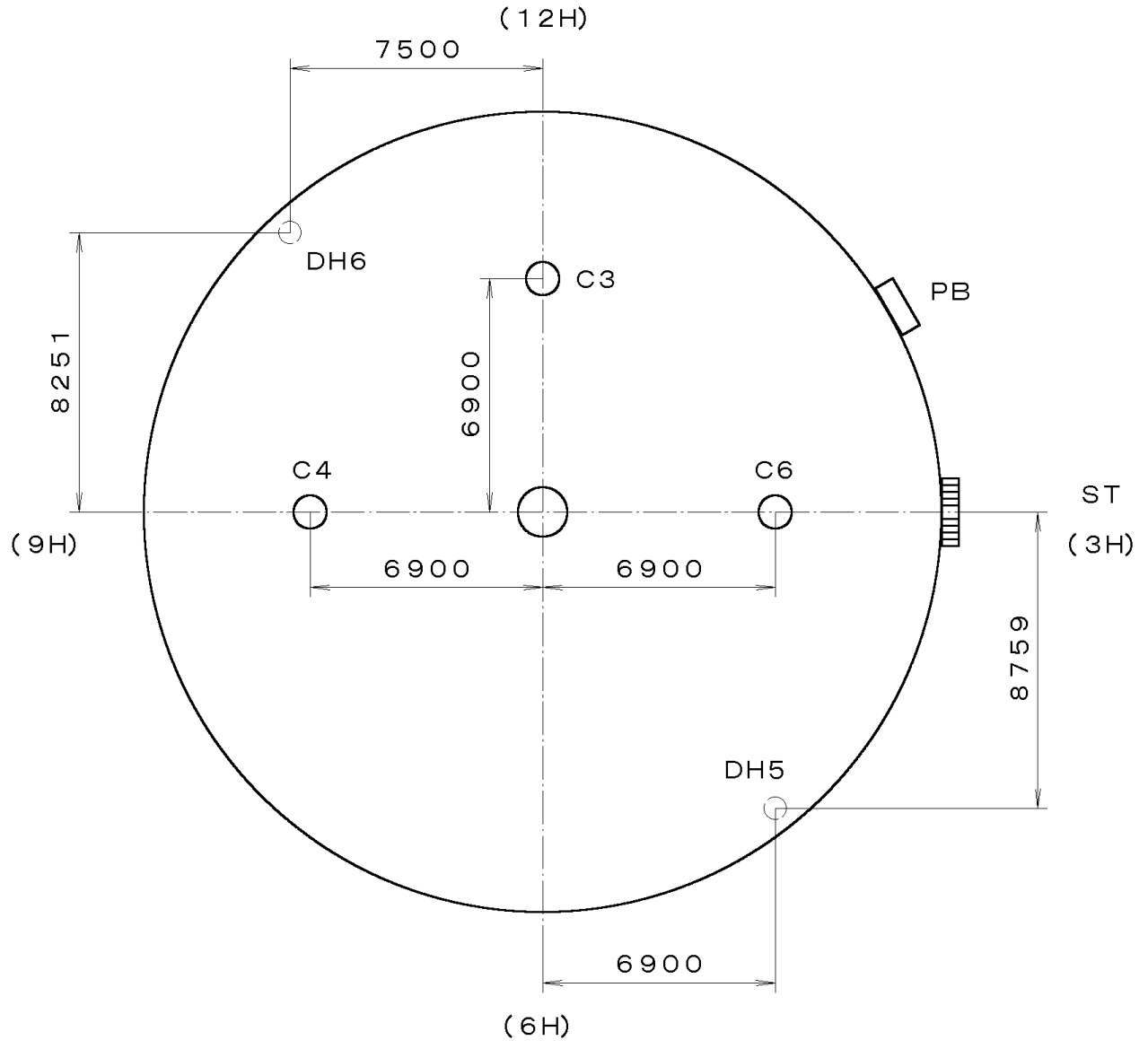

C3, C4, C6      CENTER      DH5 (DH6)

*** T I P W 6P05-00A (01) *** (2100 1121)	7	Quantity		Cal. No. : <b>6P05-00A</b>
	6	Unit	1/1000 mm	
	5	Scale	5:1	Parts:
	4	Date		
	3	Drawn		
	2	Checked	T. Hiruta	Name:
1	Approved		Indications for Dial	
Material				Drawing No. : 6P05D000
Heat Treatment		General Tolerances		<b>MIYOTA</b>
Hardness		Dimensions		
Plating		Angles		

00-07-24

2010/05/12 (17:15:34)

This drawing is provisional and subject to our reconfirmation and/or revision without notice.

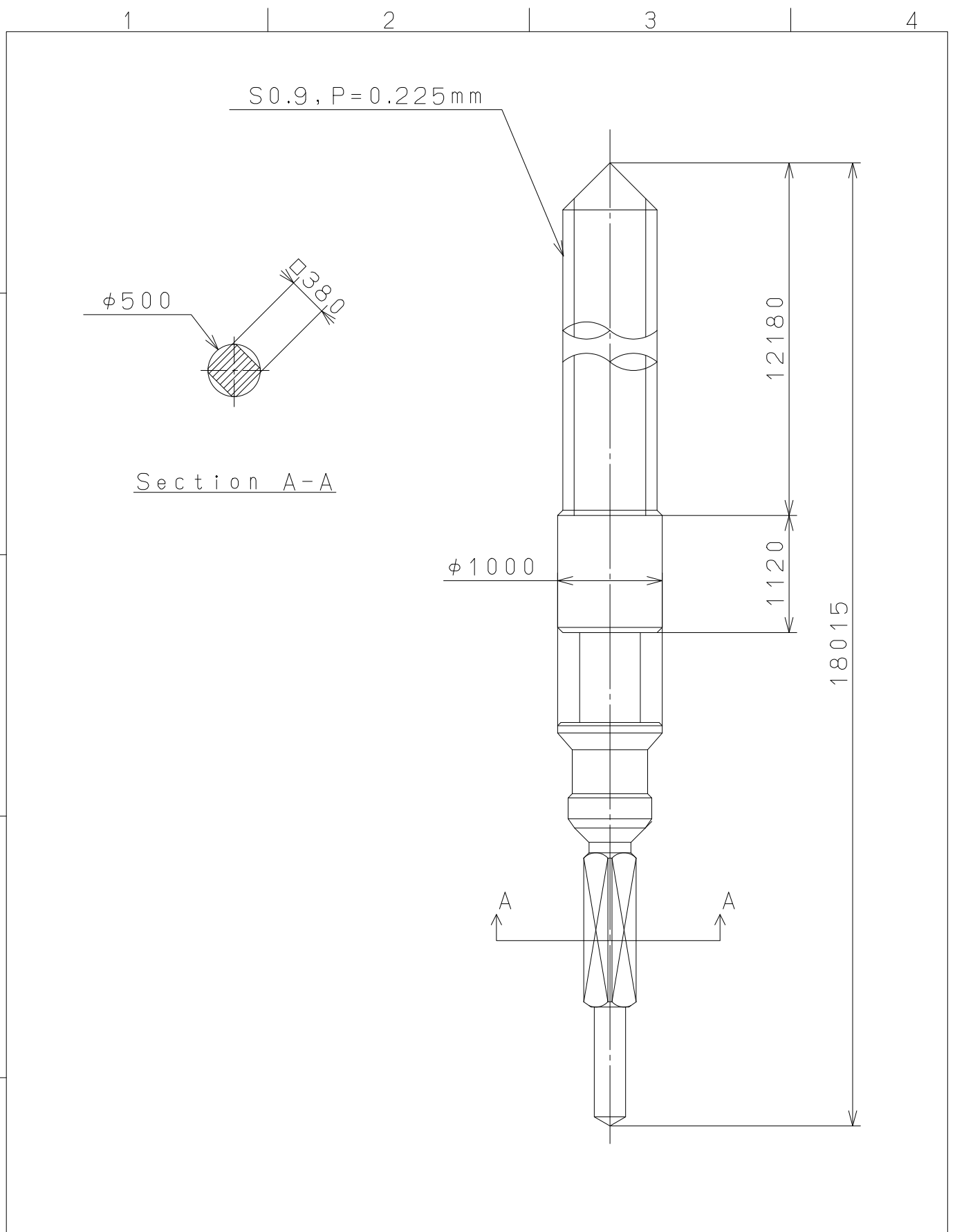

⑤			Quantity		Cal.NO.:
④			Unit	1/1000 <sub>mm</sub>	
③			Scale	20:1	Parts No.:
②			Date		065-379
①			Drawn		
Mark	Date	Description	Appro.	Checked	T.Hiruta
Alterations			Approved	Name:	
			SETTING STEM		
Material					Drawing No.:3790S000
Heat Treatment					<b>MIYOTA</b>
Hardness					
Plating					
			General Tolerances	CITIZEN WATCH CO.,LTD. TOKYO,JAPAN	
			Dimensions		
			Angles		