

This drawing is provisional and subject to our reconfirmation and/or revision without notice.

F E D C B A

Coordinates

記号	X	Y	R
GM	0	0	—
DH1	3000	13000	—
DH2	2100	-12800	—
a1	3441	14908	430
a2	1865	15186	430
a3	-15151	2129	430
a4	-15291	535	430
a5	10434	-11190	430
a6	9208	-12219	430

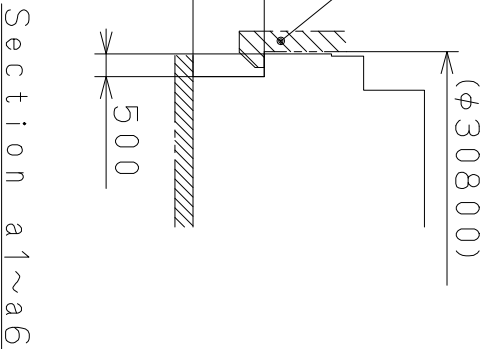
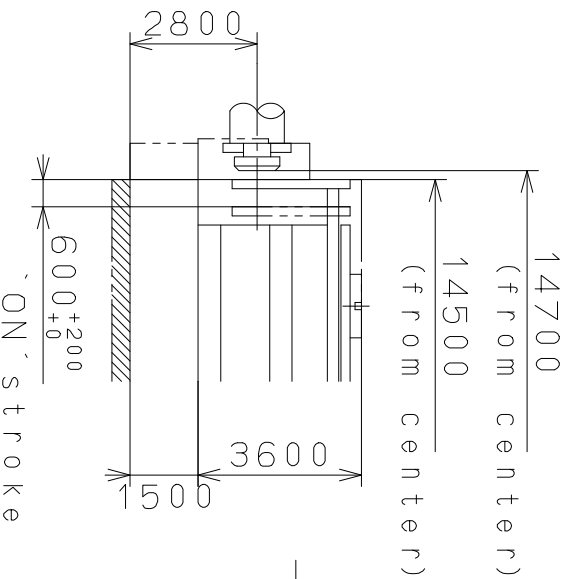
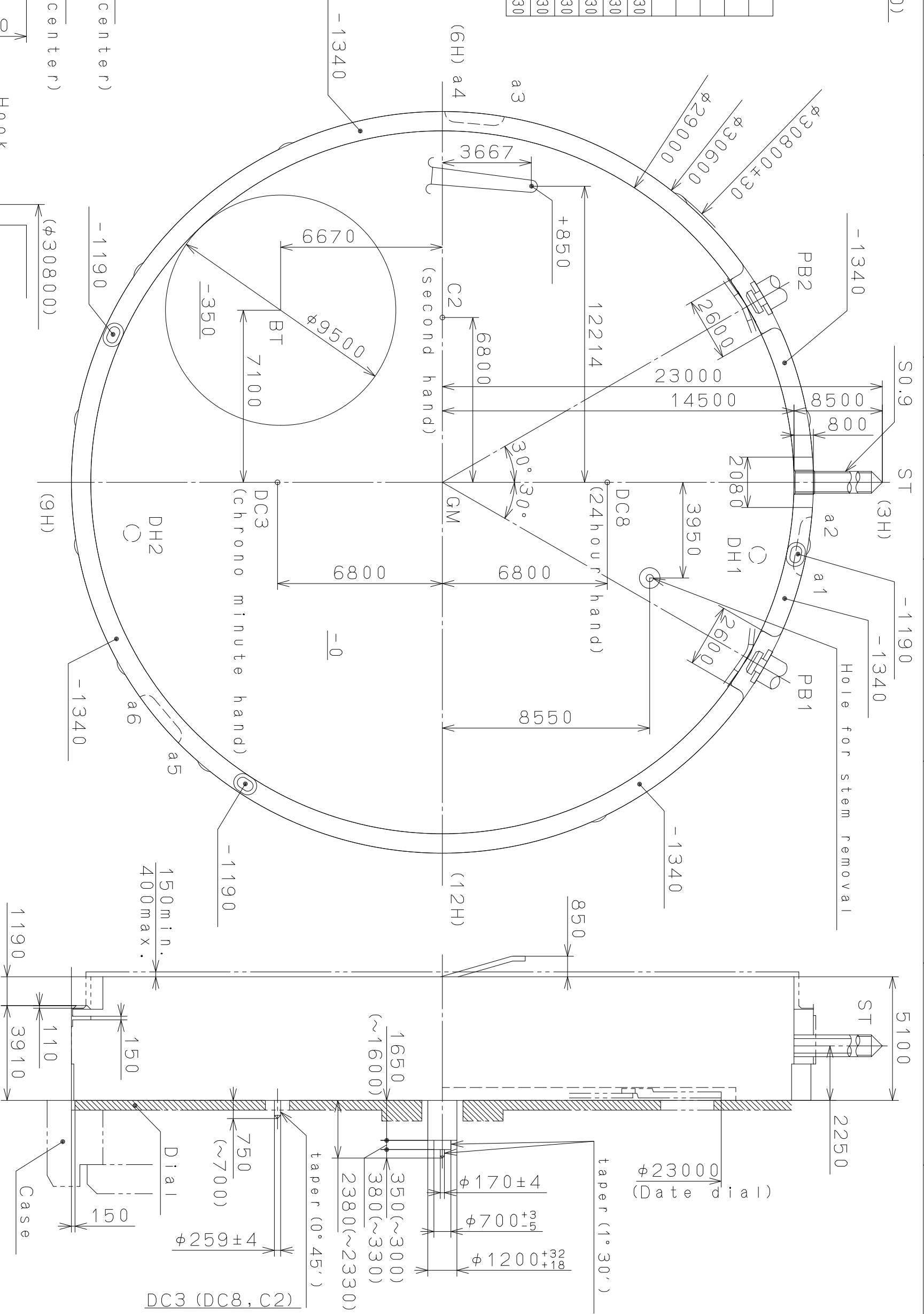

△	Quantity		Cal. NO.:	0S2B
△	Unit	1/1000 mm	Parts No.:	
△	Scale	6 : 1	Name:	Frame for Case
△	Date		Checked	N. Suzuki
△	Date		Drawn	
△	Alterations		Approved	
△	Date		Approval	
△	Description			
△	Material			
△	Heat Treatment			
△	Hardness			
△	Plating			
General Tolerances			Drawing No.: 0S2BC000	
Dimensions			miyotA	
Angles			CITIZEN WATCH CO., LTD. TOKYO, JAPAN	

This drawing is provisional and subject to our reconfirmation and/or revision without notice.

*** TIPW OS20-00A (01) *** (2100 1121) 01-01-80

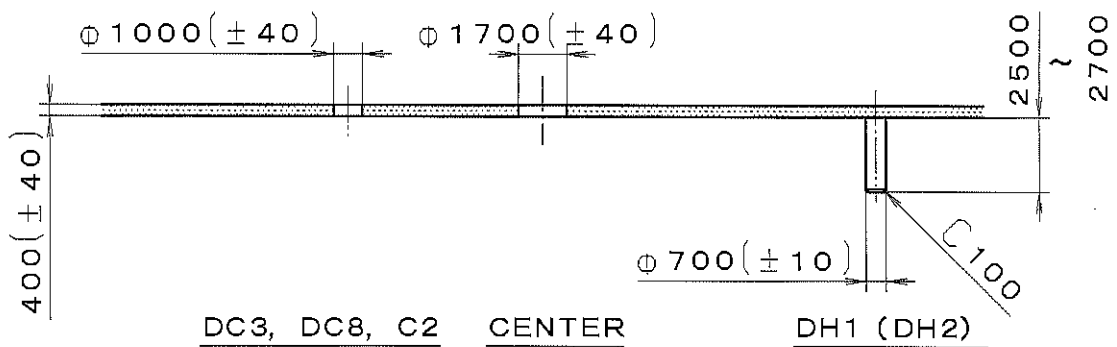
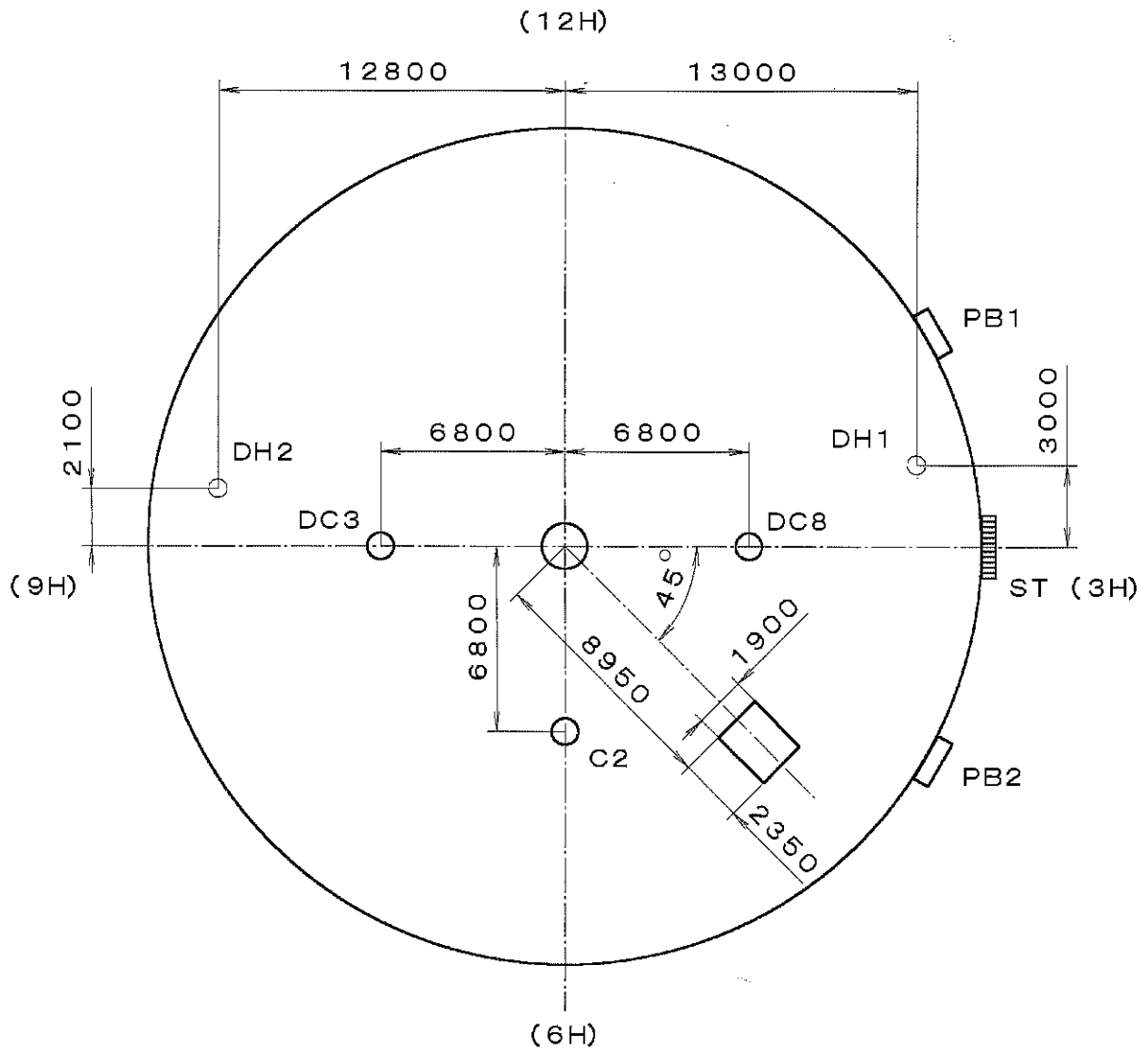

DC3, DC8, C2 CENTER

DH1 (DH2)

△		Quantity		Cal. No. : 0S2B-00A
△		Unit	1/1000 mm	
△		Scale	4:1	Parts:
△		Date		
△		Drawn		Name:
△		Checked	T. Hiruta	Indications for Dial
△		Approved		Drawing No. : OS20D000
Material				
Heat Treatment		General Tolerances		MIYOTA
Hardness		Dimensions		
Plating		Angles		

This drawing is provisional and subject to our reconfirmation and/or revision without notice.

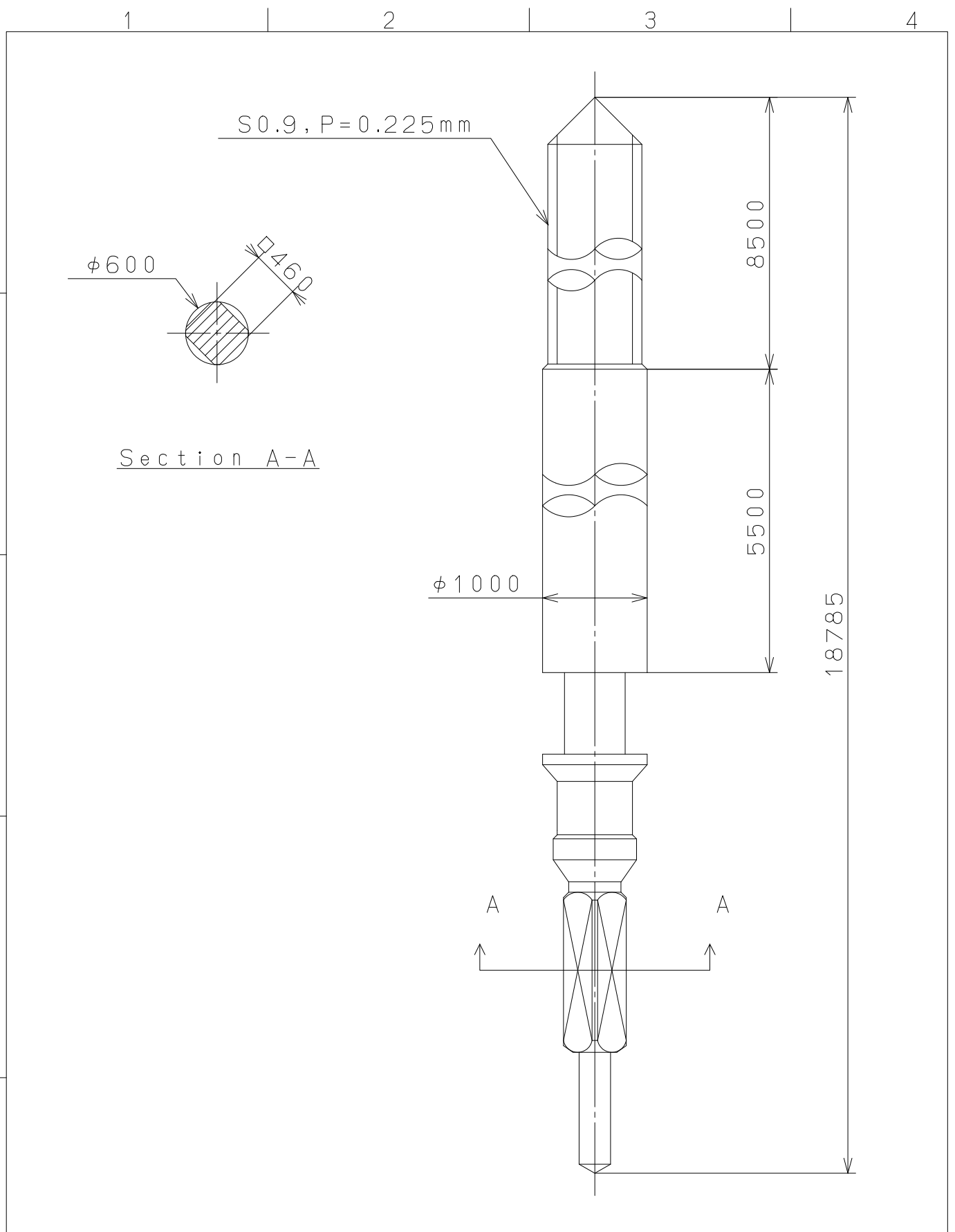

△5			Quantity		Cal.NO.:	
△4			Unit	1 / 1000 mm		
△3			Scale	20 : 1	Parts No.:	
△2			Date		065-453	
△1			Drawn			
Mark	Date	Description	Appr.	Checked	E. Murakami	Name:
Alterations			Approved	SETTING STEM		
Material					Drawing No.: 4530S000	
Heat Treatment					MIYOTA CITIZEN WATCH CO., LTD. TOKYO, JAPAN	
Hardness						
Plating						