

Coordinates		
記号	X	Y
GM	0	0
DH3	9298	-9298
DH4	-12192	4926

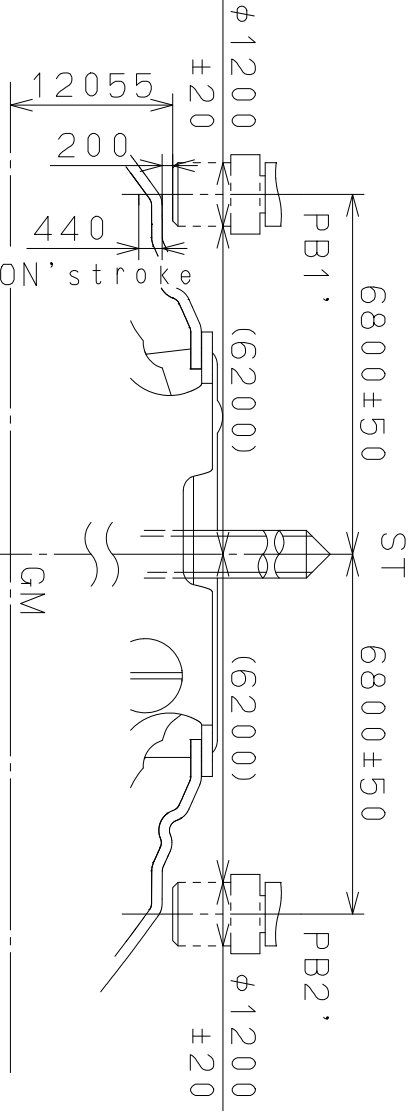
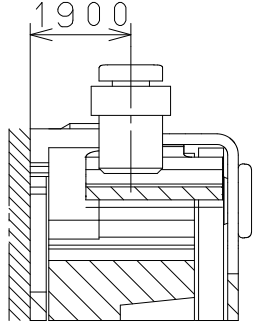
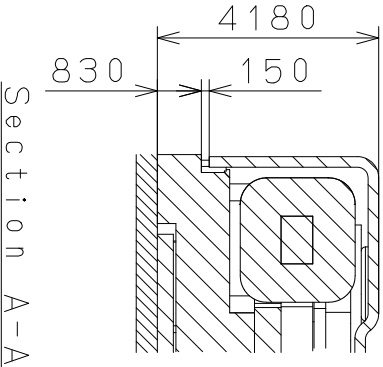
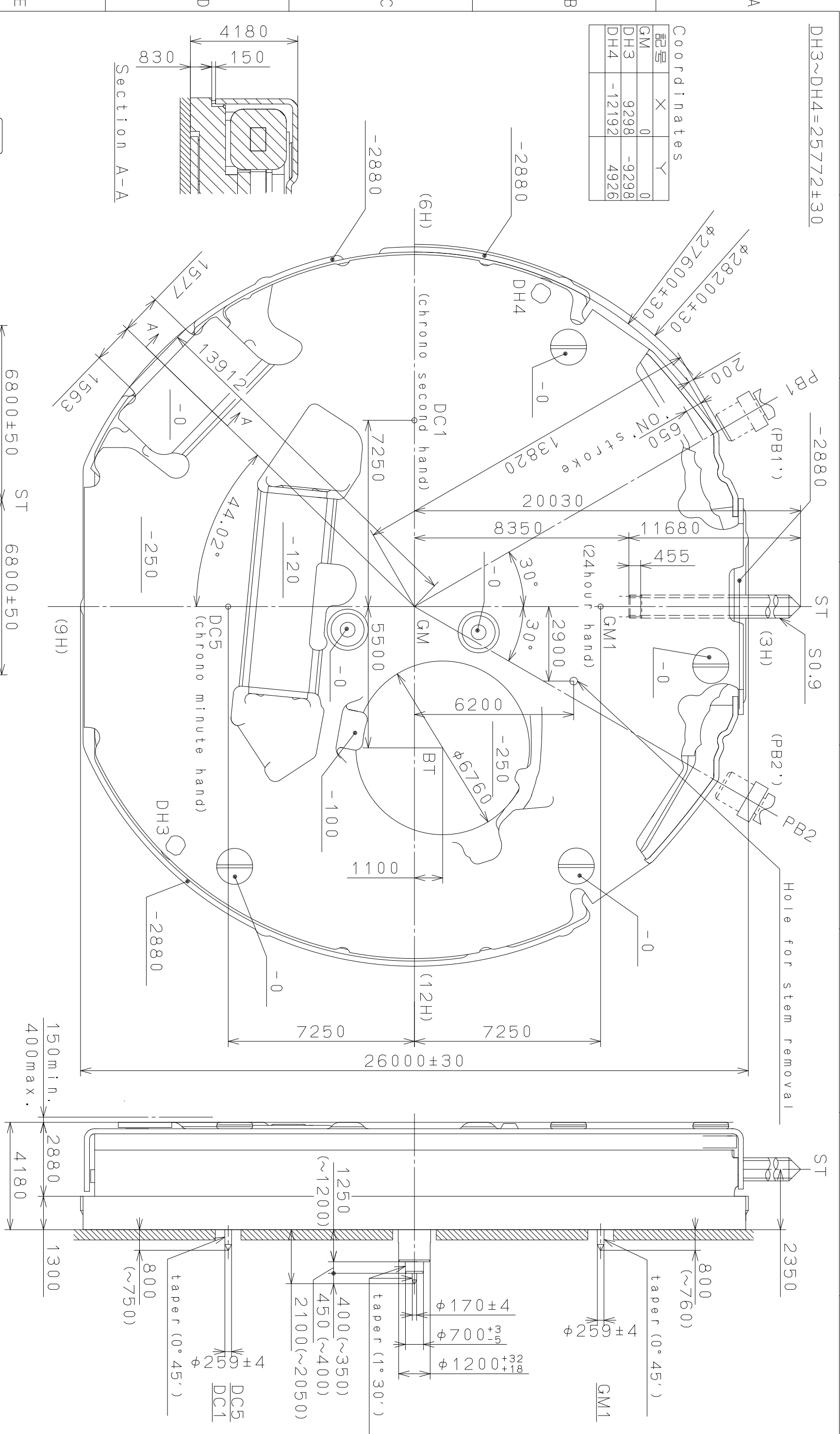

FOR PARALLEL PUSH BUTTON

△	Quantity	Cal. NO.:	JS20
△	Unit	Parts No.:	
△	Scale	Drawn	
△	Date	Checked	
△	Alterations	Approved	N. Suzuki
Material		Name: Frame for Case	
Heat Treatment		Drawing No.: JS20C001	
Hardness		General Tolerances	
Plating		Dimensions	
		Angles	

MIYOTA
CITIZEN WATCH CO., LTD. TOKYO, JAPAN

This drawing is provisional and subject to our reconfirmation and/or revision without notice.

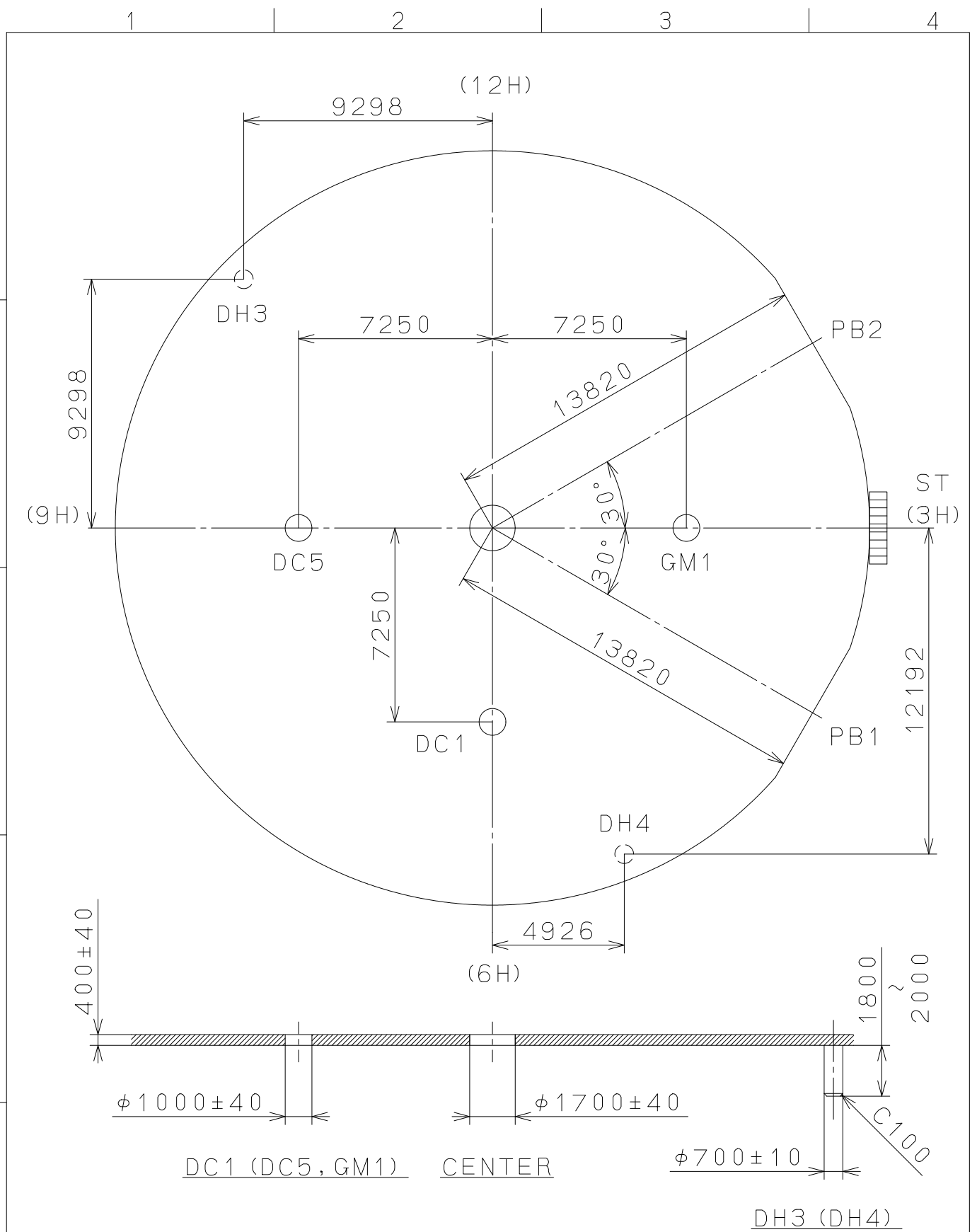

△			Quantity		Cal.NO.:
△			Unit	1/1000 _{mm}	JS20-00C
△			Scale	5 : 1	Parts No.:
△			Date		
△			Drawn		
Mark	Date	Description	Appr.	Checked	Name:
		Alterations	Approved	N. Suzuki	Indications for Dial
Material					Drawing No.: JS20D001
Heat Treatment			General Tolerances		MIYOTA
Hardness			Dimensions		
Plating			Angles		
					CITIZEN WATCH CO., LTD. TOKYO, JAPAN

2006/12/25 (07:50:10)

This drawing is provisional and subject to our reconfirmation and/or revision without notice.

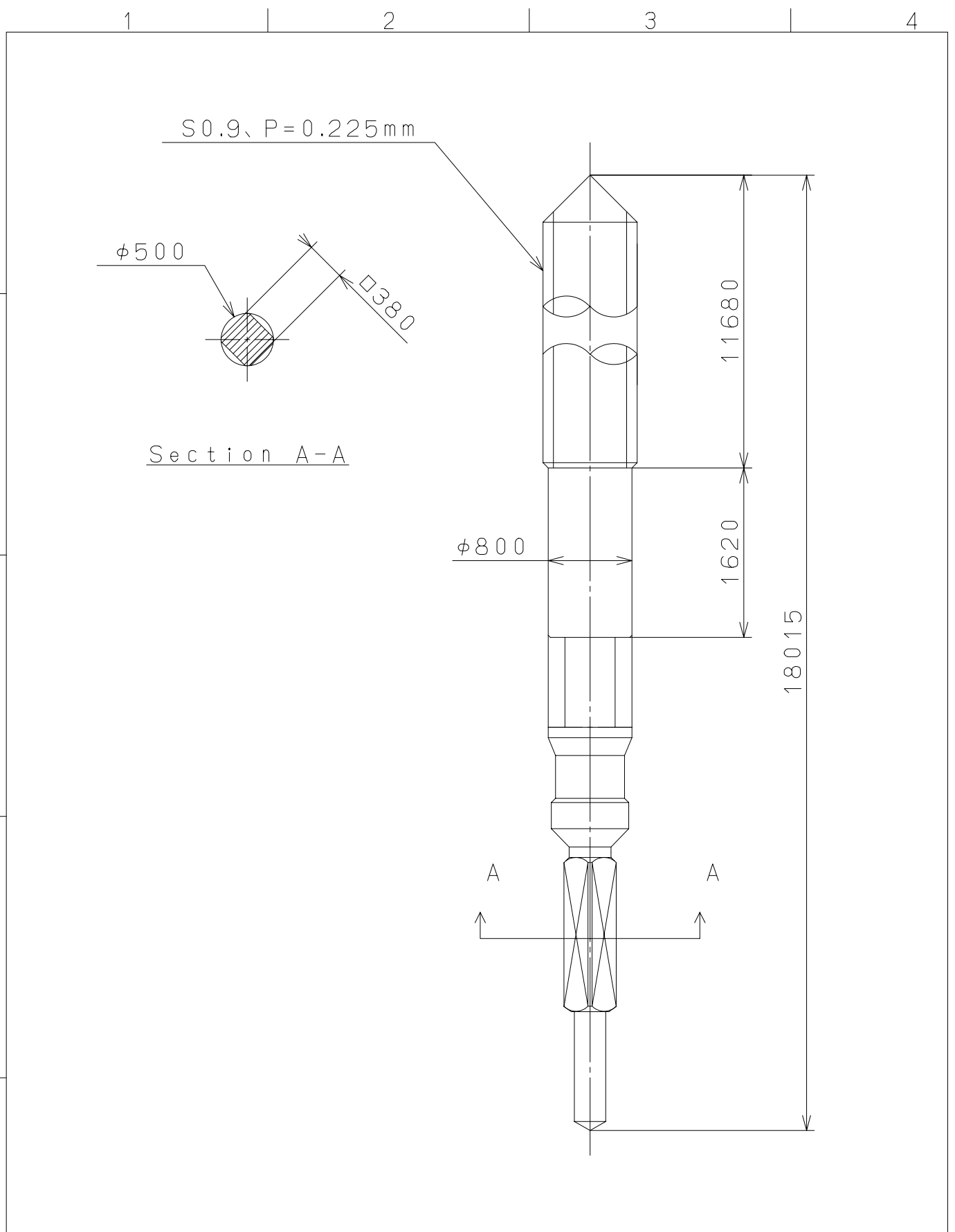

⑤			Quantity		Cal.NO.:
④			Unit	1 / 1000 mm	
③			Scale	20 / 1	Parts No.:
②			Date		065-505
①			Drawn		Name:
Mark	Date	Description	Appr.	Checked	T.Hiruta
Alterations			Approved	SETTING STEM	
Material				Drawing No.: 5050S000	
Heat Treatment				General Tolerances	
Hardness				Dimensions	
Plating				Angles	
				MIYOTA	
				CITIZEN WATCH CO., LTD. TOKYO, JAPAN	