

This drawing is provisional and subject to our reconfirmation and/or revision without notice.

F E D C B A 1 2 3 4 5 6 7 8

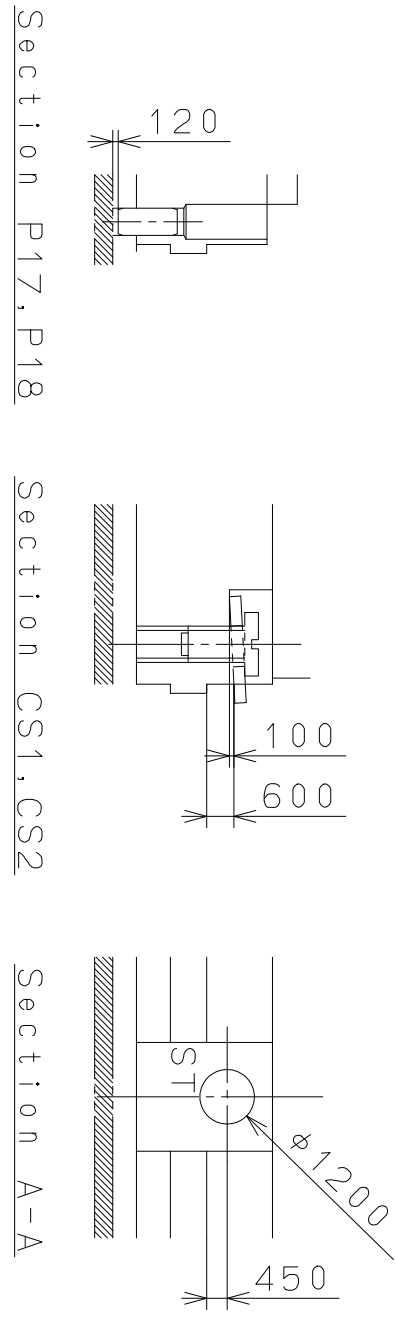
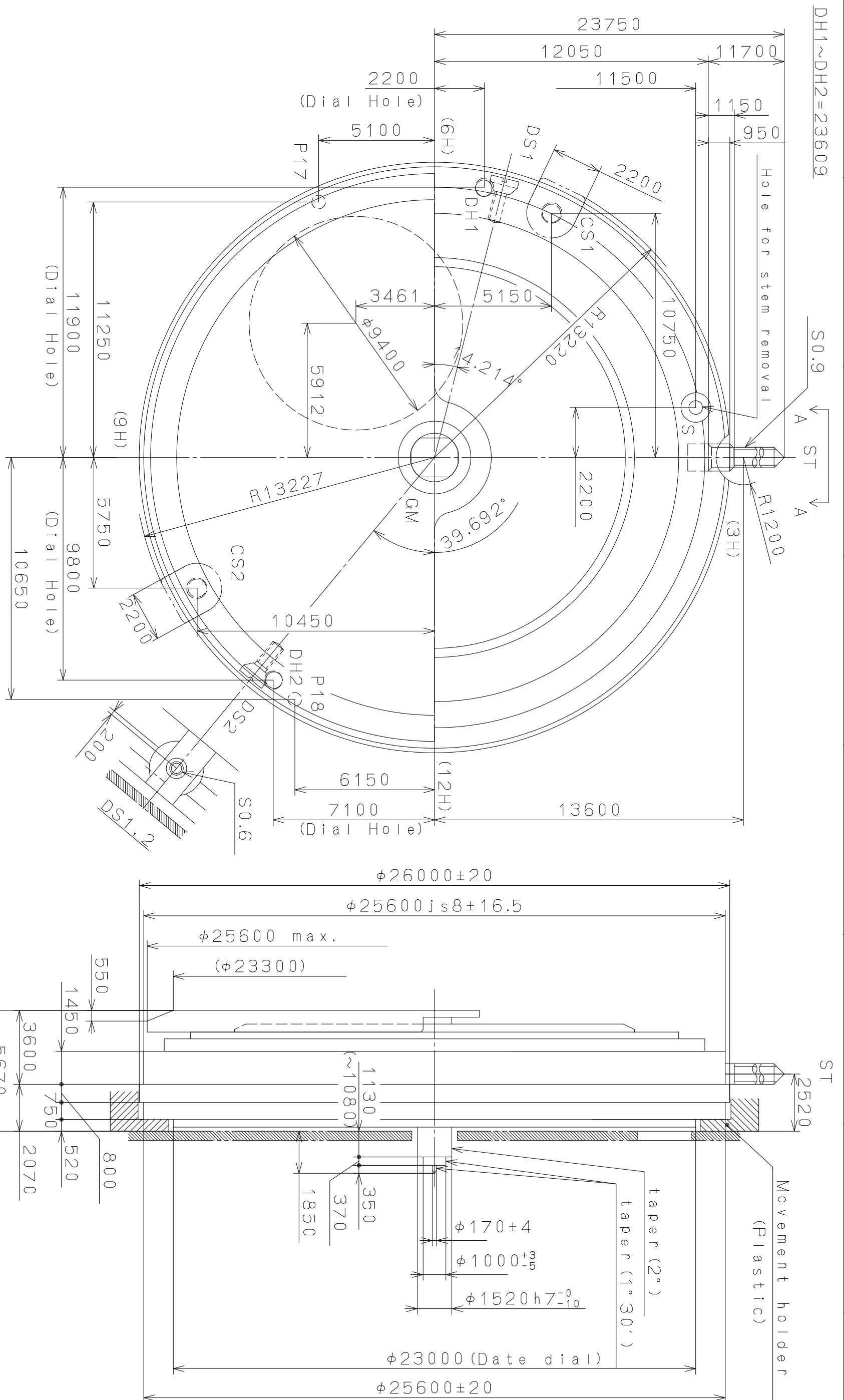

Material	Alterations	Mark	Date	Description	Appro.	Checked	M. Kobayashi	Name:	Frame for Case
Heat Treatment									Drawing No.: 8215C013
Hardness									
Plating									
Quantity	Unit	Scale	Date	Drawn	Approved			Cal. NO.:	8215
	1/1000 mm	6 : 1						Parts No.:	
General Tolerances									
Dimensions									
Angles									

MIYOTA
CITIZEN WATCH CO., LTD. TOKYO, JAPAN

This drawing is provisional and subject to our reconfirmation and/or revision without notice.

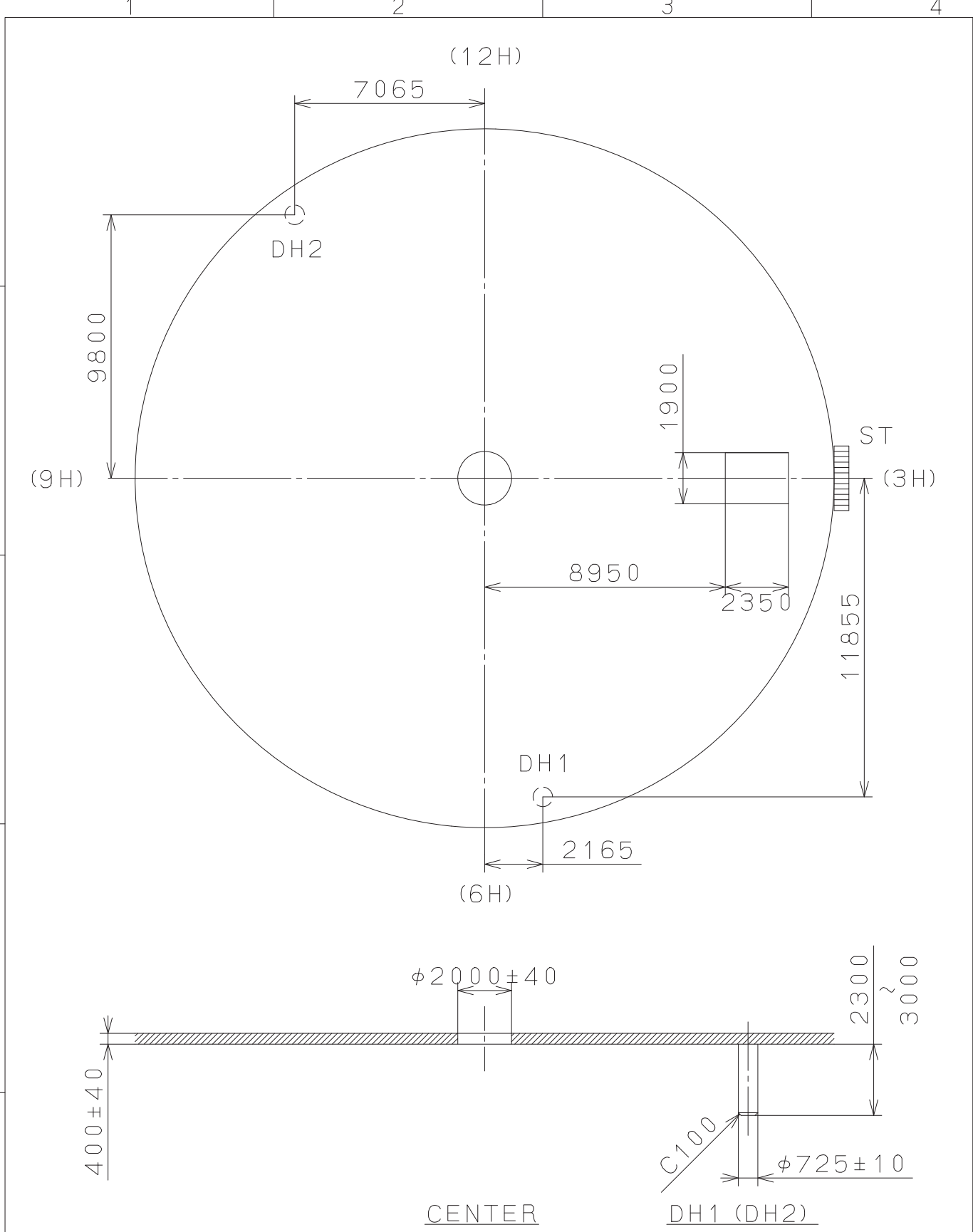

△5			Quantity		Cal. NO.:	8215-21A
△4			Unit	1 / 1000 mm		
△3			Scale	5 : 1	Parts No.:	
△2			Date			
△1			Drawn			
Mark	Date	Description	Appr.	Checked	M. Kobayashi	Name:
Alterations			Approved			Indications for Dial
Material					Drawing No.: 821AD000	
Heat Treatment						
Hardness						
Plating						
			General Tolerances	CITIZEN WATCH CO., LTD. TOKYO, JAPAN		
			Dimensions			
			Angles			

2008/11/14 (11:30:42)

This drawing is provisional and subject to our reconfirmation and/or revision without notice.

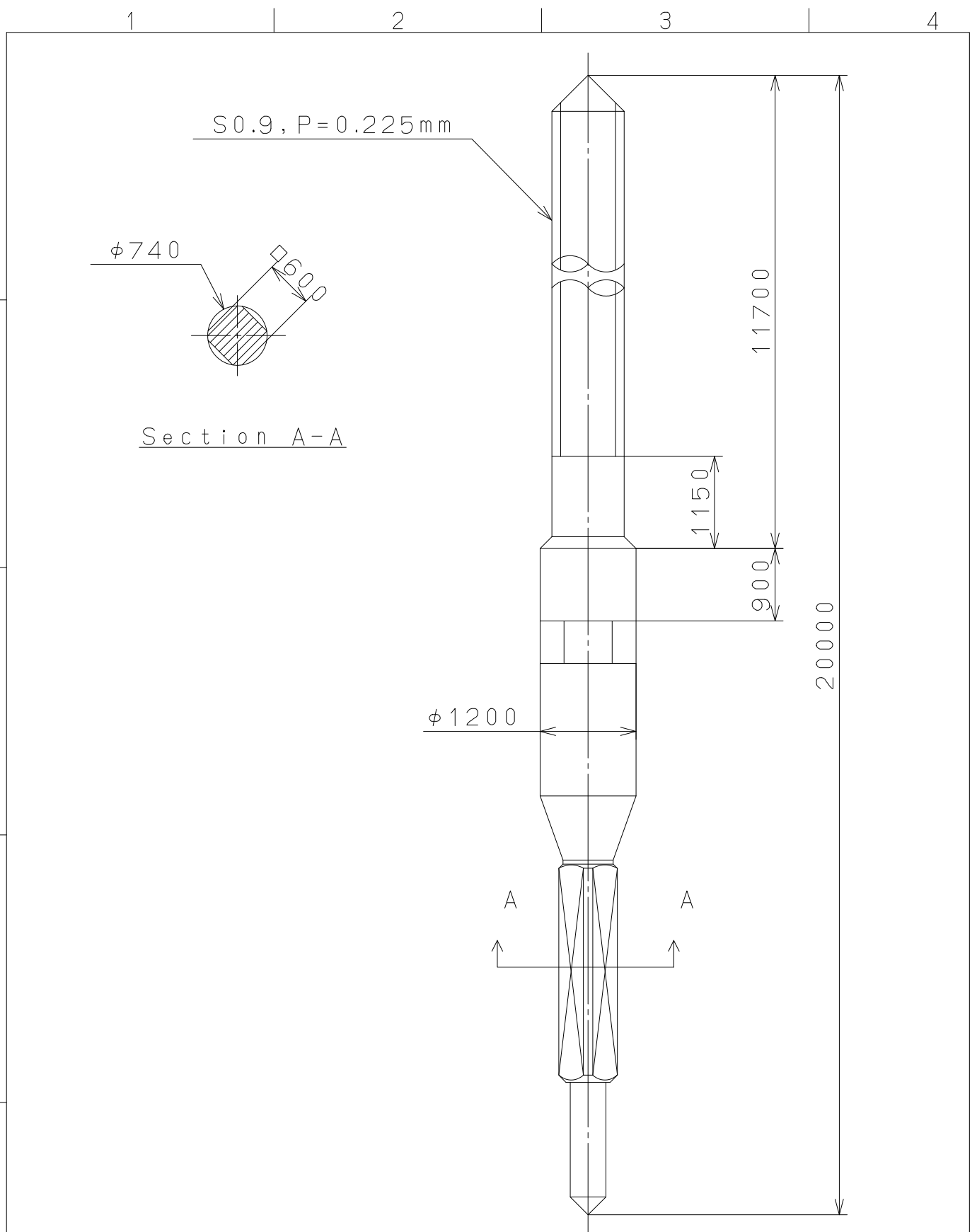

△			Quantity		Cal.NO.:
△			Unit	1/1000mm	
△			Scale	15:1	Parts No.:
△			Date		065-212
△			Drawn		
Mark	Date	Description	Appr.	Checked	Name:
		Alterations	Approved	N. Suzuki	SETTING STEM
Material					Drawing No.: 2120S001
Heat Treatment			General Tolerances	MIYOTA CITIZEN WATCH CO., LTD. TOKYO, JAPAN	
Hardness			Dimensions		
Plating			Angles		

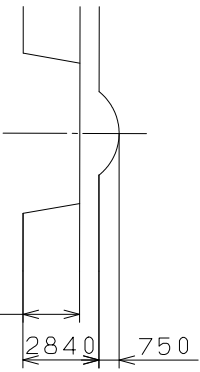
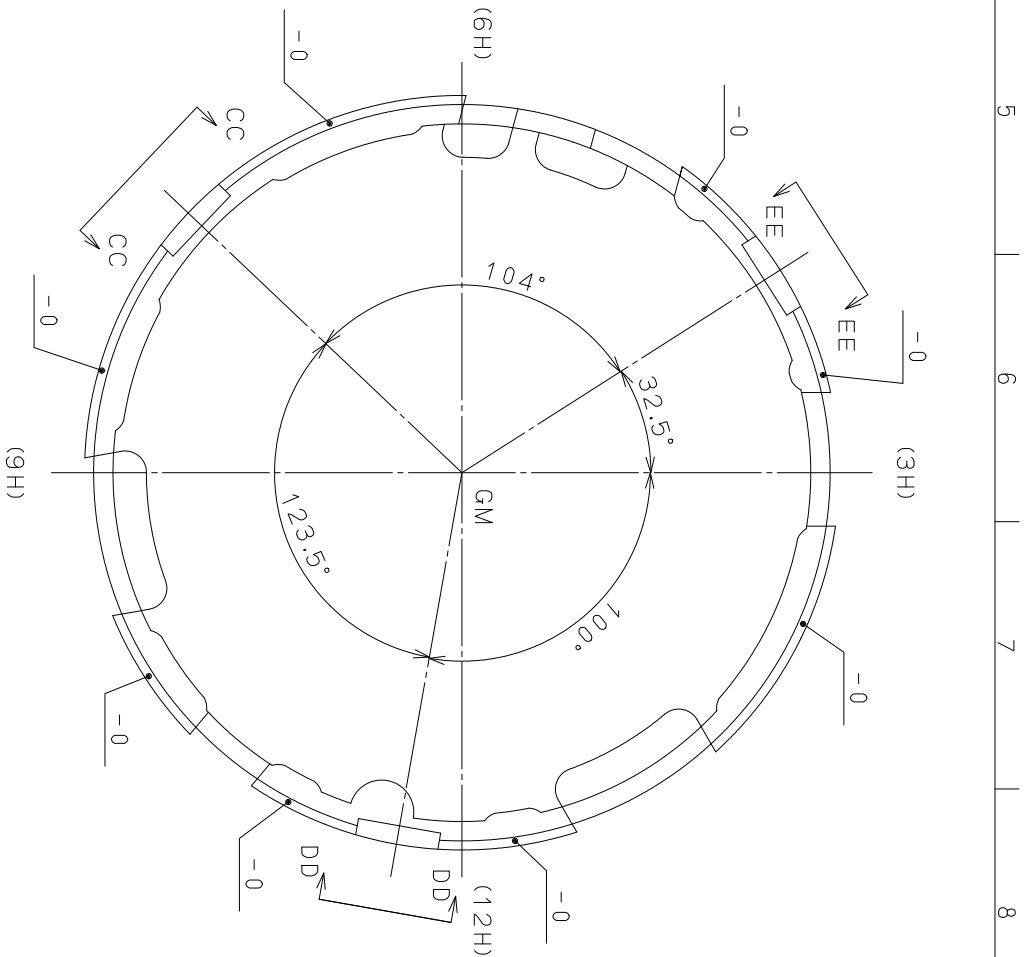
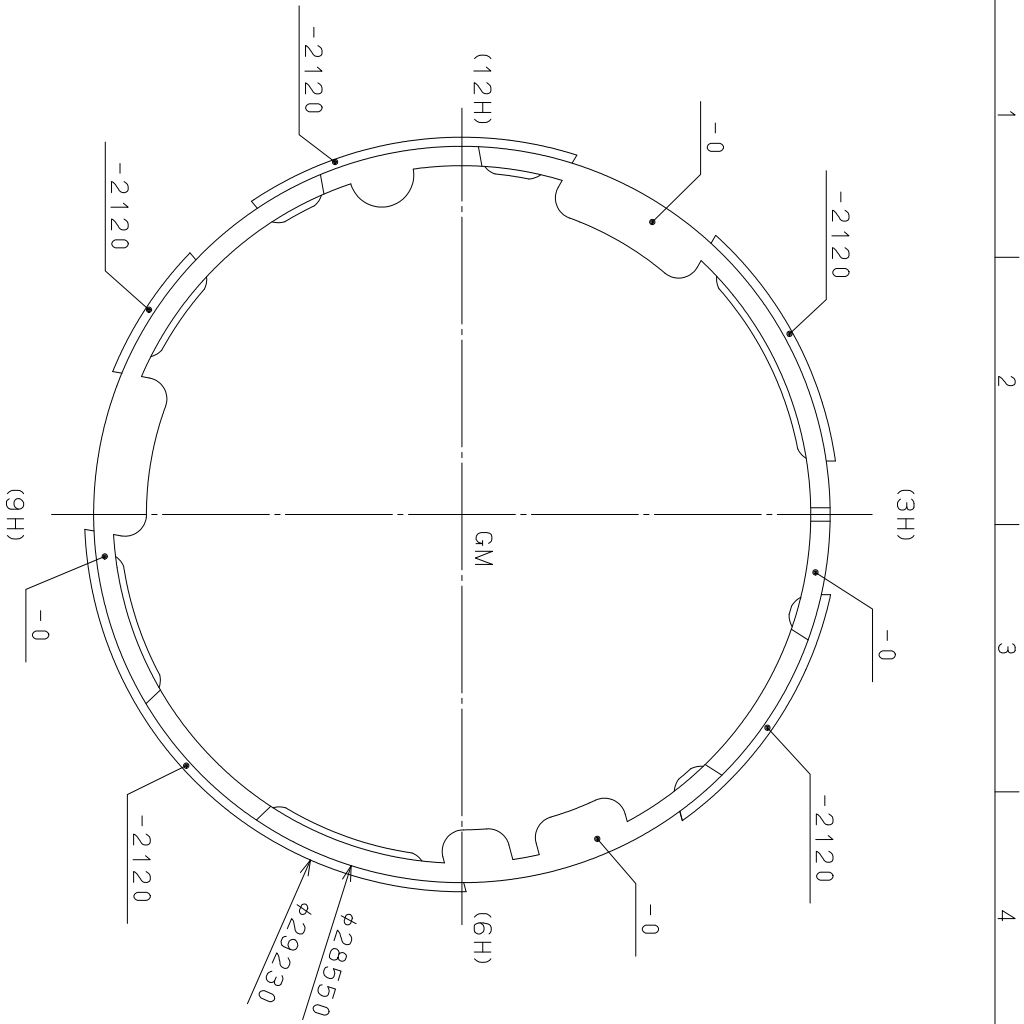

View CC-CC
DD-DD, EE-EE

△	Quantity	1/1000 mm	Call. NO.:
△	Unit	5 : 1	Parts No.:
△	Scale	Drawn	500-710
△	Date	Checked	Name:
△	Mark	Approved	N. Suzuki
△	Date	Approved	Casing Holder
△	Material	Alterations	Drawing No.: 8200E003
△	Heat Treatment	General Tolerances	MIYOTA
△	Hardness	Dimensions	
△	Plating	Angles	
			CITIZEN WATCH CO., LTD. TOKYO, JAPAN