

This drawing is provisional and subject to our reconfirmation and/or revision without notice.

DH1~DH2=16171 (±20)

Mark	X	Y	R
GM	0	0	—
DH1	-7900	-3000	—
DH2	8234	-1900	—
a1	-7569	-3828	300
a2	-7252	-4215	200
a3	-5914	-5092	200
a4	-5433	-5228	300
a5	4625	-5757	300
a6	5106	-5621	200
a7	6444	-4745	200
a8	6761	-4358	300
a9	4947	5546	300
a10	4628	6054	300
a11	2754	7083	300
a12	2157	7026	300

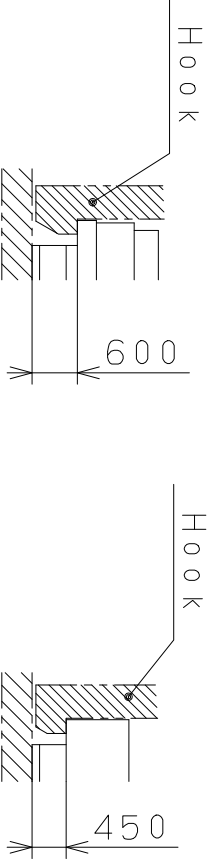
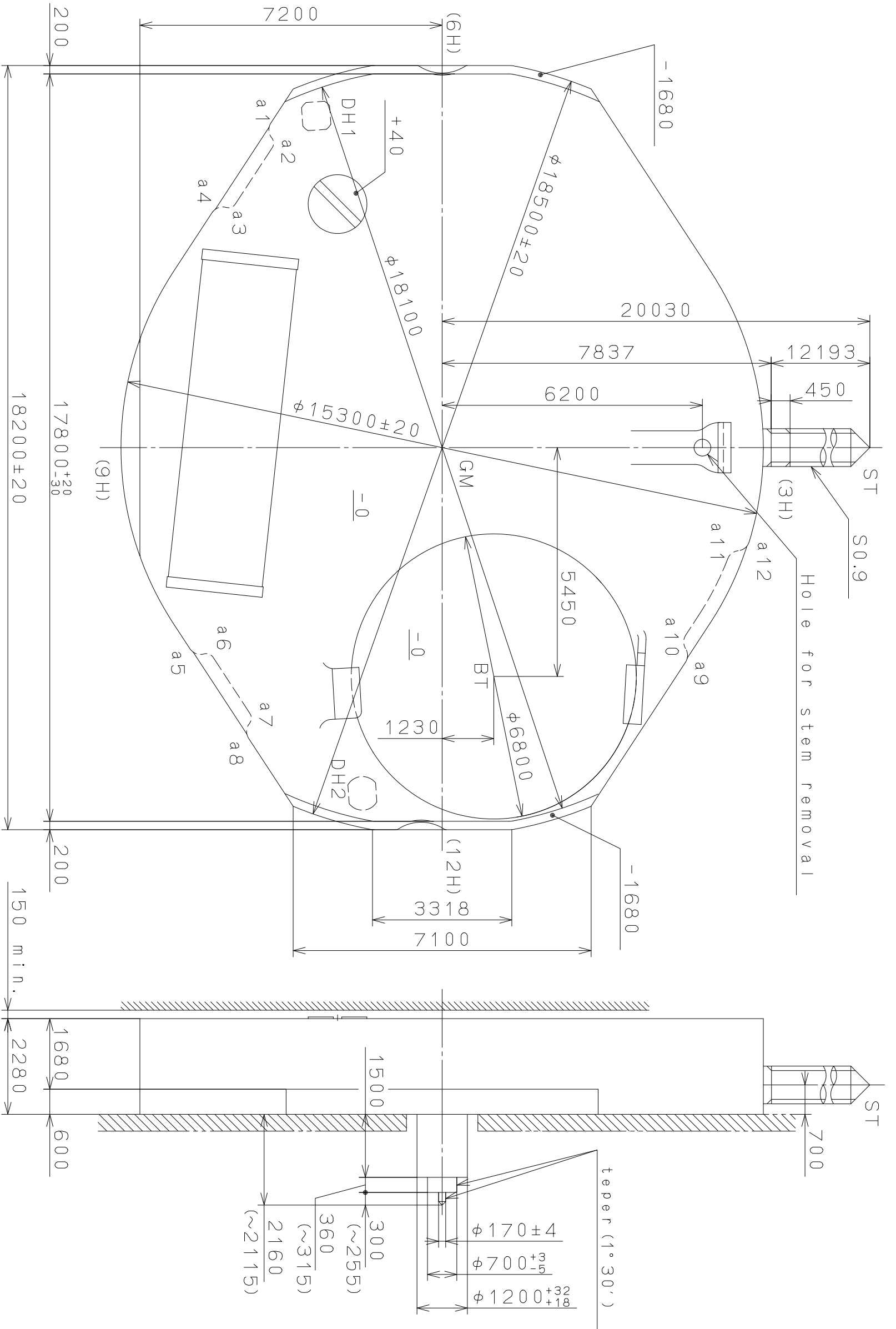

Section a1~a4, a5~a8

Section a9~a12

Mark	Date	Description	Appr.	Checked	Drawn	Name:
Alterations						N. Suzuki Name: Frame for Case Drawing No.: GL36C000
Material						
Heat Treatment						
Hardness						
Plating						
General Tolerances				Dimensions		
Angles				Angles		

Cal. NO.: GL34

Unit: 1/1000 mm

Scale: 10:1

Parts No.:

**MIYOTA**

CITIZEN WATCH CO., LTD. TOKYO, JAPAN

This drawing is provisional and subject to our reconfirmation and/or revision without notice.

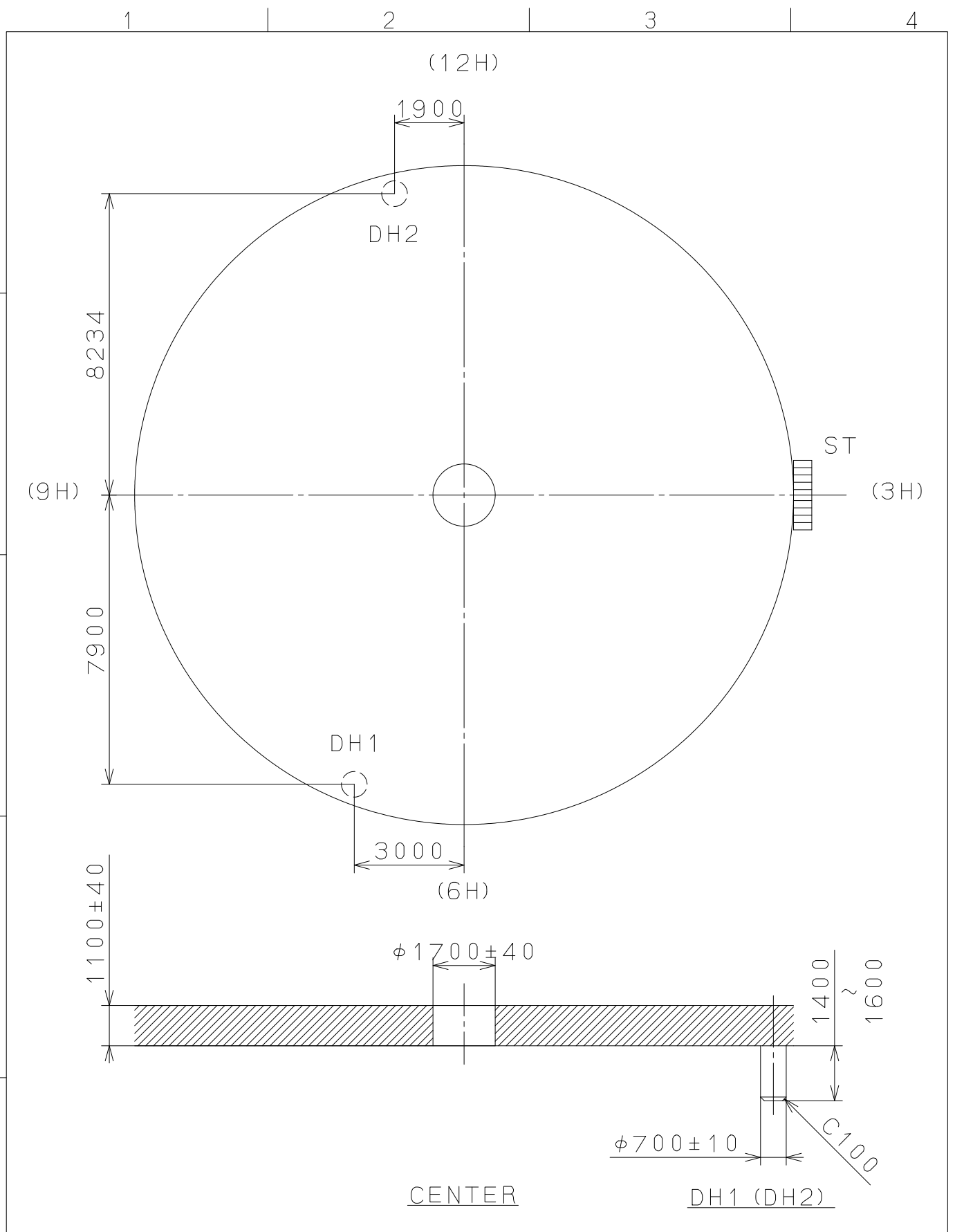

△5			Quantity		Cal. NO.	GL34-10A
△4			Unit	1 / 1000 mm	Parts No.:	
△3			Scale	7 : 1		
△2			Date			
△1			Drawn			
Mark	Date	Description	Appr.	Checked	N. Suzuki	Name:
Alterations			Approved			Indications for Dial
Material					Drawing No.: GL36D0AS	
Heat Treatment					<b>MIYOTA</b> CITIZEN WATCH CO., LTD. TOKYO, JAPAN	
Hardness						
Plating						

This drawing is provisional and subject to our reconfirmation and/or revision without notice.

\*\*\* T I P W 065-541 (01) \*\*\* (2100 1121) 02-07-12

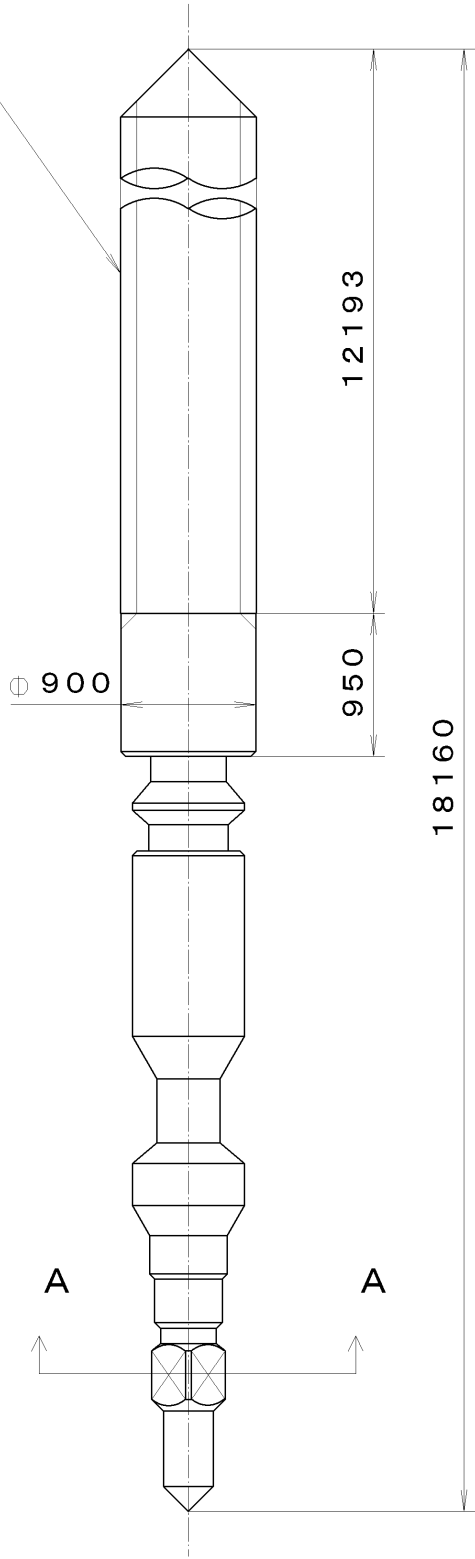
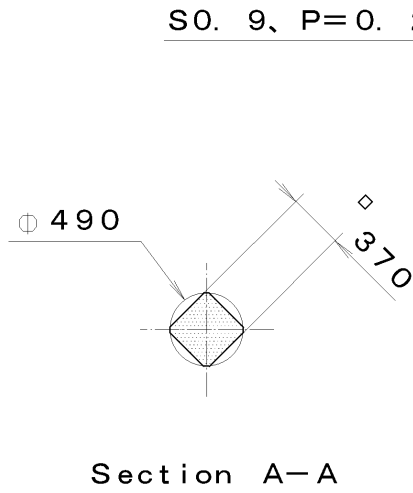

7				Quantity		Cal. No. :	
6				Unit	1/1000 mm	Parts:	065-541
5				Scale	20:1		
4				Date		Name:	SETTING STEM
3				Drawn			
2				Checked	T. Hiruta	Drawing No. : 5410S000	
1				Approved			
Material							
Heat Treatment				General Tolerances		<div style="font-size: 2em; font-weight: bold; margin-bottom: 5px;">CITIZEN</div> WATCH CO., LTD. TOKYO, JAPAN	
Hardness				Dimensions			
Plating				Angles			