

This drawing is provisional and subject to our reconfirmation and/or revision without notice.

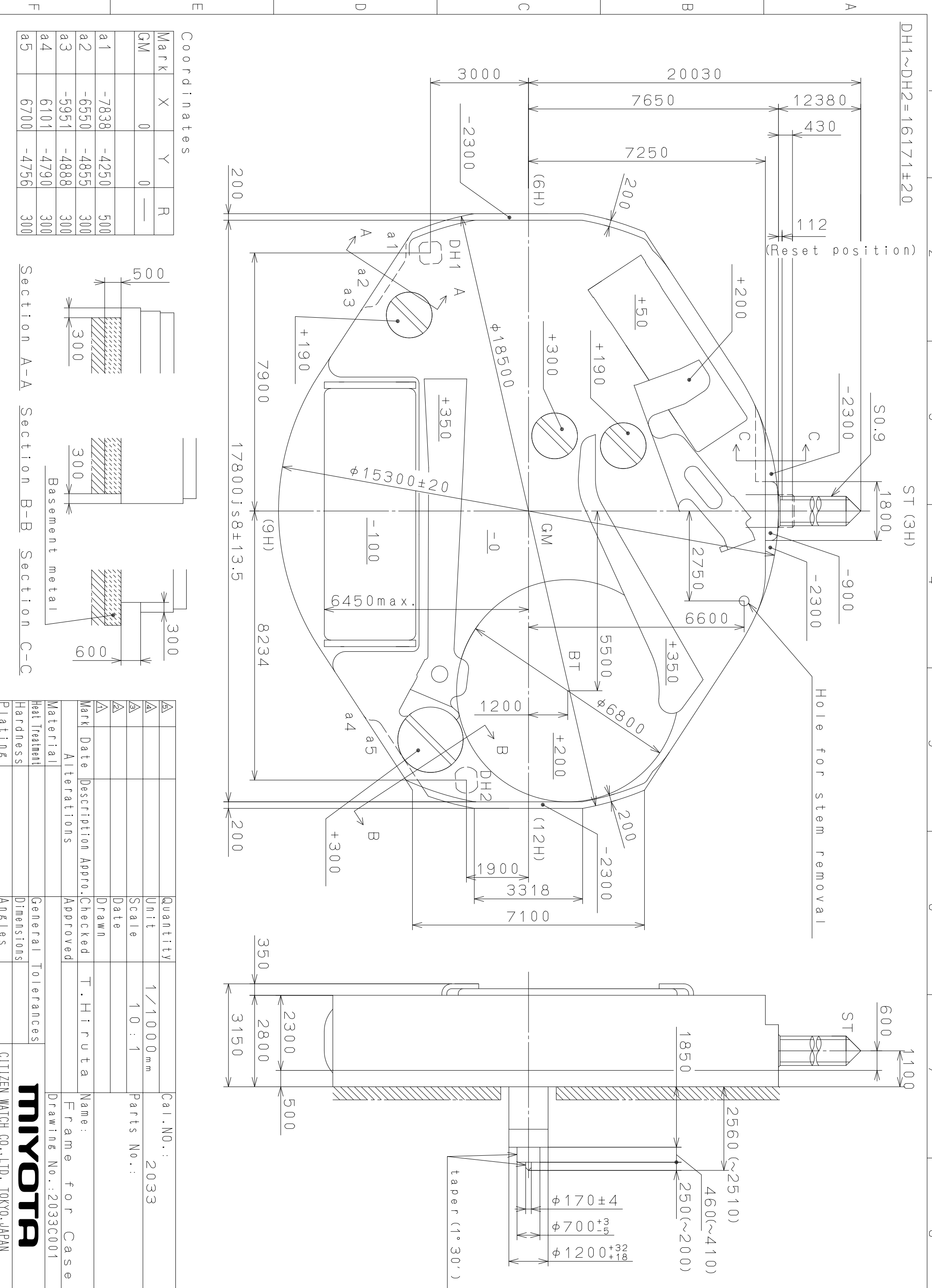

Coordinates

Mark	X	Y	R
GM	0	0	—
a1	-7838	-4250	500
a2	-6550	-4855	300
a3	-5951	-4888	300
a4	6101	-4790	300
a5	6700	-4756	300

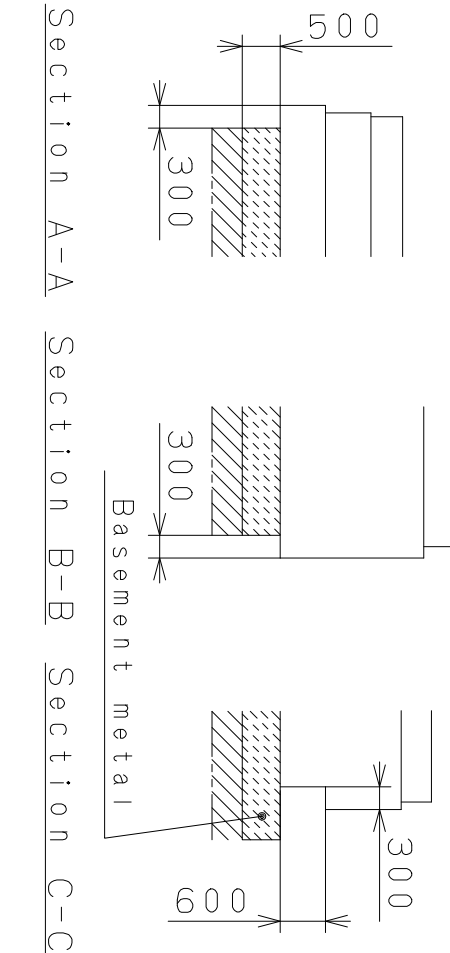

Mark	Date	Description	Appr.	Checked	Drawn	Quantity	Unit	Scale	Parts No.:
△5						1	1/1000 mm	10:1	2033
△4									
△3									
△2									
△1									
Material	Alterations		Approved	T. Hiruta		Name: Frame for Case			
Heat Treatment						Drawing No.: 2033C001			
Hardness						General Tolerances			
Plating						Dimensions			
						Angles			

Cal. NO.: 2033
 Parts No.:
 Name: Frame for Case
 Drawing No.: 2033C001
MIYOTA
 CITIZEN WATCH CO., LTD. TOKYO, JAPAN

This drawing is provisional and subject to our reconfirmation and/or revision without notice.

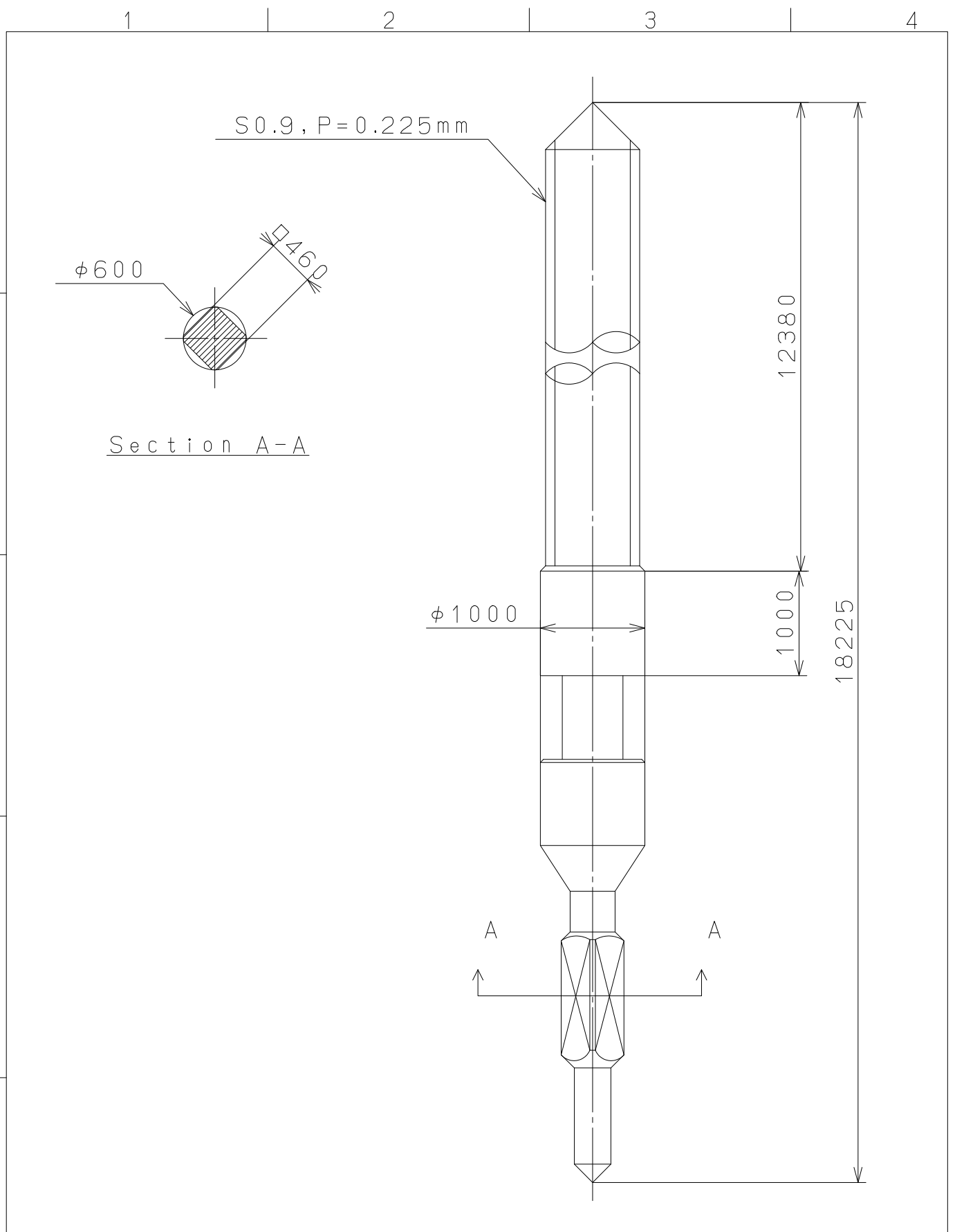

△5			Quantity		Cal.NO.:
△4			Unit	1 / 1000 mm	
△3			Scale	20 : 1	Parts No.:
△2			Date		065-468
△1			Drawn		
Mark	Date	Description	Appro.	Checked	M. Kobayashi
Alterations			Approved	Name: SETTING STEM	
Material					Drawing No.: 4680S001
Heat Treatment					MIYOTA CITIZEN WATCH CO., LTD. TOKYO, JAPAN
Hardness					
Plating					