

Coordinates		
Mark	X	Y
GM	0	0
DH11	9359	-9359
DH12	-12271	4958

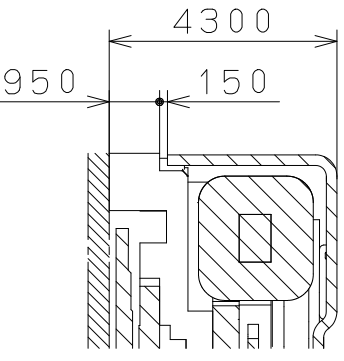
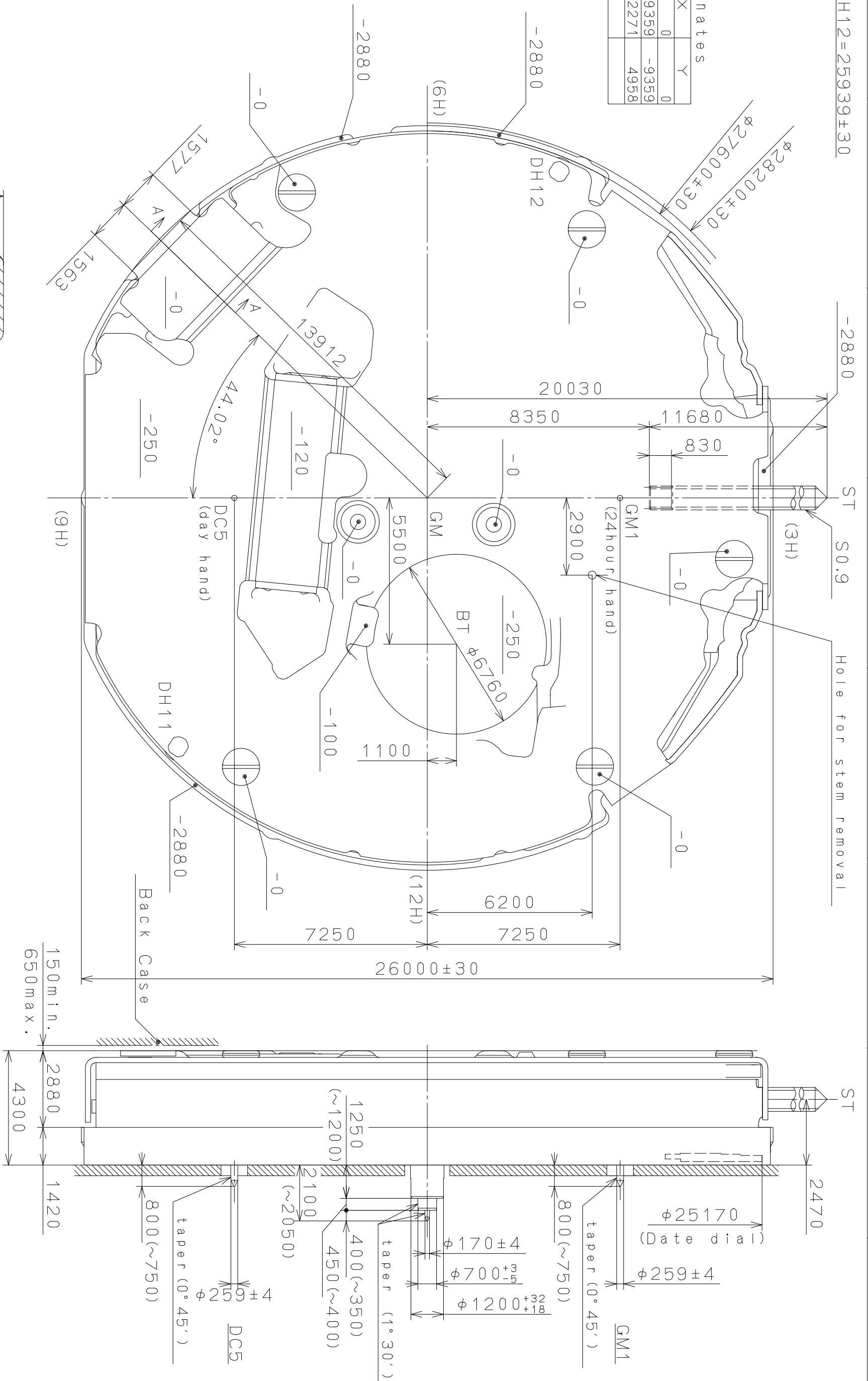

Section A-A

Quantity	Unit	Cal. NO.:
1	1/1000 mm	JP21
7	7 : 1	Parts No.:
Date		
Drawn		
Checked		
Appro. M. Kobayashi		
Name: Frame for Case		
Drawing No.: JP21C000		
Material		
Heat Treatment		
Hardness		
Plating		
General Tolerances		
Dimensions		
Angles		

**MIYOTA**

CITIZEN WATCH CO., LTD. TOKYO, JAPAN

This drawing is provisional and subject to our reconfirmation and/or revision without notice.

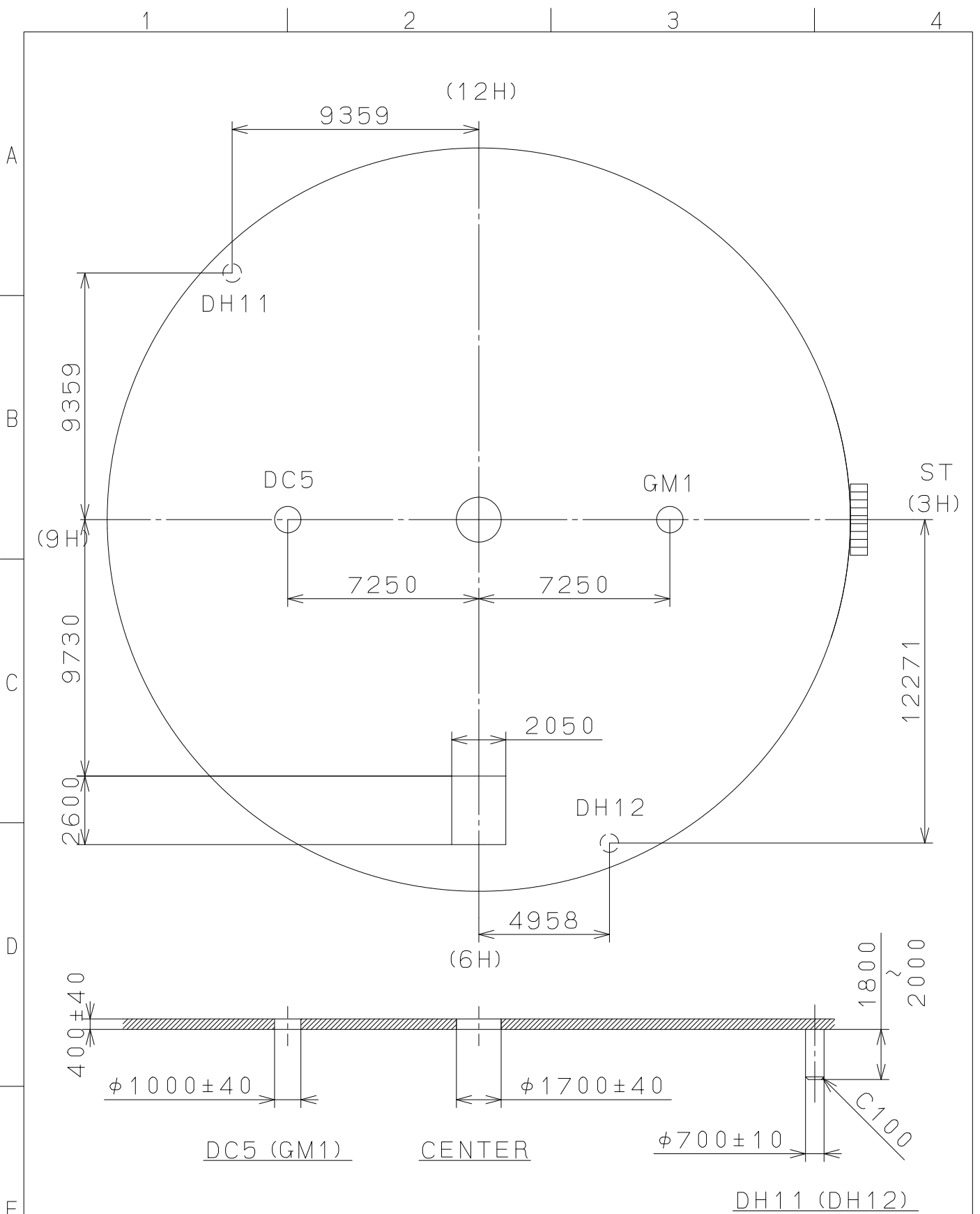

△			Quantity		Cal.NO.:
△			Unit	1/1000 <sub>mm</sub>	JP21-00C
△			Scale	5 : 1	Parts No.:
△			Date		
△			Drawn		
Mark	Date	Description	Appro.	Checked	M. Kobayashi
Alterations			Approved	Name:	
Material				Indications for Dial	
Heat Treatment				Drawing No.: JP21D000	
Hardness				<b>MIYOTA</b> CITIZEN WATCH CO., LTD. TOKYO, JAPAN	
Plating					

2006/12/25 (07:50:10)

This drawing is provisional and subject to our reconfirmation and/or revision without notice.

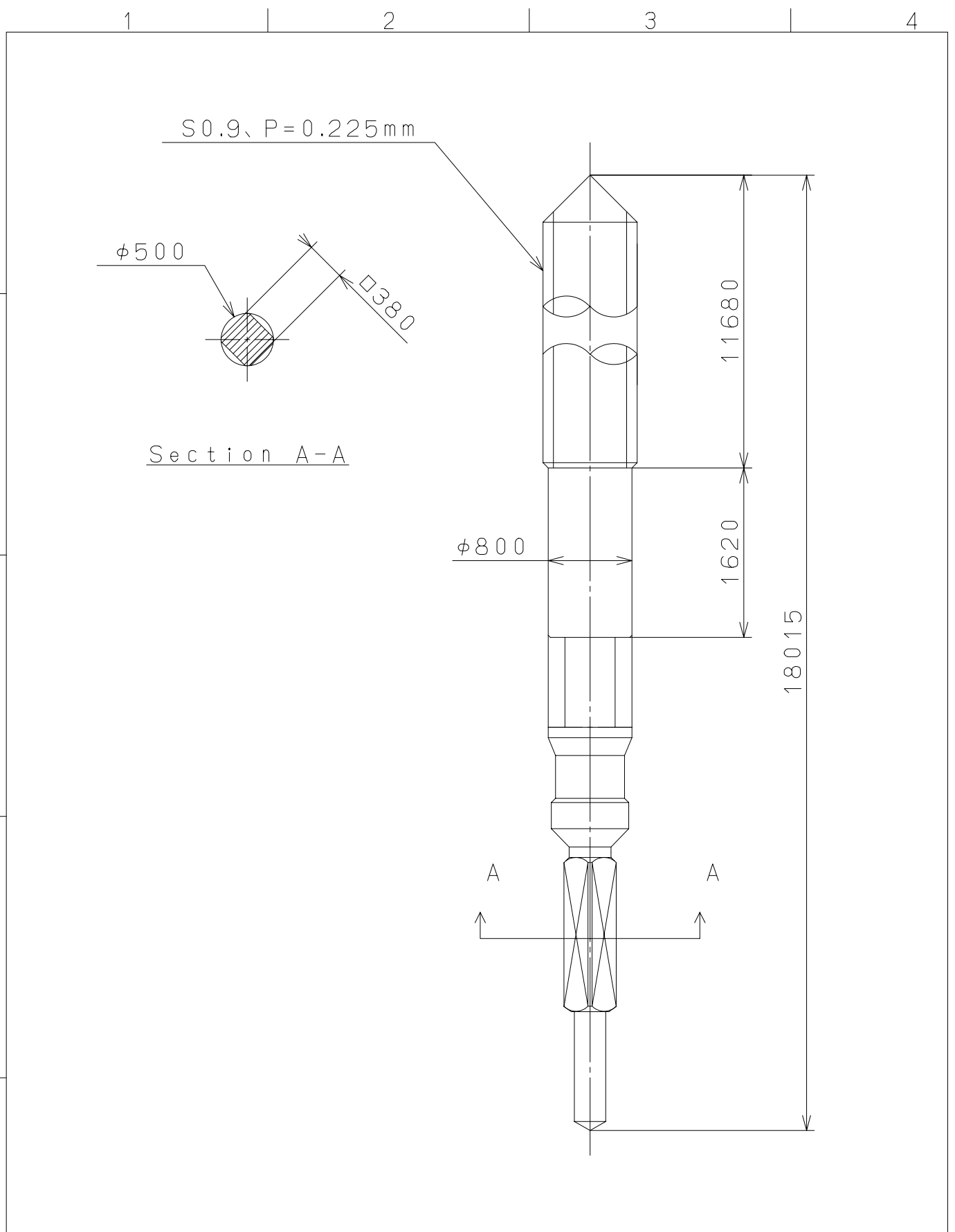

△5			Quantity		Cal.NO.:
△4			Unit	1 / 1000 mm	
△3			Scale	20 / 1	Parts No.:
△2			Date		065-505
△1			Drawn		
Mark	Date	Description	Appr.	Checked	Name:
		Alterations		Approved	SETTING STEM
Material					Drawing No.: 5050S000
Heat Treatment				General Tolerances	<b>MIYOTA</b>
Hardness				Dimensions	
Plating				Angles	
					CITIZEN WATCH CO., LTD. TOKYO, JAPAN