

This drawing is provisional and subject to our reconfirmation and/or revision without notice.

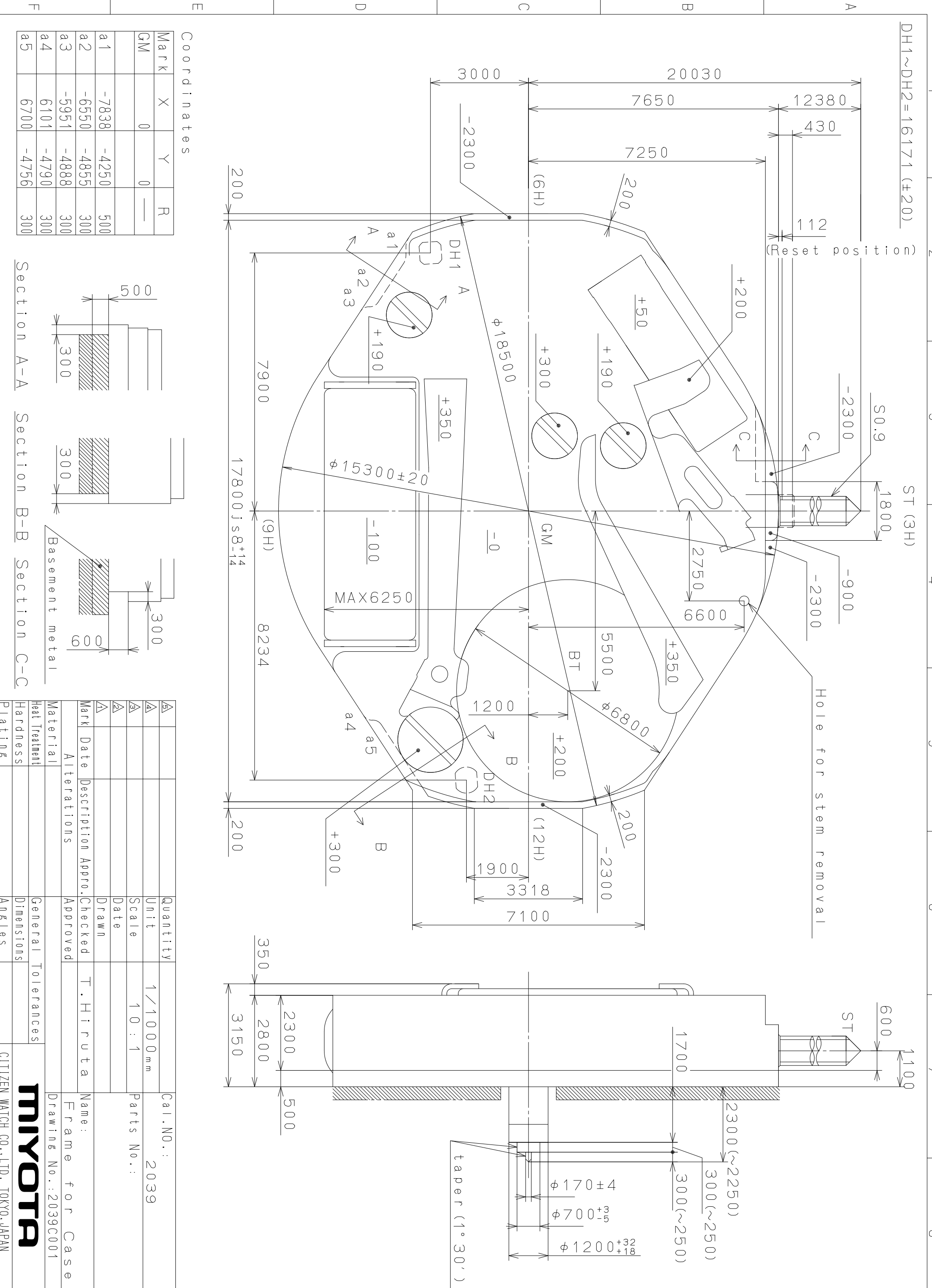

Coordinates

Mark	X	Y	R
GM	0	0	—
a1	-7838	-4250	500
a2	-6550	-4855	300
a3	-5951	-4888	300
a4	6101	-4790	300
a5	6700	-4756	300

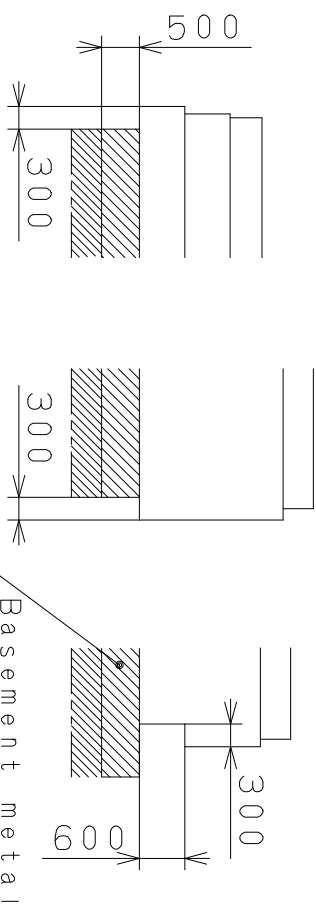

Mark	Date	Description	Appr.	Checked	Drawn	Quantity	Unit	Scale	Parts No.:
△5						1	1/1000 mm	10:1	2039
△4									
△3									
△2									
△1									
Material	Alterations		Approved	Name:		Frame for Case			
Heat Treatment				T. Hiruta		Drawing No.: 2039C001			
Hardness						CITIZEN WATCH CO., LTD. TOKYO, JAPAN			
Plating									

This drawing is provisional and subject to our reconfirmation and/or revision without notice.

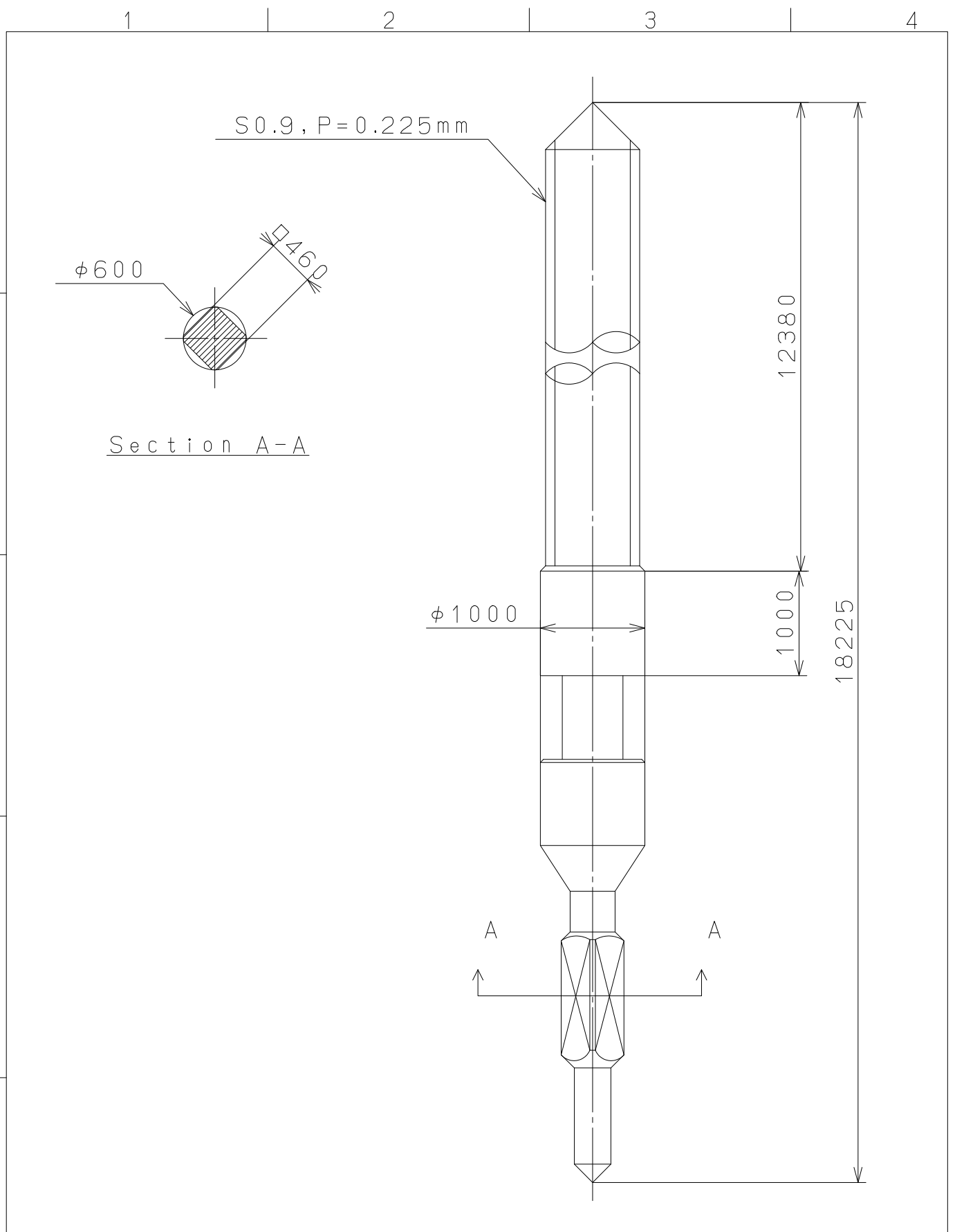

⑤			Quantity		Cal.NO.:
④			Unit	1 / 1000 mm	
③			Scale	20 : 1	Parts No.:
②			Date		065-468
①			Drawn		
Mark	Date	Description	Appro.	Checked M. Kobayashi	Name:
Alterations			Approved		SETTING STEM
Material					Drawing No.: 4680S001
Heat Treatment	General Tolerances				MIYOTA
Hardness	Dimensions				
Plating	Angles				
					CITIZEN WATCH CO., LTD. TOKYO, JAPAN