

This drawing is provisional and subject to our reconfirmation and/or revision without notice.

DH7~DH8=24390±20
DH9~DH10=24493±20

Coordinates		
Mark	X	Y
GM	0	0
DH7	9207	8080
DH8	-7522	-9668
DH9	-7193	9800
DH10	6848	-10269

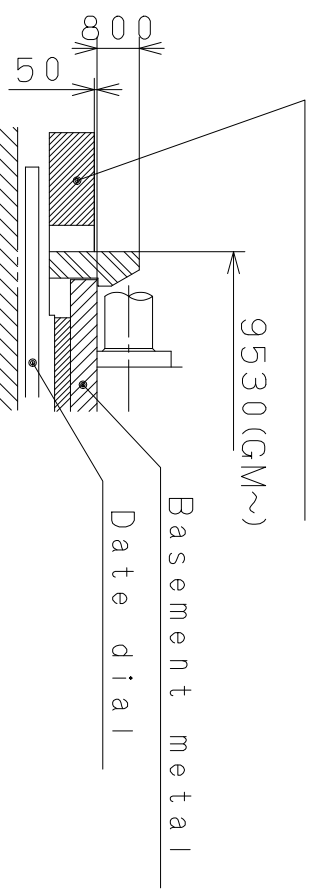
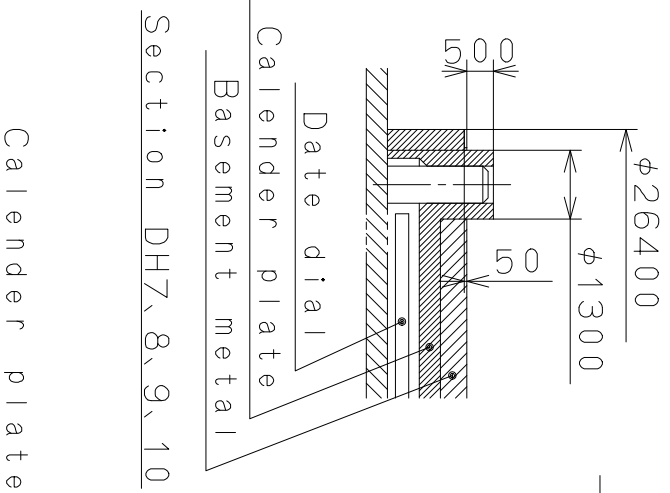
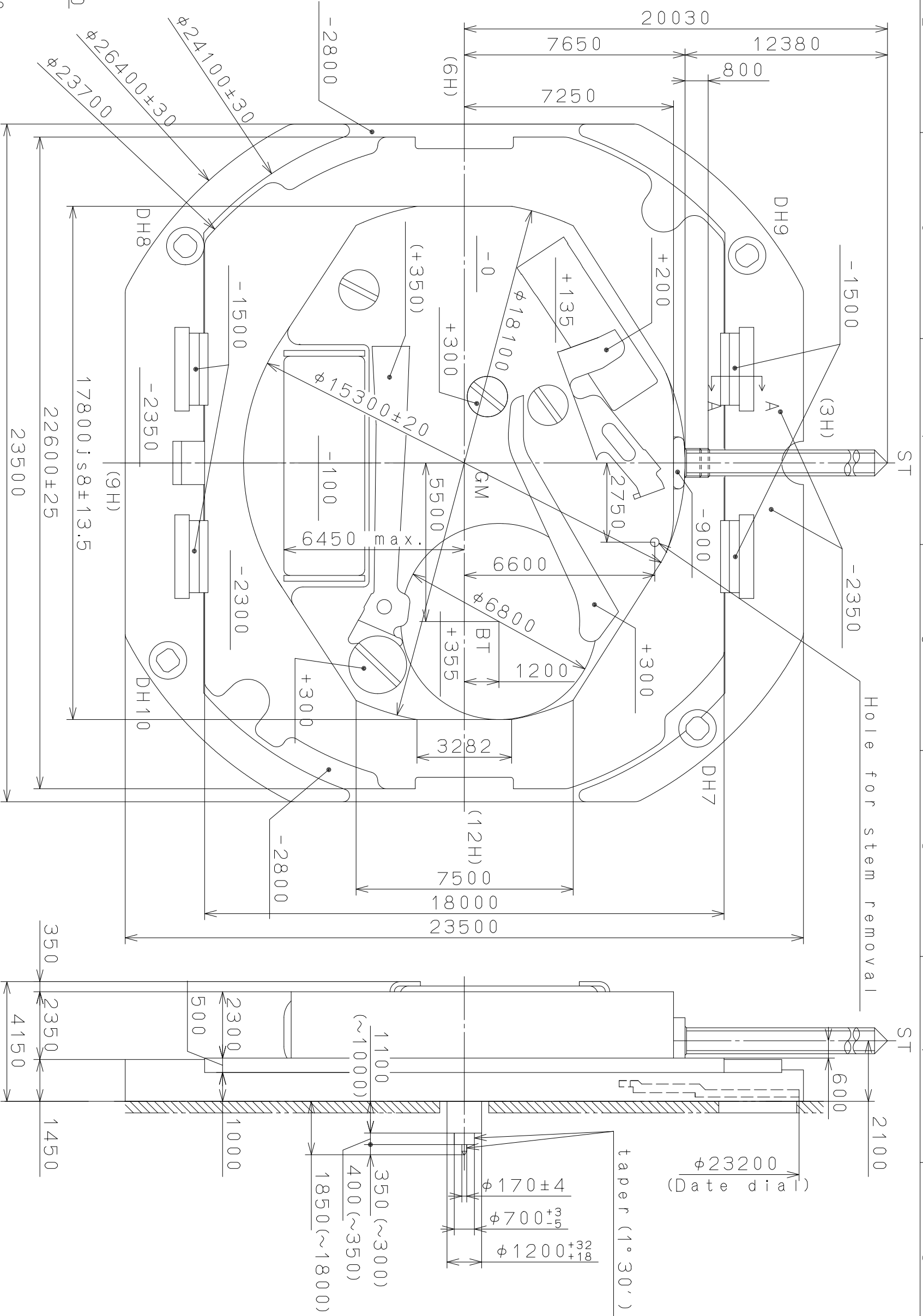

Mark	Date	Description	Appro.	Checked	Drawn	Quantity	Unit	Cal. NO.:
△						1	1/1000 mm	2315
△							Scale	7 : 1
△							Date	
△							Drawn	
△							Checked	
△							Approved	
Alterations						Name: D. Yamada		
Material						Frame for Case		
Heat Treatment						Drawing No.: 231500C0		
Hardness						Parts No.:		
Plating						CITIZEN WATCH CO., LTD. TOKYO, JAPAN		

Miyota
CITIZEN WATCH CO., LTD. TOKYO, JAPAN

This drawing is provisional and subject to our reconfirmation and/or revision without notice.

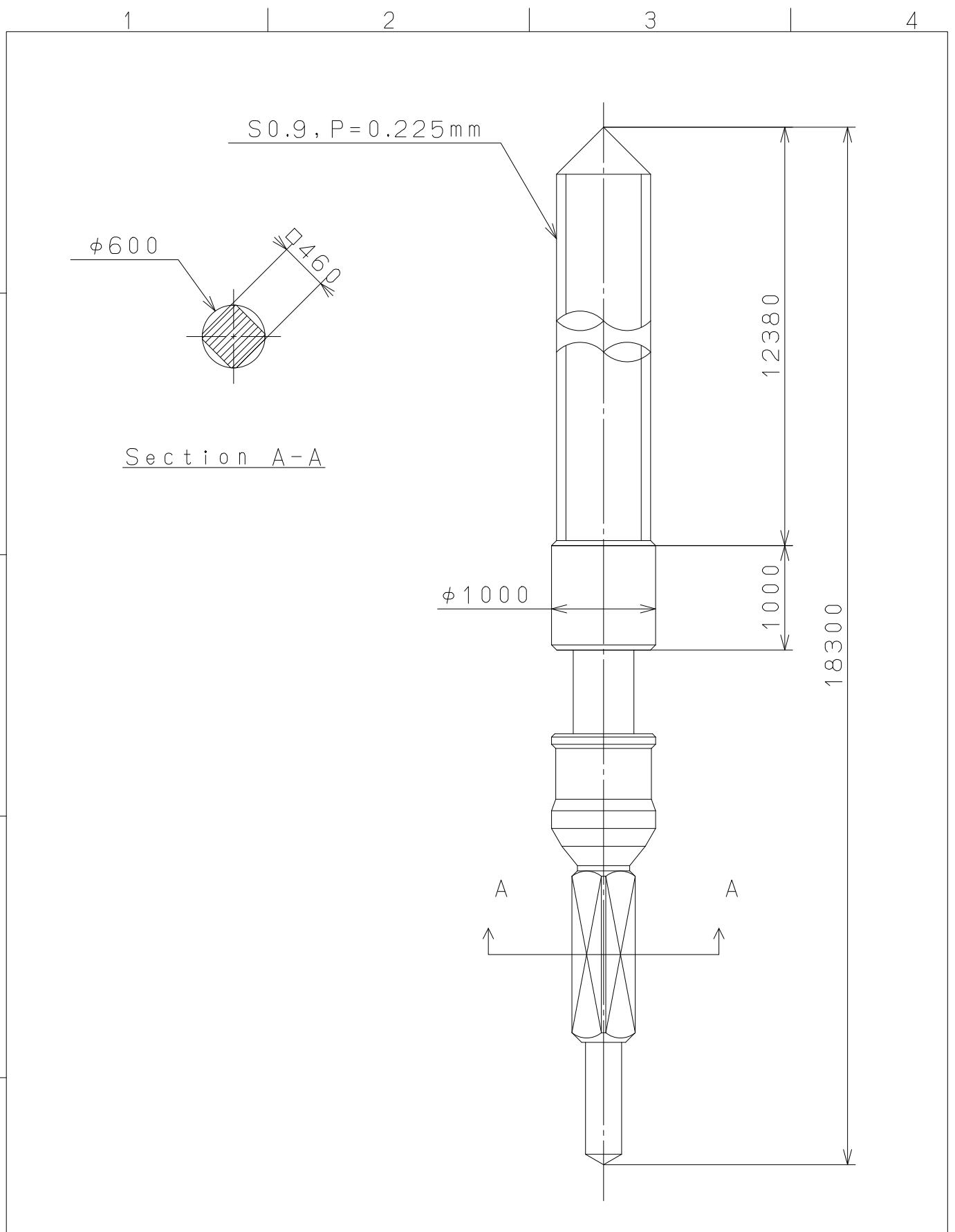

△5			Quantity		Cal.NO.:
△4			Unit	1 / 1000 mm	
△3			Scale	20 : 1	Parts No.:
△2			Date		065-299
△1			Drawn		
Mark	Date	Description	Appr.	Checked	D. Yamada
Alterations			Approved	Name:	
					SETTING STEM
Material					Drawing No.: 299000S0
Heat Treatment					MIYOTA CITIZEN WATCH CO., LTD. TOKYO, JAPAN
Hardness	General Tolerances				
Plating	Dimensions				
	Angles				