

This drawing is provisional and subject to our reconfirmation and/or revision without notice.

xxx T1PW 6P27 (01) xxx (2100 1121 ) 00-07-19

DH5~DH6=22287 (±20)

Coordinates			
Mark	X	Y	R
GM	0	0	—
DH5	-8759	6900	—
DH6	8251	-7500	—
a1	2351	11100	200
a2	7235	9131	200
a3	10800	3490	500
a4	10800	-3490	500
a5	3490	-10800	500
a6	-2700	-11100	200
a7	-5389	-10216	300
a8	-10800	-3490	500
a9	-10800	3490	500
a10	-3490	10800	500
b1	9581	6360	150
b2	7928	8331	150
b3	-5773	9946	150
b4	-7839	8415	150
b5	-9572	-6374	150
b6	-7916	-8342	150
b7	9196	-6906	150
b8	10501	-4690	150

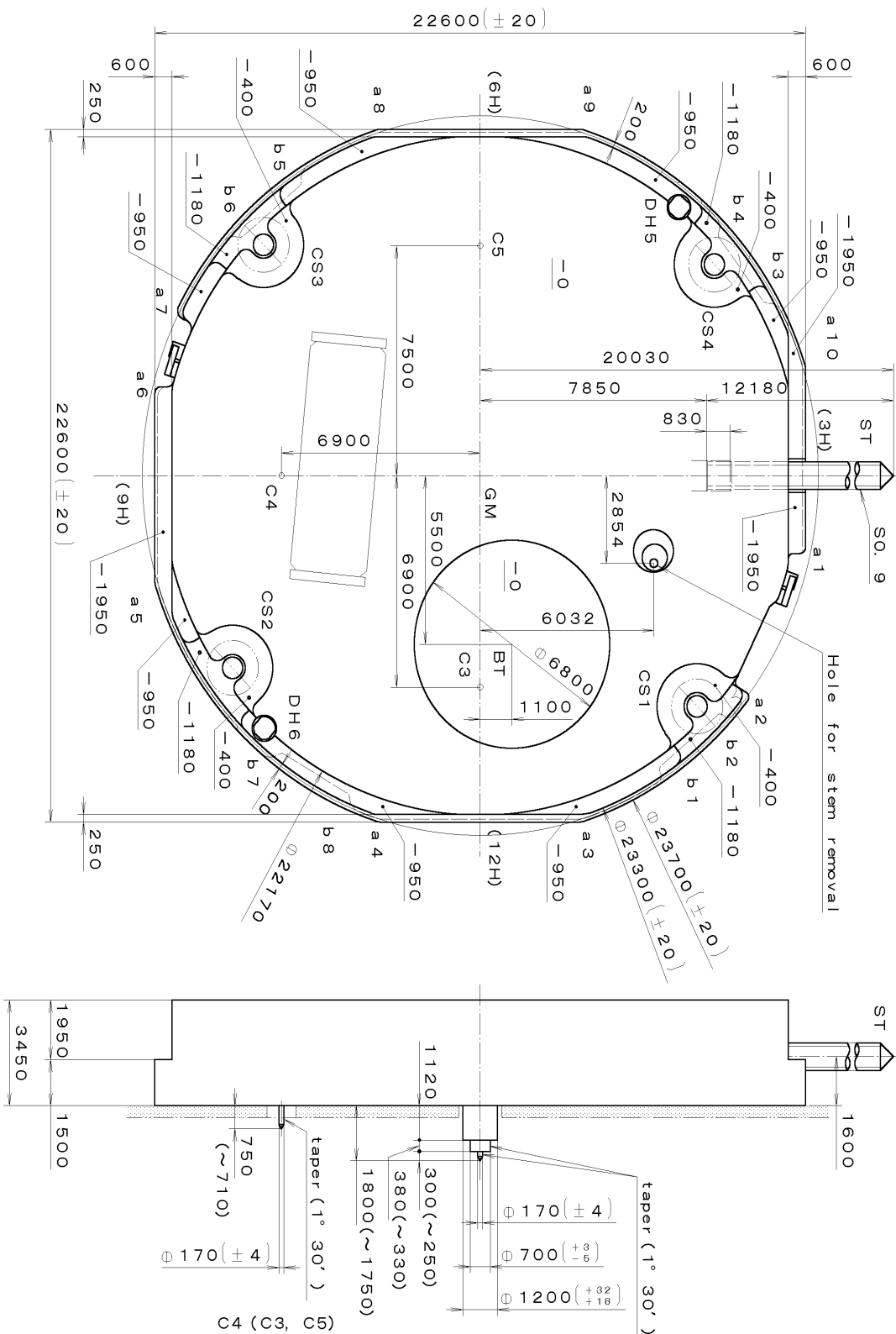

	H
With Battery strap	3600
Without Battery strap	3450

Quantity	Unit	Scale	Cal. No. :
1	1/1000 mm	7:1	6P27
Parts:			
Name: T. Hiruta			
Drawing No.: 6P27C0000			
Frame for Case			
Drawing No.: 6P27C0000			

Material	Heat Treatment	Hardness	Plating
General Tolerances			
Dimensions			
Angles			

MIYOTA

This drawing is provisional and subject to our reconfirmation and/or revision without notice.

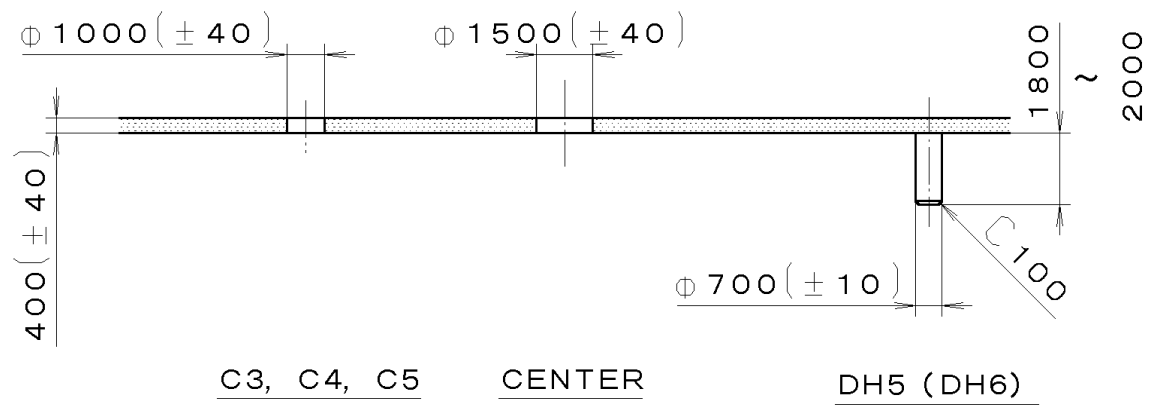
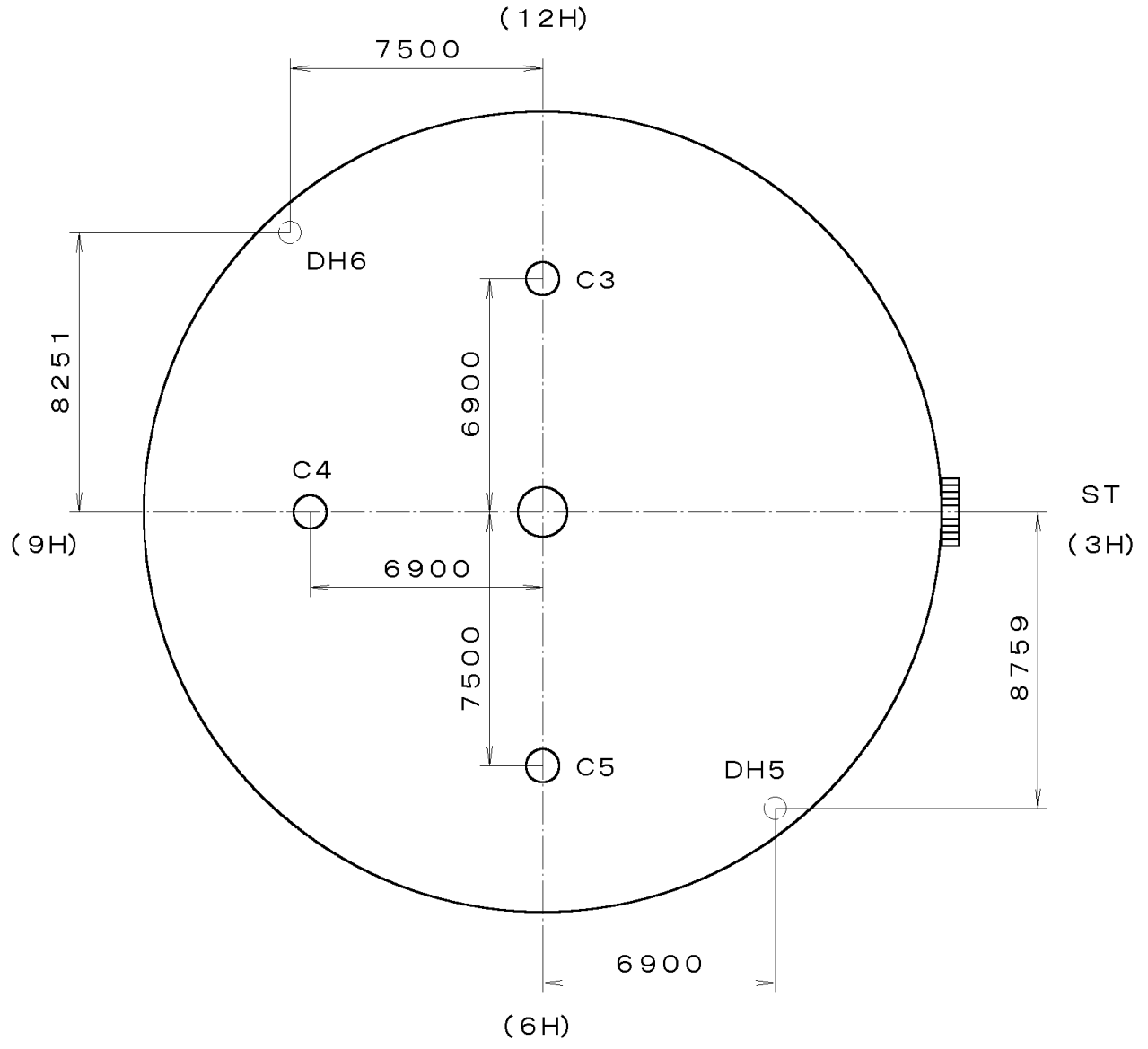

(00-07-25) (2100 1121) (01) \*\*\* 6P27-00A \*\*\* TIPW

7		Quantity		Cal. No. :	6P27-00A
6		Unit	1/1000 mm	Parts:	
5		Scale	5:1	Name:	Indications for Dial
4		Date		Drawing No. :	6P27D000
3		Drawn			
2		Checked	T. Hiruta		
1		Approved			
<b>Material</b>					
Heat Treatment		General Tolerances		<b>MIYOTA</b>	
Hardness		Dimensions			
Plating		Angles			

2010/05/12 (17:15:34)

This drawing is provisional and subject to our reconfirmation and/or revision without notice.

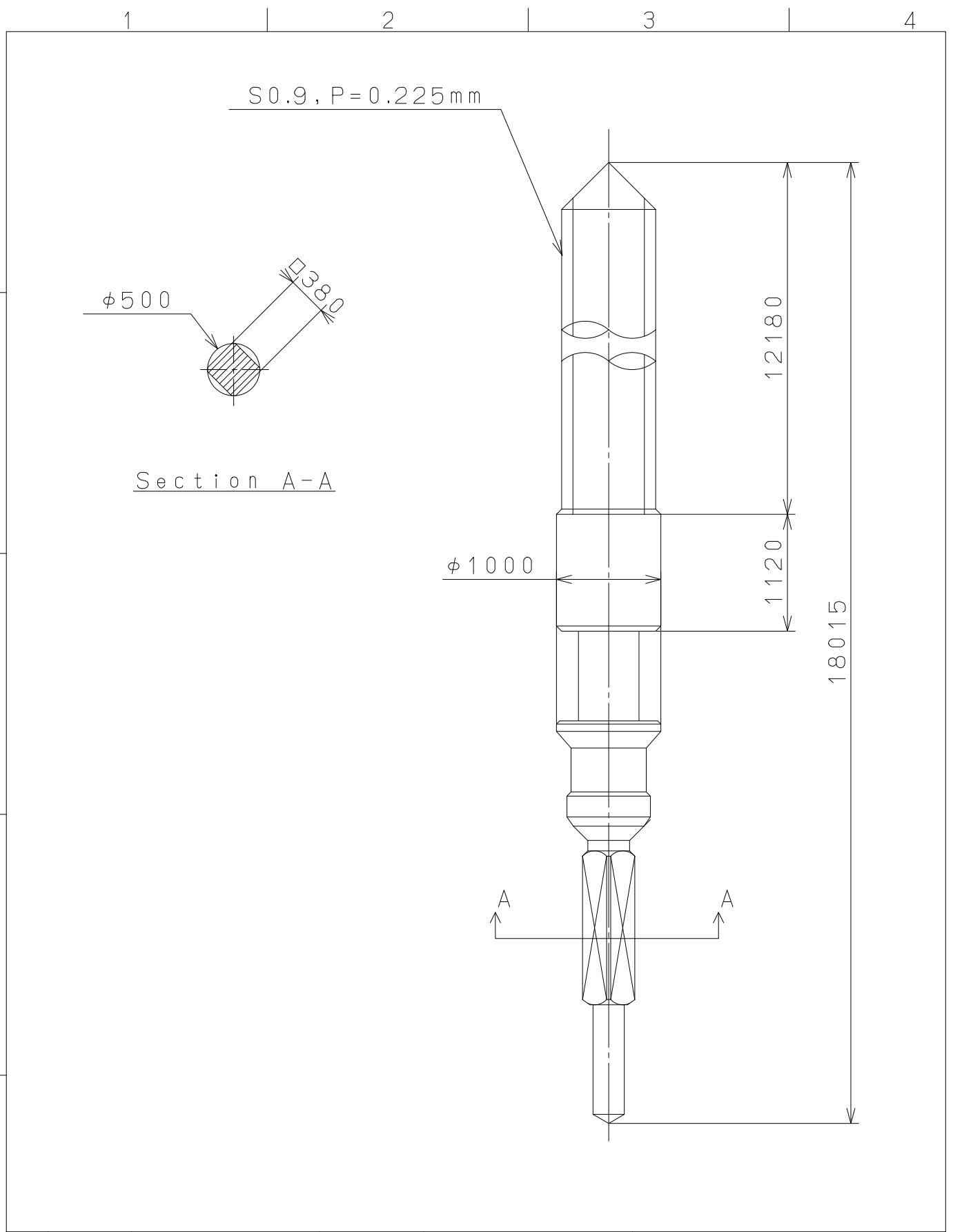

⑤			Quantity		Cal.NO.:
④			Unit	1/1000mm	
③			Scale	20:1	Parts No.:
②			Date		065-379
①			Drawn		
Mark	Date	Description	Appro.	Checked	T.Hiruta
Alterations			Approved	Name:	
			SETTING STEM		
Material				Drawing No.:3790S000	
Heat Treatment				<b>MIYOTA</b> CITIZEN WATCH CO.,LTD. TOKYO,JAPAN	
Hardness					
Plating					